

Strobe, 21 Joules, Explosion Proof XB4



Description:

These high output (21 Joule) strobes have been designed for use in potentially explosive atmospheres and harsh environmental conditions. The marine grade alloy or stainless steel enclosures are suitable for use offshore or onshore, where light weight combined with corrosion resistance and strength is required. Units can be painted to customer specification and fitted with identification labels.

Features*:

- UL Listed for USA and Canada
 - Hazardous locations:
 - Class I, Div 1, Groups C & D
 - Class I, Zone 1, AExd IIB T4
 - Ordinary locations: Visual-Signal Device
- ATEX approved
- Certified temperature -67°F to $+158^{\circ}\text{F}$ (-55°C to $+70^{\circ}\text{C}$)
- NEMA 4x & 6, IP67 and IP66
- Various lens colors
- Twin replaceable tubes
- Tapered spigot flamepath.
- 4 wire monitored connection
- Optional lens guard
- 24 VDC
- 110 & 240 VAC
- Xenon

*Depending on version.

Architects and Engineers Specifications

Explosion-proof strobes shall be UL and cUL Listed for Class I, Division 1, Groups C&D, and Class I, Zone 1, AExd IIB T4 hazardous locations and shall be listed under UL Standard 1638 for Indoor/Outdoor use. The strobes shall be constructed of marine grade alloy with an epoxy paint finish and shall meet NEMA 4x, NEMA6, IP 66 and IP 67 environmental requirements over a temperature range of -67°F to 158°F (-55°C to 70°C) in hazardous and harsh environments.

The strobe shall be rated to flash at 1 Hz with 21 joules per flash. Rated current draw shall not exceed 1400 mA at 24 vdc. The strobe shall be capable of direct surface mounting in any direction.

Note: Due to continuous development of our products, specifications and offerings are subject to change without notice in accordance with Cooper Wheelock standard terms and conditions.

Specification

Voltage	DC		AC 50/60 Hz	
	24	110	240	254
Tube Energy (Joules)	21	21	21	21
Peak Current Consumption (mA)	1400	350	185	210
Effective Intensity (Cd)	355	355	355	355

FOR COLORED LENSES

Color	Red	Blue	Amber	Green	Yellow
Multiplying Factor (Approximate)	0.15	0.12	0.51	0.49	0.86

Certification: **UL Listed for USA and Canada**
 – Hazardous locations:
 Class I, Div 1 Groups C-D
 Class I, Zone 1
 AExd 11B T4
 Listing No. E187894.
 – Ordinary locations: Visual-Signal Device.
 Listing No. S8128.
ATEX approved: EExd IIC T5
Cert. No. Baseffa 02ATEX0224X

Certified Temperature:
 –67°F to +158°F (–55°C to +70°C)

Ingress Protection: NEMA 4x & 6, IP66 & 67

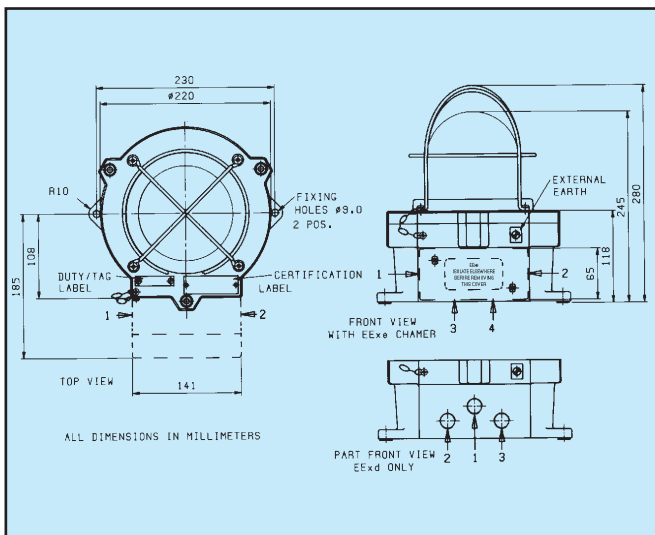

Terminals:	8 off suitable for up to 10 AWG conductor size
Entries:	Up to 3 x 1/2" or 3/4" NPT
Materials:	LM25TF Marine Grade Alloy body. Grade 316 ANC4B Stainless Steel body. Toughened Wellglass.
Weights:	LM25: 14.5lb./6.6kg. Stainless Steel: Add 18.5lb./8.5kg.
Finish:	Red epoxy paint finish as standard or to customer's specification.

Configuration Options:

The following code is designed to help in the selection of the correct unit. Build up the reference number by inserting the code for each component into the appropriate box.

Type	Certification	Voltage	Terminals	Cable Entries	Flash Rate	Other Options	Lens Guard	Lens Color	Tag/Duty Label	Material	Finish																																														
XB4			8D																																																						
<table border="1"> <thead> <tr> <th>Voltage</th> <th>Code</th> </tr> </thead> <tbody> <tr> <td>24VDC</td> <td>B</td> </tr> <tr> <td>110VAC</td> <td>E</td> </tr> <tr> <td>240VAC</td> <td>H</td> </tr> </tbody> </table>		Voltage	Code	24VDC	B	110VAC	E	240VAC	H	<table border="1"> <thead> <tr> <th>Entries</th> <th>Code</th> </tr> </thead> <tbody> <tr> <td>1/2" NPT</td> <td>*D</td> </tr> <tr> <td>3/4" NPT</td> <td>*E</td> </tr> </tbody> </table> <p>*prefix entry size (see diagram above) with entry position code e.g. 1D2D.</p>		Entries	Code	1/2" NPT	*D	3/4" NPT	*E	<table border="1"> <thead> <tr> <th>Options</th> <th>Code</th> </tr> </thead> <tbody> <tr> <td>None</td> <td>A</td> </tr> <tr> <td>Yes*</td> <td>Y</td> </tr> </tbody> </table> <p>*Please specify</p>		Options	Code	None	A	Yes*	Y	<table border="1"> <thead> <tr> <th>Color</th> <th>Code</th> </tr> </thead> <tbody> <tr> <td>Red</td> <td>R</td> </tr> <tr> <td>Blue</td> <td>B</td> </tr> <tr> <td>Green</td> <td>G</td> </tr> <tr> <td>Yellow</td> <td>Y</td> </tr> <tr> <td>Amber</td> <td>A</td> </tr> <tr> <td>Clear</td> <td>C</td> </tr> </tbody> </table>		Color	Code	Red	R	Blue	B	Green	G	Yellow	Y	Amber	A	Clear	C	<table border="1"> <thead> <tr> <th>Finish</th> <th>Code</th> </tr> </thead> <tbody> <tr> <td>Red</td> <td>R</td> </tr> <tr> <td>Blue</td> <td>B</td> </tr> <tr> <td>Yellow</td> <td>Y</td> </tr> <tr> <td>Grey</td> <td>G</td> </tr> <tr> <td>White</td> <td>W</td> </tr> <tr> <td>Other – specify</td> <td>S</td> </tr> </tbody> </table>		Finish	Code	Red	R	Blue	B	Yellow	Y	Grey	G	White	W	Other – specify	S
Voltage	Code																																																								
24VDC	B																																																								
110VAC	E																																																								
240VAC	H																																																								
Entries	Code																																																								
1/2" NPT	*D																																																								
3/4" NPT	*E																																																								
Options	Code																																																								
None	A																																																								
Yes*	Y																																																								
Color	Code																																																								
Red	R																																																								
Blue	B																																																								
Green	G																																																								
Yellow	Y																																																								
Amber	A																																																								
Clear	C																																																								
Finish	Code																																																								
Red	R																																																								
Blue	B																																																								
Yellow	Y																																																								
Grey	G																																																								
White	W																																																								
Other – specify	S																																																								
<table border="1"> <thead> <tr> <th>Certification</th> <th>Code</th> </tr> </thead> <tbody> <tr> <td>UL</td> <td>UL</td> </tr> <tr> <td>UL (ordinary locations)</td> <td>UW</td> </tr> </tbody> </table>		Certification	Code	UL	UL	UL (ordinary locations)	UW	<table border="1"> <thead> <tr> <th>Flash Rate</th> <th>Code</th> </tr> </thead> <tbody> <tr> <td>60/min.</td> <td>06</td> </tr> <tr> <td>120/min.</td> <td>12</td> </tr> <tr> <td>240/min.</td> <td>24</td> </tr> </tbody> </table>		Flash Rate	Code	60/min.	06	120/min.	12	240/min.	24	<table border="1"> <thead> <tr> <th>Lens Guard</th> <th>Code</th> </tr> </thead> <tbody> <tr> <td>None</td> <td>N</td> </tr> <tr> <td>Yes</td> <td>Y</td> </tr> </tbody> </table>		Lens Guard	Code	None	N	Yes	Y	<table border="1"> <thead> <tr> <th>Duty Label</th> <th>Code</th> </tr> </thead> <tbody> <tr> <td>None</td> <td>N</td> </tr> <tr> <td>Yes*</td> <td>Y</td> </tr> </tbody> </table> <p>*(Please specify)</p>		Duty Label	Code	None	N	Yes*	Y	<table border="1"> <thead> <tr> <th>Material</th> <th>Code</th> </tr> </thead> <tbody> <tr> <td>Stainless steel</td> <td>0</td> </tr> <tr> <td>Alloy</td> <td>1</td> </tr> </tbody> </table>		Material	Code	Stainless steel	0	Alloy	1																
Certification	Code																																																								
UL	UL																																																								
UL (ordinary locations)	UW																																																								
Flash Rate	Code																																																								
60/min.	06																																																								
120/min.	12																																																								
240/min.	24																																																								
Lens Guard	Code																																																								
None	N																																																								
Yes	Y																																																								
Duty Label	Code																																																								
None	N																																																								
Yes*	Y																																																								
Material	Code																																																								
Stainless steel	0																																																								
Alloy	1																																																								
		<table border="1"> <thead> <tr> <th>Terminals & Type</th> <th>Code</th> </tr> </thead> <tbody> <tr> <td>8 x 10 AWG</td> <td>8D</td> </tr> </tbody> </table>		Terminals & Type	Code	8 x 10 AWG	8D																																																		
Terminals & Type	Code																																																								
8 x 10 AWG	8D																																																								

Note: When placing your order, please include Supervision Diode on products.



WE ENCOURAGE AND SUPPORT NICET CERTIFICATION
 3 YEAR WARRANTY

XB4 08/11

NJ Location
 273 Branchport Ave.
 Long Branch, NJ 07740
 P: 800-631-2148
 F: 732-222-8707
 www.coopernotification.com