

INSTALLATION INSTRUCTIONS
120VAC MULTITONE APPLIANCES MT4-115

Use this product according to this instruction manual. Please keep this instruction manual for future reference.

GENERAL

MT4-115 Multitone Appliances are UL-Listed under Standard 464 for Fire Protective Signaling Service. They are listed for both indoor and outdoor use with the backboxes specified in these instructions (see Mounting Options). MT4-115 Multitone Appliances can be field set to produce any one of eight commonly used alarm tones. Sound output can be field set to provide either HIGH (HI) dBA or STANDARD (STD) dBA sound output level. All inputs have DC blocking capacitor for compatibility with supervision when used with a Fire Alarm Control Panel (FACP).

WARNING: Please read these instructions carefully before using this product. The MT4-115 Multitone Appliance must be field set to the desired dBA sound output level and alarm tone before they are installed. This is done by properly adjusting a four-position switch in accordance with these instructions. Incorrect settings will result in improper performance and could result in property damage and serious injury or death to you and/or others.

CAUTION: Not recommended for use at refrigerator/freezer door entrances or other areas with persistent condensation.

SPECIFICATIONS

Table 1: UL Listed Models and Ratings

Model	Regulated Voltage (V _{RMS})	Voltage Range (V _{RMS})
MT4-115	120	96-132

Table 1A: dBA and Current Ratings for Multitone Appliances

Tone	Maximum RMS Current (AMPS)		dBA Reverberant at 10 Feet Per UL 464	
	HI	STD	HI	STD
Horn	0.050	0.042	88	82
Bell	0.041	0.039	82	75
March Time Horn	0.050	0.040	85	79
Code-3 Horn	0.050	0.042	85	75
Code-3 Tone	0.042	0.040	79	75
Slow Whoop	0.050	0.042	88	82
Siren	0.045	0.041	85	82
HI/LO	0.042	0.039	82	79

WARNING: For UL Applications these appliances were tested to the operating voltage limits of 96-132 volts. Do not apply 80% and 110% of these voltage values for system operation.

This model is UL-Listed for indoor/outdoor use with a temperature range of -40°F to +150°F (-40°C to +66°C) and maximum humidity of 98% RH.

WARNING: Ensure the total RMS current required by all appliances that are connected to the system's primary and secondary power sources do not exceed the power sources' rated capacity or the current ratings of any fuses on the circuits to which these appliances are wired. Overloading power sources or exceeding fuse ratings could result in loss of power and failure to alert occupants during an emergency, which could result in property damage and serious injury or death to you and/or others.

When calculating the total currents: Use Table 1 to determine the highest value of RMS Current for an individual audible (across the expected operating voltage range of the audible), then multiply these values by the total number of audibles; be sure to add the currents for any other appliances, including audible signaling appliances, powered by the same source and include any required safety factors.

WARNING: Ensure all fuses used on signaling circuits are rated to handle the maximum inrush or peak current from all appliances on those circuits. Failure to do this may result in loss of power to the signaling circuit and the failure of all appliances on that circuit to operate, which could result in property damage and serious injury or death to you and/or others.

The Multitone Audible Appliances produce a brief inrush current that lasts for just 50 microseconds but can reach a peak value of 5.0 Amps.

WARNING: If MT4-115 Multitone Appliances are operated within 15 inches of a person's ear, they can produce a sound pressure level that exceeds the maximum 120 dBA permitted by ADA and OSHA rules. Exposure to such sound levels can result in damage to a person's hearing.

SETTINGS

The Switch (SW1) of the Multitone Appliance, shown in Figure 1, is used to set the desired dBA sound output level and alarm tone. The factory settings are shown below. Read these instructions carefully before changing any of these factory settings.

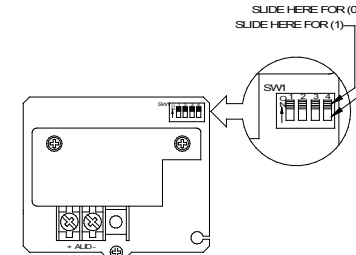

Figure 1: PC Board Layout Showing Location of Switch (SW1)

The factory settings are: HIGH dBA SW1 POS 1 set on 1 HORN TONE SW1 POS 2, 3, 4 set on 1, 1, 1.

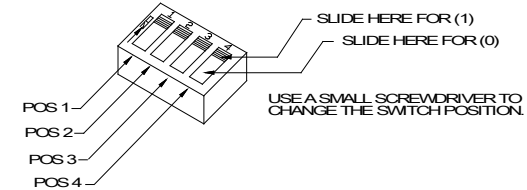

Figure 2: Switch (SW1) Settings

STEP 1: Set desired dBA sound output level as follows (refer to Figure 2 and Table 2).

Table 2: dBA Sound Output Level Settings

Decibel Level (dBA)	SW1 Switch Settings (POS 1)
High dBA	1 (Factory Setting)
Standard dBA	0

STEP 2: Set desired alarm tone as follows (refer to Figure 2 and Table 3).

MT4-115 Multitone Appliances are field set for any one of eight alarm tones by setting a four-position switch (SW1) as shown in Figure 2 and Table 3. Use SW1 POS 2, 3, 4 to select the desired alarm tone (refer to Table 3 below).

Table 3: Alarm Tones				
Tone	Pattern Description	SWI		
		Switch Settings		
		POS	POS	POS
Horn	Broadband Horn (Continuous) (Factory Setting)	1	1	1
Bell	1560 Hz Modulated (0.07 Sec. ON/Repeat)	1	0	1
March Time Horn	Horn (0.25 Sec. ON/0.25 Sec. OFF/Repeat)	0	0	1
Code-3 Horn	Horn (ANSI S3.41 Temporal Pattern)	1	1	0
Code-3 Tone	500 Hz (ANSI S3.41 Temporal Pattern)	0	1	1
Slow Whoop	500-1200 Hz Sweep (4.0 Sec. ON/0.5 Sec. OFF/Repeat)	0	1	0
Siren	600-1200 Hz Sweep (1.0 Sec. ON/Repeat)	1	0	0
HI/LO	1000/800 Hz (0.25 Sec. ON/Alternate)	0	0	0

NOTE: The Code-3 Horn and Code-3 Tone (set on HIGH dBA) incorporate the temporal pattern specified by ANSI/NFPA for standard emergency evacuation signaling. ***They should be used only for fire evacuation signaling and not for any other purpose.***

The Horn and Bell Tones can be used on coded systems with a minimum On-Time of 1/4 of a second. All other tones are recommended for use only on continuous (non-coded) systems.

WIRING INFORMATION

WARNING: Shut off all power before starting the installation. Electric shock can cause death or serious injury.

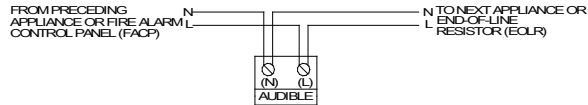

Figure 3: Wiring Diagram

- Strip leads 3/8 of an inch and connect to screw terminals. MT4-115 Multitone Appliances have in-out wiring terminals that accept two #12 to #18 American Wire Gauge (AWG) wires at each screw terminal.
- Break all in-out wire runs on supervised circuits to ensure integrity of circuit supervision. The polarity shown in the wiring diagram is for operation of the appliances. The polarity is reversed by the FACP during supervision.

MOUNTING OPTIONS

CAUTION: The following figures show the maximum number of field wires (conductors) that can enter the backbox used with each mounting option. If these limits are exceeded, there may be insufficient space in the backbox to accommodate the field wires and stresses from the wires could damage the product.

Although the limits shown for each mounting option comply with the National Electrical Code (NEC), Cooper Notification recommends use of the largest backbox option shown and the use of approved stranded field wires, whenever possible, to provide additional wiring room for easy installation and minimum stress on the product from wiring.

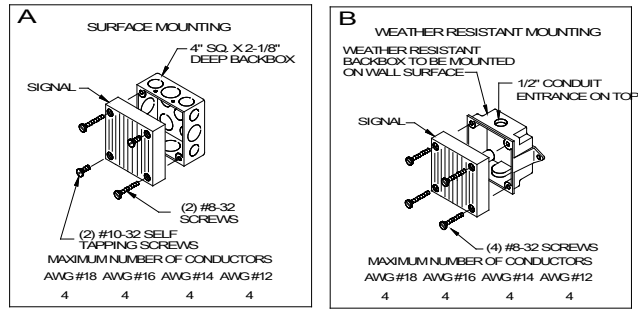

APPLICATION NOTES

CAUTION: If sheathed multiconductor cable or 3/4-inch conduit fittings are used, verify the installed product has sufficient clearance and wiring room prior to installing backboxes and conduit.

- For weather resistant installation, use outdoor mounting option. Outdoor backbox must be mounted vertically with "TOP" as marked to allow any moisture or condensation to drain properly through drain holes on bottom of backbox.
- MT4-115 Multitone Appliances can be surface mounted to a standard 4-inch square by 2-1/8 inches deep electrical box (Figure A) or a weather resistant backbox (WBB) (Figure B).
- Select largest backbox shown in Mounting Options where possible, to provide additional wiring room for easy installation.
- Conduit entrance to backboxes should be selected to ensure sufficient wiring clearance for installed equipment. When extension rings are required, conduit should enter through backbox, not extension ring. Use Steel City #53151/1-1/2 inches deep or #53171/2-1/8 inches deep extension rings or equal with same area cut out in back.
- Use care and proper techniques to position the field wires in the backbox so they use minimum space and produce minimum stress on the product. This is especially important for stiff, heavy-gauge wires with thick insulation or sheathing.
- Do not pass additional wires (used for other than signaling appliances) through the backbox. Such additional wires could result in insufficient wiring space for the signaling appliance.
- The Code-3 Horn and Code-3 Tone incorporate the temporal pattern specified by ANSI/NFPA/ISO for standard emergency evacuation signaling. They should be used only for fire evacuation signaling and not for any other purpose.
- The Horn and Bell Tones can be used on coded systems with a minimum On-Time of 1/4 of a second. All other tones are recommended for use only on continuous (non-coded) systems.

The Multitone products and these instructions are copyrighted by Cooper Notification and contain proprietary, confidential and trade secrets of Cooper Notification. No part of the Multitone products and these instructions may be photocopied, printed or reproduced in any form or modified, adapted, changed or enhanced, or converted to another programming language, or used to create updated, related or derivative works, without the prior written consent of Cooper Notification. No part of the Multitone shall be decompiled, disassembled or reverse engineered.

NOTE: This equipment has been tested and found to comply with the limits for a Class A digital device, pursuant to part 15 of the FCC Rules. These limits are designed to provide reasonable protection against harmful interference when the equipment is operated in a commercial environment. This equipment generates, uses, and can radiate radio frequency energy and, if not installed and used in accordance with the instruction manual, may cause harmful interference to radio communications. Operation of this equipment in a residential area is likely to cause harmful interference in which case the user will be required to correct the interference at his own expense.

ANY MATERIAL EXTRAPOLATED FROM THIS DOCUMENT OR FROM COOPER NOTIFICATION MANUALS OR OTHER DOCUMENTS DESCRIBING THE PRODUCT FOR USE IN PROMOTIONAL OR ADVERTISING CLAIMS, OR FOR ANY OTHER USE, INCLUDING DESCRIPTION OF THE PRODUCT'S APPLICATION, OPERATION, INSTALLATION AND TESTING IS USED AT THE SOLE RISK OF THE USER AND COOPER NOTIFICATION WILL NOT HAVE ANY LIABILITY FOR SUCH USE.

01/13