

HALO



Sustainable **LED** Design™

Stasis LED

Architectural Track Lighting System

COOPER Lighting

Stasis LED

Cooper Lighting is proud to expand our popular Stasis family once again to truly position it as an industry-leading track solution. The Stasis LED product platform now incorporates high output and wall wash luminaires, offering the flexibility of four different LED fixture options – large high output, large wall wash, medium and small.

The sustainability of the Stasis LED luminaire family dramatically reduces the maintenance and service costs over traditional sources. Light emitting diodes (LED) are solid state devices that do not have filaments or glass components that can break, causing the source to fail. Over 70% of the initial light output is maintained after 50,000 hours of operation. LED technology is perfect for almost all applications given there is limited infrared, low heat and no ultraviolet emissions.



HALO

Energy Savings

Environmental and legislative awareness continues to drive demand for energy-efficient lighting solutions. LED luminaires are high-efficiency alternatives to more traditional light sources, such as halogen, fluorescent and ceramic metal halide (CMH). Simply changing one fixture to Stasis LED saves hundreds of dollars over the life of the fixture.

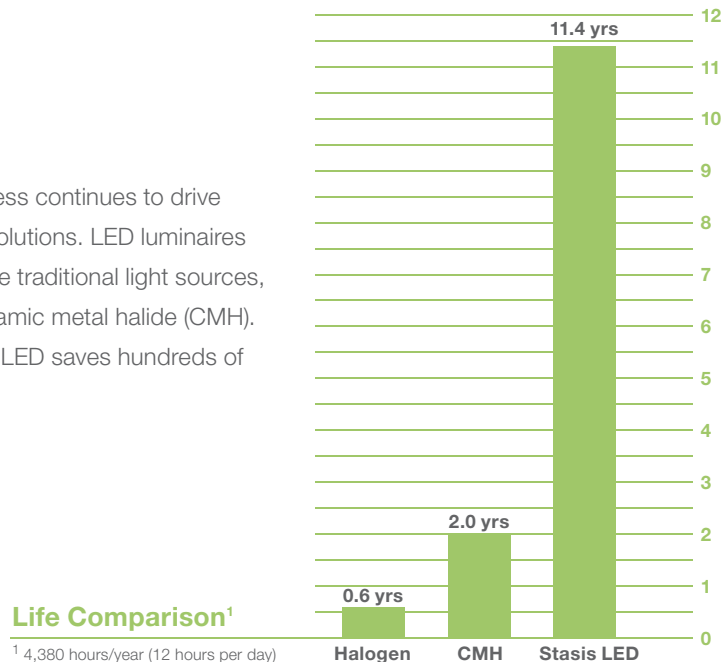



A Optical Package

- Patented optical design
- Field changeable for added flexibility
- Multiple beam distributions to meet all application needs
- Two-piece design yields exceptional cut-off
- Fixture accommodates one piece of media
- No color separation or blue rings around the beam

B LED Technology

- Incomparable color consistency and tight binning of $\pm 50^{\circ}\text{K}$ in color temperature
- High 85 CRI

C Thermal Management

- Patent pending
- Die-cast aluminum body
- Excellent thermal management to yield 70% lumen maintenance after 50,000 hours of operation

D Key Advantages

- Lockable rotation and tilt
- Arm allows adjustment of $\pm 90^{\circ}$ for both rotation and tilt
- Luminaire arm employs graduation marks every 15° for precise, repeatable tilt aiming
- Vertically oriented driver housing stays aligned with track for a uniform look

Stasis LED Large

Stasis LED Large offers the high-intensity lighting often required for retail and grocery applications and can easily replace more traditional high-wattage CMH sources. The patented optical design yields clean patterns of light with optimal cut-off and minimized source brightness. A variety of optical packages and the ability to field change the distribution sets this luminaire apart from all other LED track fixtures. Clean lines and aesthetic design fit easily into all applications and become part of the design concept.



- Three finish options: white, black and aluminum haze
- Two color temperatures: 3000K and 4000K
- High 85 CRI
- Four field-changeable optical distributions:
 - Spot 15°
 - Narrow flood 25°
 - Flood 40°
 - Wall wash
- Wall wash luminaire is available in both 18W or 38W and ships with solite lens
- Easy installation yields simple retrofit opportunities with various connector options
- Superior light quality when compared to traditional light sources
- Five-year limited warranty

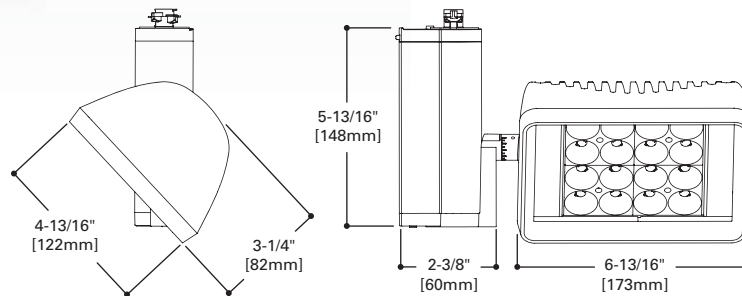

Ordering Information

Track L=Halo Power Track LA=Halo Architectural Track LF=Halo Architectural Flex Track LJ=Juno Track ¹ LL=Lightolier Track ² L2G=Global TEK or HTEK ³	805 Stasis LED 805 Size LRG=Large 38W	LRG Beam SP=Spot 15° NF=Narrow Flood 25° FL=Flood 40° WW=Wall Wash	CRI 8=85 CCT 30=3000K 40=4000K	Finish AH=Aluminum Haze P=White (L and LA only) MB=Black (L and LA only) Voltage Blank=120V 277=277V (only with LA and L2G)	HO =High Output (WW Beam only)	Accessories L850=Solite Lens Kit L8SP=15° Spot Optic Kit L8NF=25° Narrow Flood Optic Kit L8FL=37° Flood Optic Kit L8WW=Wall Wash Optic Kit
--	---	--	--	---	---------------------------------------	--

Notes

¹ Juno® T single circuit and 2 circuit track contact. Juno is a registered trademark of Juno Lighting.
² Lightolier® Lyfespan 6000 single circuit and 2 circuit track contact. Lightolier is a registered trademark of Philips Lighting.
³ Global® is a registered trademark of Nordic Aluminum.



HALO

Photometrics

High Output

CCT= 3000K

Spot: 15°
CBCP: 27,741
Lumens: 2399
LPW: 64.1

0° Aiming Angle
Horizontal Footcandles

D	FC	L	W
5.0	1110	2.0	2.0
7.5	493	3.0	3.0
10.0	277	4.0	4.0
12.5	178	5.0	5.0
15.0	123	5.9	5.9

30° Aiming Angle
Horizontal Footcandles

D	FC	L	W	CB
5.0	721	2.7	2.3	2.9
7.5	320	4.0	3.5	4.3
10.0	180	5.4	4.7	5.8
12.5	115	6.7	5.9	7.2
15.0	80	8.1	7.0	8.7

30° Aiming Angle
Vertical Footcandles on Wall

D	FC	L	W	CB
3.0	444	4.2	2.3	5.2
4.0	250	5.6	3.0	6.9
5.0	160	7.0	3.8	8.7
6.0	111	8.4	4.5	10.4

Narrow Flood: 25°
CBCP: 12,898
Lumens: 2383
LPW: 63.6

D	FC	L	W
5.0	516	3.0	3.0
7.5	229	4.5	4.5
10.0	129	5.9	5.9
12.5	83	7.4	7.4
15.0	57	8.9	8.9

D	FC	L	W	CB
5.0	343	3.9	3.5	2.9
7.5	152	5.8	5.2	4.3
10.0	86	7.7	6.9	5.8
12.5	55	9.7	8.7	7.2
15.0	38	11.6	10.4	8.7

D	FC	L	W	CB
3.0	244	5.4	3.2	5.2
4.0	137	7.2	4.2	6.9
5.0	88	9.0	5.3	8.7
6.0	61	10.8	6.3	10.4

Flood: 37°
CBCP: 5,669
Lumens: 2,319
LPW: 62.0

D	FC	L	W
5.0	227	4.7	4.7
7.5	101	7.1	7.1
10.0	57	9.4	9.5
12.5	36	11.8	11.9
15.0	25	14.1	14.2

D	FC	L	W	CB
5.0	163	5.5	5.3	2.9
7.5	72	8.3	7.9	4.3
10.0	41	11.1	10.6	5.8
12.5	26	13.9	13.2	7.2
15.0	18	16.6	15.9	8.7

D	FC	L	W	CB
3.0	139	5.9	4.6	5.2
4.0	78	7.9	6.1	6.9
5.0	50	9.8	7.6	8.7
6.0	35	11.8	9.2	10.4

Notes and Definitions

- Beam spread is to 50% center beam candlepower (CBCP).
- D= Distance in feet to floor or wall.
- FC= Footcandles on floor or wall at center beam aiming location.
- L= Effective Visual Beam length in feet (50% of maximum footcandle level)
- W= Effective Visual Beam width in feet (50% of maximum footcandle level)
- CB= Distance in feet across or down to center beam location

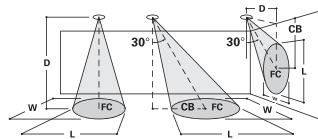

Wall Wash

High Output
Wall Wash
Lumens: 2,052
LPW: 55.5

Single Fixture 3' From Wall
Distance From Fixture Along Wall

DD	0	1	2	3	4	5
1	93	67	35	12	2	1
2	83	57	32	14	3	2
3	53	39	24	12	3	2
4	32	25	17	10	4	2
5	19	16	12	8	4	3
6	12	10	8	6	3	3
7	7	7	6	5	3	2
8	5	5	4	4	4	2
9	4	3	3	3	2	2
10	3	3	2	2	2	2

Multiple Fixtures 3' From Wall
Spacing Between Fixtures

DD	4	5	6						
1	100	72	100	95	42	95	94	23	94
2	93	65	93	87	44	87	85	28	85
3	64	49	64	57	36	57	55	25	55
4	43	36	43	37	28	37	34	21	34
5	29	26	29	24	21	24	22	17	22
6	21	19	21	17	15	17	15	13	15
7	15	14	15	12	12	12	11	10	11
8	11	11	11	9	9	9	8	8	8
9	9	9	9	7	7	7	6	6	6
10	7	7	7	6	6	6	5	5	5

Notes

- Illuminance values for multiple fixtures are based upon the center two units of a four unit array. Footcandle values are centerline of fixtures and centered between fixtures. 1 footcandle = 10.76 lux. 1 foot(") = 304.8mm.
- Illuminance values are cosine corrected initial value with no contribution from inter reflections from other room surfaces. Total illumination may increase from contributions from other surfaces.
- Changing fixture spacing will affect illuminance level.

$$\frac{\text{Existing Spacing}}{\text{New Spacing}} \times \text{Average Table Fc Level}$$
- 39W Multiplier = .5

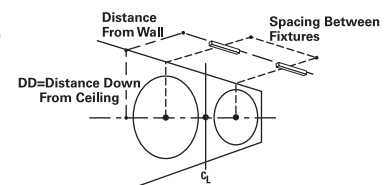

Stasis LED Small and Medium

The Stasis LED Small and Medium luminaire is perfect for those applications where performance is required from a discreet source. This fixture family can effortlessly replace traditional halogen and CMH light sources while yielding up to 85% energy and maintenance savings. Tight optical control provides superior light quality and precise aiming with minimal spill light. Stasis LED stands in a league all its own.

- Three finish options: white, black and aluminum haze
- Two color temperatures: 3000K and 4000K
- High 85 CRI
- Three optical distributions
 - Spot 8°
 - Narrow flood 25°
 - Flood 40°
- ELV dimmable to 15%
- Easy installation yields simple retrofit opportunities with various connector options
- Superior light quality when compared to traditional light sources
- Five-year limited warranty

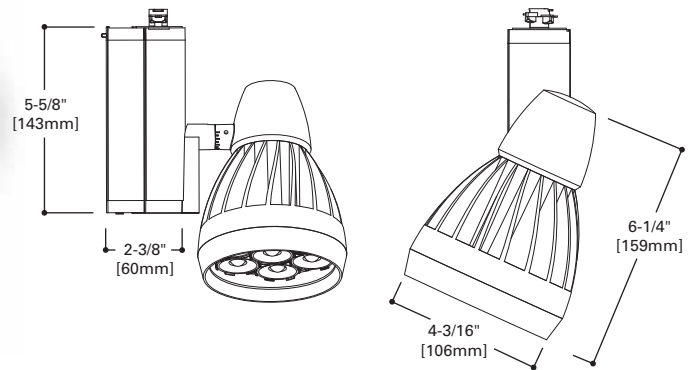
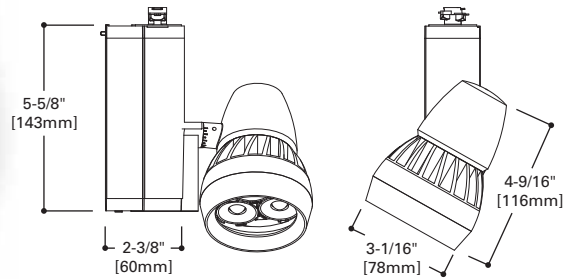

Ordering Information

<p>Track L=Halo Power Track LA=Halo Architectural Track LF=Halo Architectural Flex Track LJ=Juno Track ¹ LL=Lightolier Track ² L2G=Global TEK or HTEK ³</p>	<p>805 Stasis LED 805 Size SML=Small 8W MED=Medium 18W</p>	<p>Beam SP=Spot 8° NF=Narrow Flood 25° FL=Flood 40°</p>	<p>CRI 8=85 CCT 30=3000K 40=4000K</p>	<p>Finish AH=Aluminum Haze P=White (L and LA only) MB=Black (L and LA only) Voltage Blank=120V 277=277V (only with LA)</p>	<p>Accessories LM10530=Media Holder</p>
---	---	--	--	---	--

Notes

¹ Juno® T single circuit and 2 circuit track contact. Juno is a registered trademark of Juno Lighting.
² Lightolier® Lyfespan 6000 single circuit and 2 circuit track contact. Lightolier is a registered trademark of Philips Lighting.
³ Global® is a registered trademark of Nordic Aluminum.



HALO

Photometrics

Small

CCT= 3000K

0° Aiming Angle Horizontal Footcandles

Spot: 8°
CBCP: 14,618
Lumens: 330
LPW: 39

D	FC	L	W
5.0	585	0.6	0.6
7.5	260	0.9	0.9
10.0	146	1.2	1.2
12.5	94	1.5	1.5
15.0	65	1.8	1.8

Narrow Flood: 25°
CBCP: 1,168
Lumens: 311
LPW: 33

D	FC	L	W
5.0	47	2.4	2.4
7.5	21	3.7	3.7
10.0	12	4.9	4.9
12.5	7	6.1	6.1
15.0	5	7.3	7.3

Flood: 40°
CBCP: 636
Lumens: 295
LPW: 31

D	FC	L	W
5.0	25	3.5	3.5
7.5	11	5.2	5.2
10.0	6	7.0	7.0
12.5	4	8.7	8.7
15.0	3	10.5	10.5

Medium

Color Temp.= 3000K

0° Aiming Angle Horizontal Footcandles

Spot: 8°
CBCP: 36,079
Lumens: 774
LPW: 42

D	FC	L	W
5.0	1443	0.6	0.6
7.5	641	0.9	0.9
10.0	361	1.2	1.2
12.5	231	1.5	1.5
15.0	160	1.8	1.8

Narrow Flood: 25°
CBCP: 3,044
Lumens: 726
LPW: 41

D	FC	L	W
5.0	122	2.3	2.3
7.5	54	3.4	3.4
10.0	30	4.6	4.6
12.5	19	5.7	5.7
15.0	14	6.8	6.8

Flood: 40°
CBCP: 1,736
Lumens: 725
LPW: 38

D	FC	L	W
5.0	69	3.5	3.5
7.5	31	5.2	5.2
10.0	17	6.9	6.9
12.5	11	8.7	8.7
15.0	8	10.4	10.4

Notes and Definitions

Beam spread is to 50% center beam candlepower (CBCP).

D= Distance in feet to floor or wall.

FC= Footcandles on floor or wall at center beam aiming location.

L= Effective Visual Beam length in feet (50% of maximum footcandle level)

W= Effective Visual Beam width in feet (50% of maximum footcandle level)

CB= Distance in feet across or down to center beam location

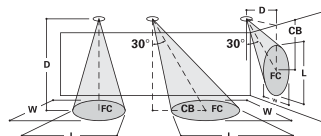

Track Systems

Miniature Track



Miniature track provides versatility for every lighting need.

Decorator finishes, push-in connectors and economy all combine to make single-circuit track perfect for residential or commercial use.

L650 2' Track Actual length: 20-1/8" (511mm).
Finishes: White (P), Black (MB), Silver (SL)

L651 4' Track Actual length: 44-1/8" (1121mm).
Finishes: White (P), Black (MB), Silver (SL)

L652 8' Track Actual length: 92-1/8" (2340mm).
Finishes: White (P), Black (MB), Silver (SL)

L653 12' Track Actual length: 140-1/8" (3559mm).
Finishes: White (P), Black (MB), Silver (SL)

Size

11/16" (17.5mm) deep by 1-3/8" (35mm) wide

Connectors

Connectors simply push into the track ends, eliminating splicing. Ls, Ts, Xs and the flexible connector allow track to be assembled in almost any pattern.

Specifications

Structural channel is extruded aluminum with 0.060" nominal wall thickness. Conductors are solid copper bus bars encased in rigid extruded PVC insulators. Polarized connectors and end caps are molded polycarbonate. Electrical capacity is 20 amps. UL/cUL listed.

Halo-2 Power-Trac



Halo-2 Power-Trac has two circuits for greater system flexibility.

Halo-2 Power-Trac system provides two separate 20 AMP circuits. Each circuit can be independently switched. Suitable for commercial, merchandising and residential applications.

L641 4' Track Actual length: 42-5/8" (1083mm).
Finish: White (P), Black (MB), Silver (SL)

L642 8' Track Actual length: 90-5/8" (2302mm).
Finish: White (P), Black (MB), Silver (SL)

L643 12' Track Actual length: 138-5/8" (3521mm).
Finish: White (P), Black (MB), Silver (SL)

Size

11/16" (17.5mm) deep by 1-3/8" (35mm) wide

Connectors

Connectors push easily into the track ends, eliminating splicing. Polarity arrows on connectors ensure proper installation. Just align arrows with polarity line on track and push in. Ls, Ts, Xs and flexible connector allow track to be assembled in almost any pattern.

Installation of Lampholders

Installing lampholders is simple with an adjustable contact that allows selection of the circuit position. Lift or lower the contact on the lampholder until it touches the plastic stop of the assembly. For circuit #1 move contact to the down position. For circuit #2 move contact to the up position.

Specifications

Structural channel is extruded aluminum with 0.060" nominal wall thickness. Conductors are solid copper bus bars encased in rigid extruded PVC insulators. Polarized connectors and end caps are molded polycarbonate. Electrical capacity is 20 amps per circuit when properly balanced. UL/cUL listed.

Halo Four Circuit Track



Four circuit track provides concise control of each circuit.

L621 4' Track Actual length: 42-7/8" (1089mm).
Finishes: White (P), Black (MB)

L622 8' Track Actual length: 90-7/8" (2308mm).
Finishes: White (P), Black (MB)

L623 12' Track Actual length: 138-7/8" (3527mm).
Finishes: White (P), Black (MB)

Four circuits give ample capacity for any lighting need, allowing greater load density (more watts per foot of track). The extra capacity can be used to make longer runs from a single feed point by spreading the load between the circuits. Additional circuits can be run through the integral raceway allowing even longer runs. Four Circuit Power-Trac offers greater flexibility. Four circuits can be individually switched to control more lighting functions. The L963 Converter is required for Halo Power-Trac lampholders to be used with Four Circuit Track.

L963 Single-Circuit to Four-Circuit Converter with Switch
Finishes: White (P), Black (MB)

IMPORTANT One L963 Converter is required for each lampholder used.

Size

1-3/4" (44mm) high and 1-3/4" (44mm) wide

Connectors

Connectors simply push into the track ends, eliminating splicing. Ls, Ts and Xs allow track to be assembled in almost any pattern.

Four Circuit Operations

Halo Four Circuit Track allows greater density by carrying up to 60 AMPS on 3-phase, 4-wire system or 40 AMPS on single-phase, 3-wire system. Fully polarized and grounded throughout. UL/cUL listed.

Lazer Track

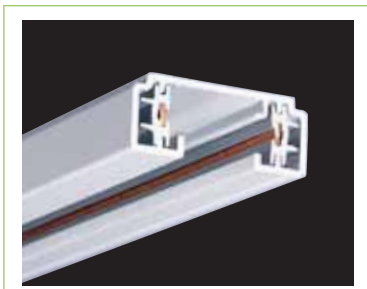

Lazer track offers economy and convenience.

LZR102 2' Track Actual length: 20-1/8" (511mm).
Finishes: White (P), Black (MB)

LZR104 4' Track Actual length: 44-1/8" (1121mm).
Finishes: White (P), Black (MB)

LZR106 6' Track Actual length: 68-1/8" (1730mm).
Finishes: White (P), Black (MB)

LZR108 8' Track Actual length: 92-1/8" (2340mm).
Finishes: White (P), Black (MB)

The Lazer Two-Conductor track is available in two finishes and 4 lengths. The overall height is only 9/16" with a decorative reveal at the ceiling line.

Size

9/16" (14mm) deep by 1-3/8" (35mm) wide

Connectors

Connectors push into the track ends. Straight, right angle and flexible connectors allow track to be assembled in almost any pattern.

Specifications

The structural channel is extruded aluminum with 0.050" nominal wall thickness. Conductors are solid copper buss bars encased in rigid extruded PVC insulators. Polarized connectors and end caps are molded polycarbonate. Electrical capacity is 20 AMPS. UL/cUL listed.

Halo Architectural Track

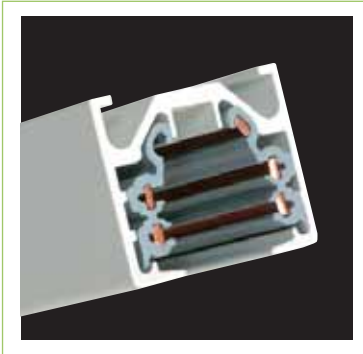

Architectural track provides a 120V or 277V option with two separate 40 AMP circuits and two neutrals.

LA631 4' Track Actual length: 42-7/32" (1072mm).
Finishes: White (P), Black (MB), Silver (SL)

LA632 8' Track Actual length: 88-7/32" (2240mm).
Finishes: White (P), Black (MB), Silver (SL)

LA633 12' Track Actual length: 136-7/32" (3460mm).
Finishes: White (P), Black (MB), Silver (SL)

Halo Architectural 120V or 277V Track System provides two separate 40 AMP circuits and two neutrals. Each circuit can be independently switched. Fully polarized and grounded throughout. Top portion of track is designed as a raceway for carrying up to 2 #8 AWG conductors. Raceway can be used to feed additional sections of track from the original feed point, minimizing installation time and cost. Halo Two Circuit Architectural Track accepts Halo 120V or 277V lampholders and is suitable for a wide range of commercial, merchandising and retail applications.

Size

1-7/16" (34mm) high and 1-13/16" (46mm) wide

Connectors

Connectors simply push into the track ends, eliminating splicing. Ls, Ts, Xs and the flexible connector allow track to be assembled in almost any pattern.

Specifications

Structural channel is extruded aluminum with 0.080" nominal wall thickness. Conductors are solid copper alloy bus bars with extruded polyvinyl insulators. Track maintains an independent positive ground path between lampholder, track channel and building's ground system.

Halo Flexible Track



Halo flexible track is the ultimate in aesthetic, mechanical and electrical versatility.

LF4AH 4' Track
Finishes: Aluminum Haze (AH)

LF4AH 8' Track
Finishes: Aluminum Haze (AH)

Halo Flexible Track is a three circuit, bendable track system. There are two 120V / 20A circuits with dedicated neutrals, as well as a third 12V / 25A circuit. The track can be used as either a stand-alone 120V or 12V system, or a combination of both. Each circuit can be independently switched. To change from one 120V circuit to the other, simply remove the lampholder and rotate adaptor 180° and reinstall. The system is suitable for a wide range of commercial, merchandising and residential applications. Its unique, fresh styling not only enhances, but can also trace virtually any interior design creation.

Size

1-1/2" (39mm) high and 7/16" (12mm) wide

Connectors

Numerous connectors and stem lengths make this system truly flexible to meet any design configuration.

Specifications

Structural channel is extruded aluminum I-beam 0.060" nominal wall thickness. Flexible Track has a minimum bend radius of 24 inches. 120V and 12V conductors are nickel-plated solid copper buss bars encased in extruded CPVC insulators. Grounding is accomplished through a grounding channel in the track. Track is asymmetric in nature and accepts connectors and lampholders in one direction only to maintain polarity. A track support is required every four feet and more supports may be required depending on the complexity of the curved design layout.

Consult factory for RSA Busway.

Connectors & Accessories

Description	Miniature Track	Halo-2 Power-Trac	Four Circuit Track	Lazer Track	Architectural Track
Outlet Box Cover	L900	L900	L900	-	L900
Live End Connector	L901	L941	L921	LZR200/LZR201	LA671
Straight Connector	L903	L943	L923	LZR203	LA673
Flexible Connector	L902	L942	-	LZR211	LA672
L Connector	L904	L943	L924	LZR203	LA674
T Connector	L905	L945R/L945L	L925	LZR213R/LZR213L	LA675
X Connector	L906	L946	L926	LZR214	LA676
Mini Joiner	L908	L949	-	LZR211	LA678
Floating Canopy and Connector	L909	L929	-	LZR202	-
Cord and Plug Connector	L950	-	-	LZR208	-
Conduit Connector	L979	L947	L982	LZR204/LZR205	LA670
T-Bar Attachment Clip	L983	L983	L983	LZR207	L983
Pendant Assembly	L992	L992	L954	L992	LA995

LED Breadth of Line

Indoor, Outdoor & Specialty Lighting Solutions

It's time to redefine expectations and embrace a new generation of outdoor and indoor luminaires that allow for meaningful energy reductions and improved maintenance cycles. Leading-edge solid-state components have been elegantly infused into a wide array of Cooper Lighting's product families to catapult LED into the mainstream by providing leading performance, energy, maintenance, and environmental benefits.



Ambient



Wall Mount



Decorative



Area / Site



Canopy

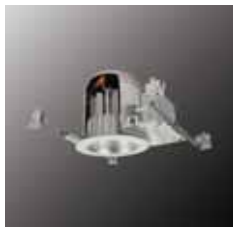

Recessed



Track



Specialty



Exit



Pathway



Landscape



Accent

LED Technology Supported by 175+ Years of Industry Expertise



The Innovation Center

Cooper's 60,000-square-foot Innovation Center opened its doors in 2009. The multi-million dollar facility is home to the research, development, design, validation, and manufacturing of proprietary LED and other advanced lighting technologies. Teams of highly skilled Mechanical, Electrical, Thermal, Optical, and Reliability Engineers work hand-in-hand with Industrial Designers, Lab Technicians, and Manufacturing personnel to accelerate the development and commercialization of relevant industry-leading LED solutions.



Design

Cooper has made significant investments in talented personnel, state-of-the-art equipment, and the latest analytical and design software. Our world-class Innovation Center teams execute multiple LED design and performance assessments, including visual renderings, thermal simulations, electrical analysis, and optical ray-tracing. Our stringent product development process ensures a highly reliable product every time.



Prototyping

The Research and Development Prototyping area houses world-class rapid prototype equipment and lean manufacturing workcell development capabilities to reliably deploy new advanced lighting technologies. The modernized rapid prototyping lab includes the latest milling and Computer Numeric Control (CNC) equipment and an advanced quality lab for layout and validation. In addition, operations such as painting, welding, and fused deposition modeling are performed.



Electrical & Optical Labs

Our highly qualified lab and research development teams take great pride in their active involvement in creating and driving industry standards. Cooper Lighting's Certified Test Laboratory conducts extensive testing of electrical, optical, and thermal properties for robustness in application and intended performance over rated life. The testing performed is capable of validating products to industry standards such as LM-79, LM-80, ENERGY-STAR® and UL.



Quality Testing & Assurance

Manufacturing and assembly is a critical and final step in the LED product development process. By involving the Innovation Center operations team throughout the design process, utilizing tools like Production Failure Modes and Effects Analysis (PFMEA), we have optimized our manufacturing process and mitigated risk of premature failure.

Our state-of-the-art Pilot Production area incorporates modular and transferable cell construction, a temperature and humidity controlled environment, and ESD protection for a well manufactured fixture each and every time.

Our products are further evaluated and qualified through 100% end-of-line testing for power (wattage), light output, and color temperature. Finally, our products are bar coded and the production data is captured in a manufacturing database to provide system and assembly level traceability and quality control.



Reliability & Thermal Testing

Reliability is one of the most important elements of LED lighting. Cooper's Reliability and Thermal Laboratory is vital to ensure our LED luminaires meet their stated performance over the lifetime of the product. Our experts use the most advanced environmental and thermal mapping test equipment along with a rigorous testing protocol and statistical analysis tools to ensure long-term performance of LED components, systems, and finished luminaires.

Cooper Lighting, LLC.

Customer First Center
1121 Highway 74 South
Peachtree City, GA 30269

P: 770-486-4800
F: 770-486-4801

www.cooperlighting.com

International Sales, USA

Cooper Lighting, LLC.
1121 Highway 74 South
Peachtree City, GA 30269
P: 770-486-4800
F: 770-486-4801

Canada

Cooper Lighting, LLC.
5925 McLaughlin Road
Mississauga, Ontario L5R 1B8
P: 905-507-4000
F: 905-568-7049

The Cooper Lighting Family

Halo
Metalux
Lumark
Sure-Lites
Neo-Ray
Corelite
Portfolio
Iris
Shaper
IO
Lumière
Invue
McGraw-Edison
Streetworks
Fail-Safe
PDS
MWS
RSA
Ametrix

Domestic Facilities

Cranbury, New Jersey
Elk Grove Village, Illinois
Irving, Texas
Ontario, California
Peachtree City, Georgia

Canadian Facility

Calgary, Alberta T2E 7V9
Mississauga, Ontario L5R 1B8



25% PCRf

Cooper Lighting, Halo, Halo-Power Trac and SustainablEDesign are valuable trademarks of Cooper Industries in the United States and other countries. You are not permitted to use the Cooper Trademarks without the prior written consent of Cooper Industries.

Cooper Industries plc
600 Travis, Ste. 5600
Houston, TX 77002-1001
P: 713-209-8400
www.cooperindustries.com