

ELEVATED STOP BAR LIGHT (FAA L-862S) INSTRUCTION SHEET

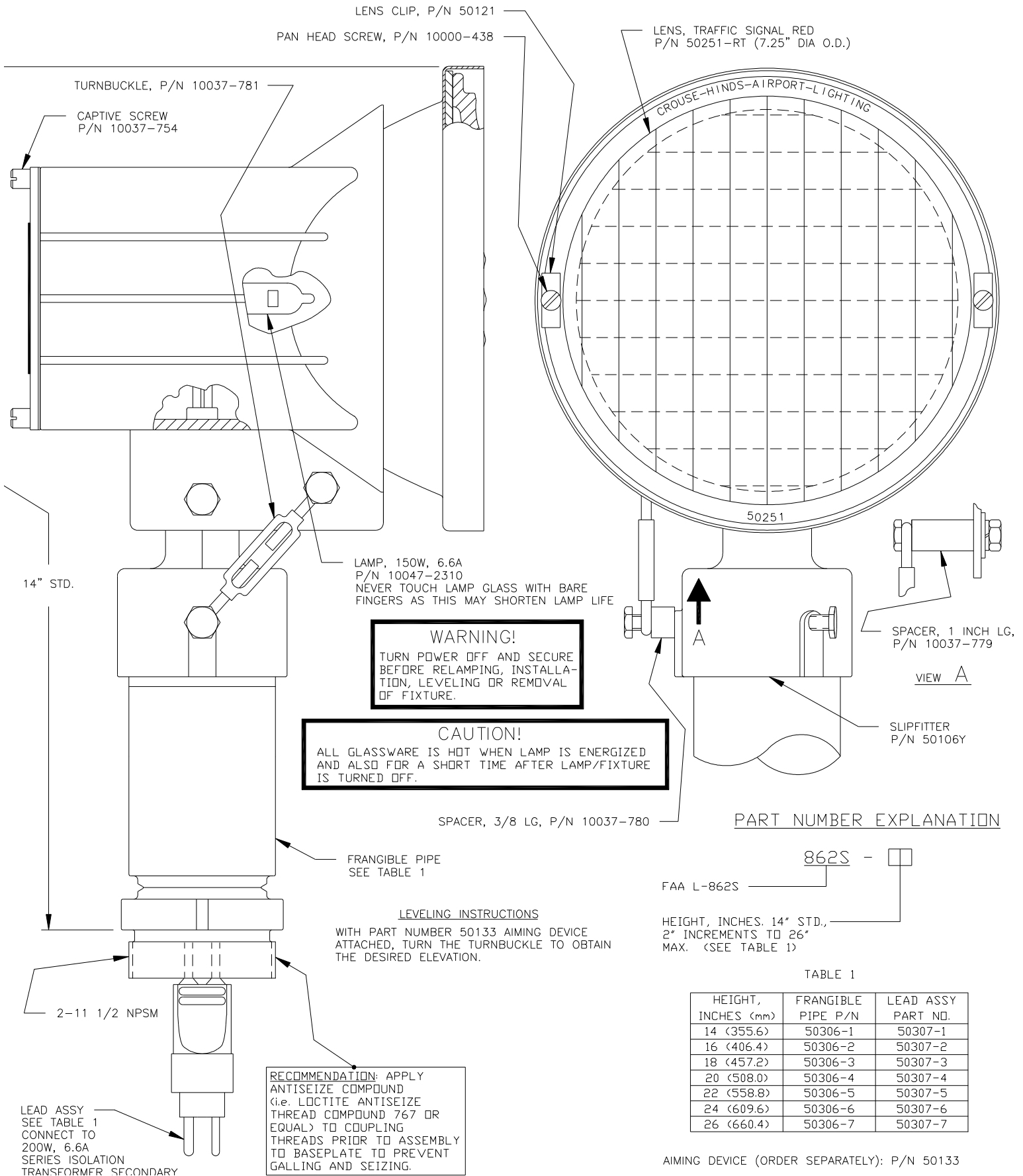

PART NUMBER EXPLANATION

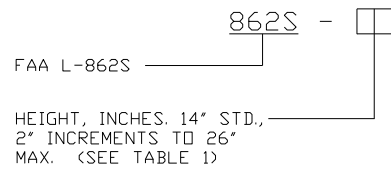

TABLE 1

HEIGHT, INCHES (mm)	FRANGIBLE PIPE P/N	LEAD ASSY PART NO.
14 (355.6)	50306-1	50307-1
16 (406.4)	50306-2	50307-2
18 (457.2)	50306-3	50307-3
20 (508.0)	50306-4	50307-4
22 (558.8)	50306-5	50307-5
24 (609.6)	50306-6	50307-6
26 (660.4)	50306-7	50307-7

AIMING DEVICE (ORDER SEPARATELY): P/N 50133

**INSTRUCTION SHEET
ELEVATED STOP BAR LIGHTS (FAA L-862S)**

LIMITED PRODUCT WARRANTY

THE FOLLOWING WARRANTY IS EXCLUSIVE AND IN LIEU OF ALL OTHER WARRANTIES, WHETHER EXPRESS, IMPLIED OR STATUTORY, INCLUDING, BUT NOT BY WAY OF LIMITATION, ANY WARRANTY OF MERCHANTABILITY OR FITNESS FOR ANY PARTICULAR PURPOSE.

Crouse-Hinds Airport Lighting Products warrants to each original Buyer of Products manufactured by the Company that such Products are, at the time of delivery to the Buyer, free of material and workmanship defects, provided that no warranty is made with respect to:

- (a) any Product which has been repaired or altered in such a way, in Company's judgment, as to affect the Product adversely;*
- (b) any Product which has, in Company's judgment, been subject to negligence, accident or improper storage;*
- (c) any Product which has not been operated and maintained in accordance with normal practice and in conformity with recommendations and published specification of Company; and,*
- (d) any Products, component parts or accessories manufactured by others but supplied by Company (any claims should be submitted directly to the manufacturer thereof).*

Crouse-Hinds Airport Lighting Product's obligation under this warranty is limited to use reasonable effects to repair or, at its option, replace, during normal business hours at any authorized service facility of Company, any Products which in its judgment proved not to be as warranted within the applicable warranty period. All costs of transportation of Products claimed not to be as warranted and of repaired or replacement Products to or from such service facility shall be borne by Purchaser. Company may require the return of any Product claimed not to be as warranted to one of its facilities as designed by Company, transportation prepaid by Purchaser, to establish a claim under this warranty. The cost of labor for installing a repaired or replacement product shall be borne by Purchaser. Replacement parts provided under the terms of this warranty are warranted for the remainder of the warranty period of the Products upon which they are installed to the same extent as if such parts were original components thereof. Warranty services provided under the Agreement do not assure uninterrupted operations of Products; Company does not assume any liability for damages caused by any delays involving warranty service. The warranty period for the Products is 24 months from date of shipment or 12 months from date of first use whichever occurs first.