

TOL

Taxiway Omnidirectional Light

Compliances:
 FAA AC 150/5345-46: L-852E
 ICAO Annex 14

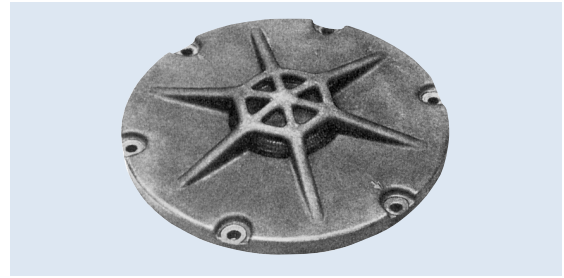
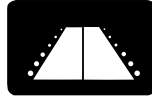

Features

- Variety of Mounting Methods
- Optional high-strength casting approximately double the tensile strength of ductile iron
- Optional metallic-ceramic coating for increased corrosion resistance

Ordering Information

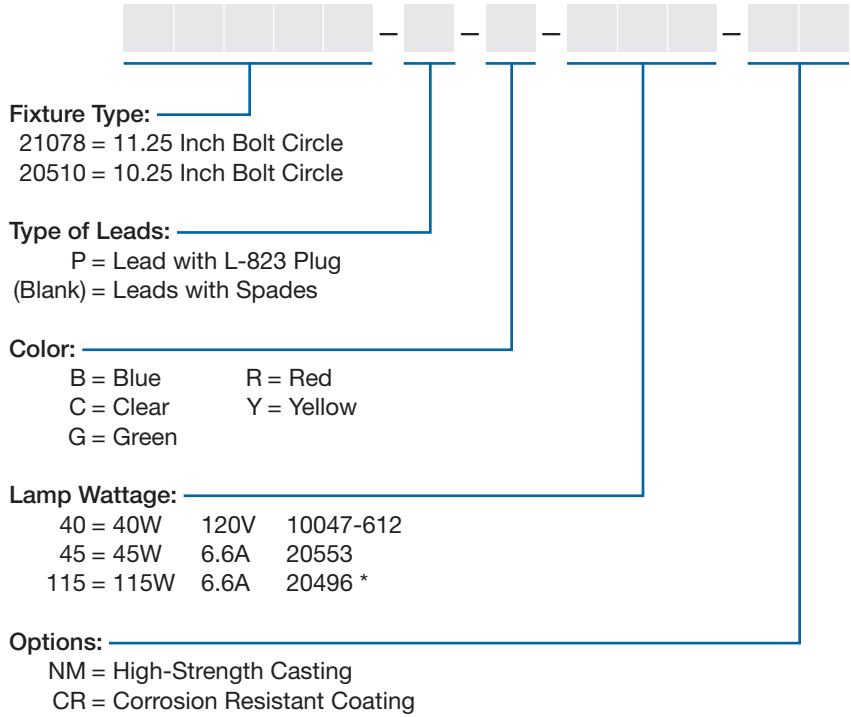

* 115W Lamp not applicable for fixtures with Blue and Green Lenses.

Outline Drawing

TOL: 21078

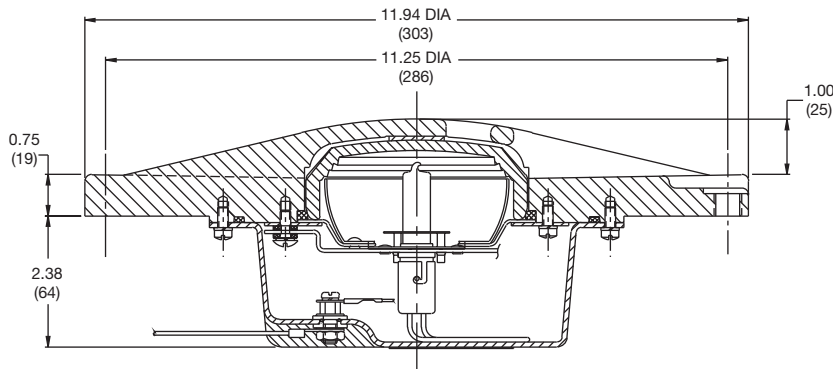

Six (6) bolt holes on an 11.25 inch diameter

Dimensions:	inches (mm)
Instruction Manual:	8352
Shipping Weight:	32 lbs. 14.5 kg.
Shipping Volume:	0.7 cu.ft. .02 cu.m.
Photometric Data:	Contact Field Services

Accessories

Catalog Number	Item Description	Shipping Weight		Shipping Volume	
		Lb.	Kg.	Cu.Ft.	Cu.M.
AC24242Q200303	Base L-868, Class I, 24" deep	63.0	28.6	2.5	.070
33004	Transformer 100W, 6.6/6.6A	12.0	5.4	0.4	.011
33001	Transformer 30/45W, 6.6/6.6A	8.0	3.6	0.2	.006
823KP-D4D4	Connector Kit L-823, 8 AWG, .32" to .43" O.D.				
10047-1425	Heat Shrink Kit 2 PC				

Note: Sectional bases may be required depending upon the paving technique.

Renewal Parts

Part Number	Description	Part Number	Description
20801	Socket Bracket Assembly	10035-33-345	O-Ring for Lens
19095-1	Socket Assembly (6.6A)	20512-1	Inner Cover Assembly w/ L823 Connector
20405	Socket Assembly (120V)	20512-2	Inner Cover Assembly w/ Spade Connector
19412-(color)	Lens	20400-2	O-Ring for Inner Cover
10047-612	Lamp 40W (120V)	20512-3	Inner Cover Assembly (120V) w/ L823
Connector			
20553	Lamp 45W (6.6A)	20512-4	Inner Cover Assembly (120V) w/ Spade
Connector			
20496	Lamp 115 (6.6A)		

