

PRO III™ TOL-LED

Omnidirectional Taxiway Edge Light

Compliances:

- FAA AC 150/5345-46: L-852T
- ICAO Annex 14
- UFC 3-535-01
- IEC 97/98A/DTS
- FAA Engineering Brief 67

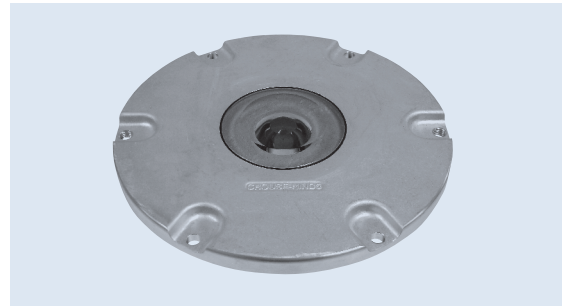

Applications

The TOL is an inset taxiway edge fixture. The TOL is intended for use on a 6.6A constant current circuit through an L-830/31 isolation transformer.

Features



- ETL Certified
- Low profile, <.25" (6 mm) – FAA Style 3
- High-strength aluminum optical assembly
- Easy to maintain – no sealant required for prism or feed-through assembly replacement
- Pressure test plug for seal integrity verification
- Long life LED
- Direct Replacement on existing circuit
- Complies with the intensity curve requirements for 3-step or 5-step circuits, 50/60 Hz.
- It is recommended that caution be used during snowplow operations. Use of a rubber tipped blade is recommended. Fixture is not warranted against snowplow damage.
- Non-Arctic Kit - Max fixture load 9.2W, 11.2VA, PF=.82, Isolation transformer required 10/15W
- Arctic Kit - Max fixture load 39.9W, 40.9VA, PF=.98, Isolation transformer required 30/45W

Ordering Information



Fixture Type: _____

Fixture Diameter: _____

- 008 = 8" Fixture with mounting bolt pattern per IEC specifications
- 12A = 12" Fixture with 11.25" mounting BC, L868 base can
- 12B = 12" Fixture with 10.25" mounting BC, L867 base can

Options: _____

- 1 = Arctic Kit

Outline Drawings

12" Fixture

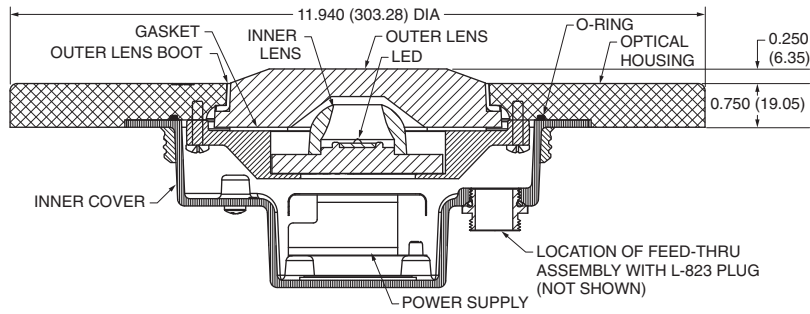

8" Fixture

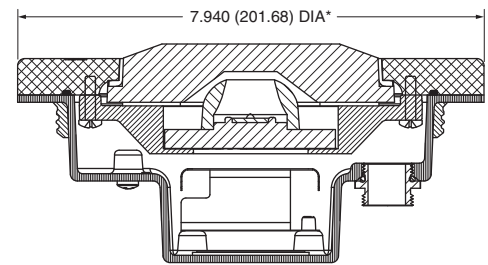

* All other dimensions and callouts equivalent to 12" Fixture.

Dimensions:	inches (mm)
Instruction Manual:	1026
Shipping Weight:	10.5 lbs (4.8 kg)
Shipping Volume:	0.7 cu ft (0.02 m ³)

Typical Photometric Data

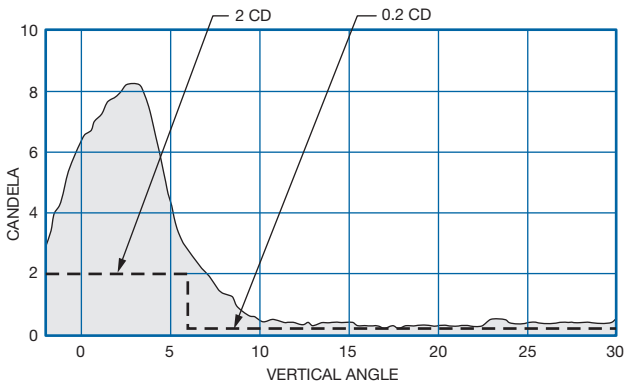

L-852T5 Taxiway Edge Light – LED

Accessories

Item Description	Catalog Number	Item Description	Catalog Number
12" Diameter Shallow Base – Aluminum	21238-X	Heat Shrink Kit – 1 Piece	10047-2154
8" Diameter Shallow Base – Aluminum	21431-X	Heat Shrink Kit – 2 Piece	10047-1425
Base: L867B, Class 1, 24" Deep	AC21242H200301	Isolation Transformer – 10/15W, 6.6/6.6 A	33015
Base: L868B, Class 1, 24" Deep	AC24242H200303	Isolation Transformer – 30/45W, 6.6/6.6 A	33001
Connector Kit – L823, 8 AWG	823KP-D4-D4		

Renewal Parts

Description	Part Number	Description	Part Number
Bottom Cover Assembly	21306	LED Replacement Assembly (Blue)	21486
Feed Through Assy.	21122	O-Ring - Bottom Cover	10035-62
Gasket, for use with Shallow Base 21431	21381	Outer Lens	21254
LED Power Supply – Arctic/Heater	21444-5T-3	Outer Lens Boot	21256
LED Power Supply – Non Arctic/No Heater	21444-5T-1	Thermoswitch Replacement Kit	21326*

* Includes 10047-2943 Thermoswitch, 21320 Locking Bracket and 10033-81 Pop Rivet.

