

TEL-5

Medium Intensity Runway Threshold/End Light

Compliances:

FAA AC 150/5345-46: L-861SE

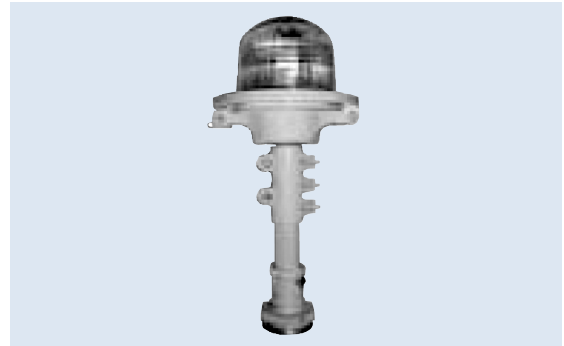

Applications

The TEL-5 is intended to enhance the visibility of thresholds on medium intensity runways that do not have approach lighting.

Features



- ETL Certified
- L861SE Fixture with 120W lamp
- Requires no tools to relamp - fixture hinges open for lamp access and ease, and is held shut by a spring clip
- Easy to level - unique swivel design allows fixture to be leveled by loosening and tightening one exterior fastener
- Easy to change filters - twist in place
- 300 MPH wind tested
- Modular design
- Utilizes 6.6 amp quartz bi-pin lamp
- Die-cast aluminum housing, painted yellow
- Available in heights 14 inches to 30 inches
- Standard 2" Threaded Frangible Coupling

Ordering Information

	8	6	1	5	-	S		-		-	
<p>Fixture Type: _____</p> <p>Model 5: _____</p> <p>Type S: _____</p> <p>Beam Color & Type: _____</p> <p>Height in Inches: _____</p> <p>Options: _____</p>	<p style="margin: 0;">GX = Green/Blank</p> <p style="margin: 0;">GR = Green/Red</p> <p style="margin: 0;">Standard Height = 14 inches</p> <p style="margin: 0;">Available in 2-inch increments to 30 inches maximum</p> <p style="margin: 0;">1 = 1.5"-12 UNF threaded aluminum frangible coupling</p> <p style="margin: 0;">3 = Level adjustment lever in place of standard hex socket cap screw</p> <p style="margin: 0;">EX = Extra strength fixture for high wind and heavy snow areas. This option replaces the standard frangible coupling, housing column, and clamps with extra strength components.</p>										

Outline Drawing

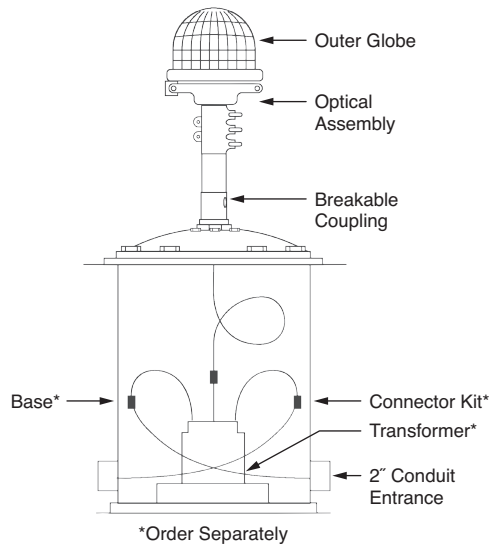

Typical Photometric Data

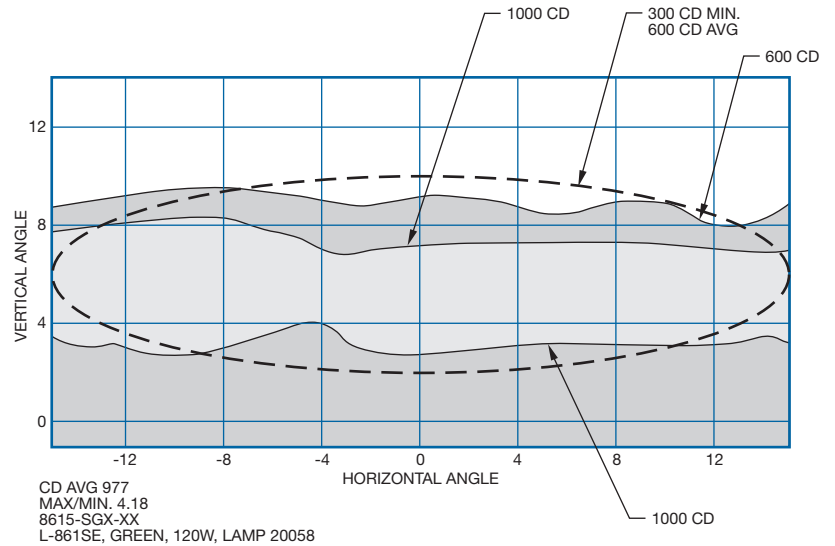

Accessories

Description	Catalog Number	Shipping Weight		Shipping Volume	
		lb.	kg.	cu.ft.	cu.m.
Base L-867, Class I, 24" Deep	AC21242H200301	52	23.6	2.6	0.074
Baseplate, 1.5" Hub, Painted Steel	AP1935	8	3.6	0.14	0.004
Baseplate, 2" Hub, Painted Steel	AP1932	8	3.6	0.14	0.004
Connector Kit L-823, 8 AWG Stranded, 0.32" to 0.43" O.D.	823KP-D4-D4				
Leveling Fixture	50359				
Transformer, 100 W, 6.6/6.6A	33004	8.6	3.9	0.3	0.009

Renewal Parts

Description	Part Number	Description	Part Number
Clear Outer Globe	50376-C	Frangible Coupling 2" Aluminum—EX Option	60683-E
Clear/Blank Outer Globe	50376-C/X	Globe Gasket	40989
Filter Gasket	50351	Green Inner Filter	50360-G
Filter Spring	50366	Lamp, 120W, 6.6A, Bi-Pin	20058
Frangible Coupling 1.5"	50186	Red Inner Filter	50360-R
Frangible Coupling 2" Aluminum	50184		

Instruction Sheet: 2121 (standard fixtures)
2325 (-EX fixtures)

Shipping Weight: 4.5 lbs.
2.0 kg.

Shipping Volume: 0.31 cu. ft.
.009 cu. m.

