

PRO III™ TCL 6 Taxiway Centerline Light

Compliances:
FAA AC 150/5345-46: L-852 D
UFC 3-535-01

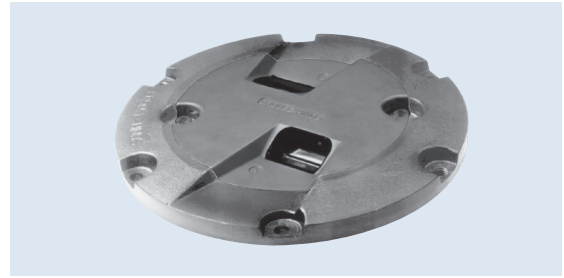

Applications

The TCL is a taxiway centerline light that is used primarily as a ground traffic aid during periods of low visibility to guide aircraft between the runway and the parking stand. The TCL is often a bidirectional light (using two 32 W lamps), but it also may be a unidirectional light (using one 32 watt lamp) on certain taxiways, such as high speed turnoffs.

Features



- ETL Certified
- Low profile, < .25" (6 mm) – FAA Style 3
- Unique combination of high-strength aluminum optical assembly and ductile iron outer ring for snow plow protection
- Low power consumption
- Few parts to stock
- Easy to maintain – no sealant required for prism or feed-through assembly replacement
- Pressure test plug for seal integrity verification
- Long lamp life – Quartz Halogen, 32 W

Ordering Information



Fixture Type: _____
D = L-852D (Wide, Cat. III)

Color Filters: _____
GX = Green/Blank YY = Yellow/Yellow
YX = Yellow/Blank GY = Green/Yellow
GG = Green/Green

Fixture Diameter: _____
12F = Optical assembly with 12" FAA support ring
NSR = Optical assembly without support ring
(See note 2; next page)

L-823 Plug Connection: _____
P1 = One plug (Blank color units will have a threaded cap installed.)
P2 = Two plugs (Two color units only. Note: For this feature only, blank is not considered a color.)

Options: _____
G = External gasket between optical assembly and support ring
(Note: Optical assemblies with external gasket will only fit support rings marked "G" on top surface.)

Outline Drawing

Dimensions:	inches (mm)
Instruction Manual:	2803
Shipping Weight:	23.0 lbs. 10.4 kg
Shipping Volume:	0.7 cu. ft. 0.02 m ³

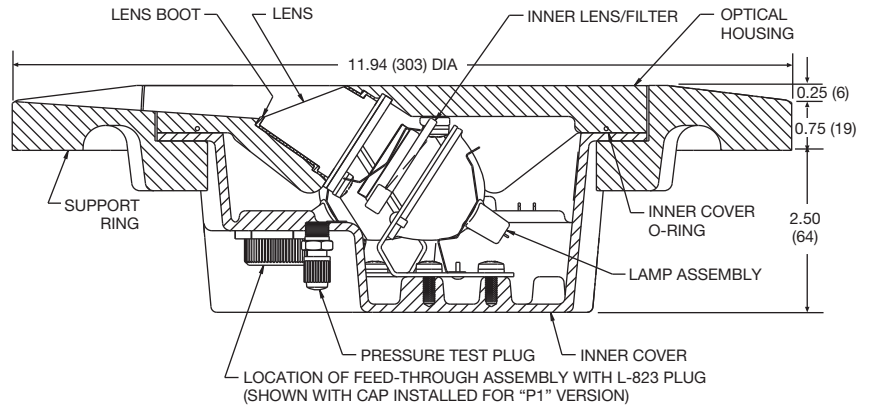

Typical Photometric Data

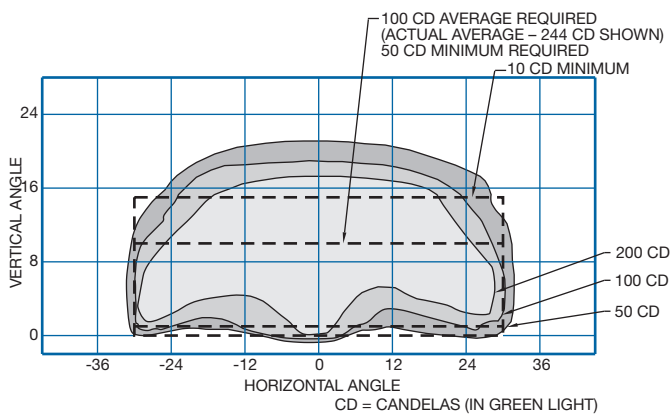

FAA L-852D , Wide (Curved Section), CAT III

Accessories

Item Description	Catalog Number	Item Description	Catalog Number
Base: L-868B, Class I*, 24" Deep	AC24242H200303	Isolation Transformer – 45 W, 20/6.6 A	33002
Connector Kit – L-823, 8 AWG, 0.32" to 0.43" O.D.	823KP-D4-D4	Isolation Transformer – 45 W, 6.6/6.6 A	33001
Heat Shrink Kit – 1 Piece	10047-2154	Isolation Transformer – 65 W, 6.6/6.6 A	33003
Heat Shrink Kit – 2 Piece	10047-1425	Lifting Tool (for outer ring)	19999

* Sectional bases may be required depending upon the paving technique

Renewal Parts

Description	Part Number	Description	Part Number
External support ring gasket	21180	Gasket – Bottom Cover	21124*
Feed-through Assembly – 1 Lamp, 1 Connector	21122	Lamp – 32 W, 6.6 A	21127
Feed-through Assembly – 2 Lamp, 1 Connector	21121	Lamp Bracket Assembly	21461
Filter – Green (wide)	21130-G	Lens Replacement Kit – Clear	21126-C
Filter – Yellow (wide)	21130-Y	O-Ring – Bottom Cover	10035-62*
Fresnel gasket	21132	Spare Optical Assembly	852D6-XX-NSR-XX

* For older unit without o-ring groove in top aluminum forging see instruction manual 2803.

Note:

- Lens Replacement Kit includes lens, lens boot, lens retaining gasket, gasket lubricant, and lens retaining bracket and screws.
- 852D6 fixtures and rings are not compatible with 852D3 fixtures and rings.

