

SPC

Series Plug Cutout Type S-1 (MODEL 2)

Compliances:
FAA AC 150/5340



SPC2

Applications

The Series Plug Cutout Type S-1 is a device installed at the constant current regulator (CCR) output through which the series circuit passes. With the handle assembly removed, the SPC isolates the CCR output from airfield series loop for maintenance personnel safety. The SPC also shorts the series loop and shorts the regulator secondary aiding in maintenance checks and troubleshooting.*

Features

- Provides positive proof that the series circuit cannot be energized during maintenance
- Shorts the series circuit for maintenance continuity checks
- Shorts the regulator secondary for maintenance checks
- Body constructed of high strength engineered plastics
- Suitable for 6.6A or 20A circuits
- Protected against arcing

Outline Drawings

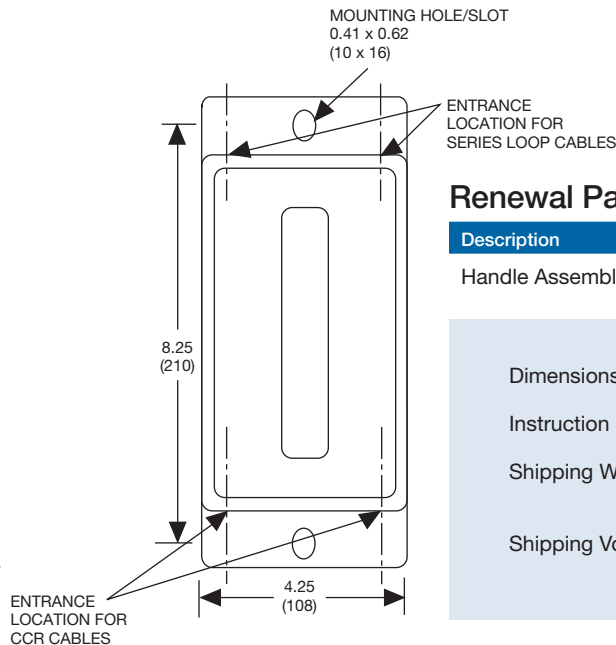
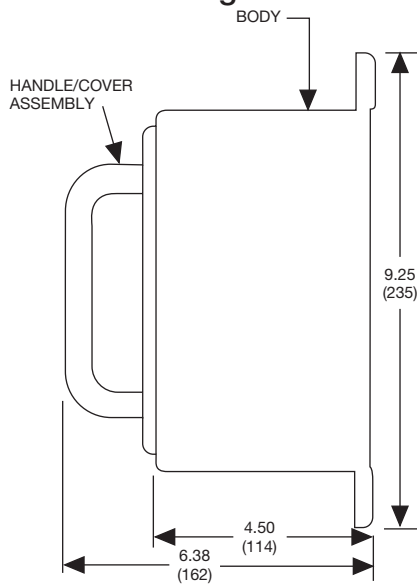

* Primary power to the CCR should always be shut-off and locked out before removing the handle assembly.

Ordering Information

3 0 7 7 5

Catalog Number: _____

Wiring Diagrams

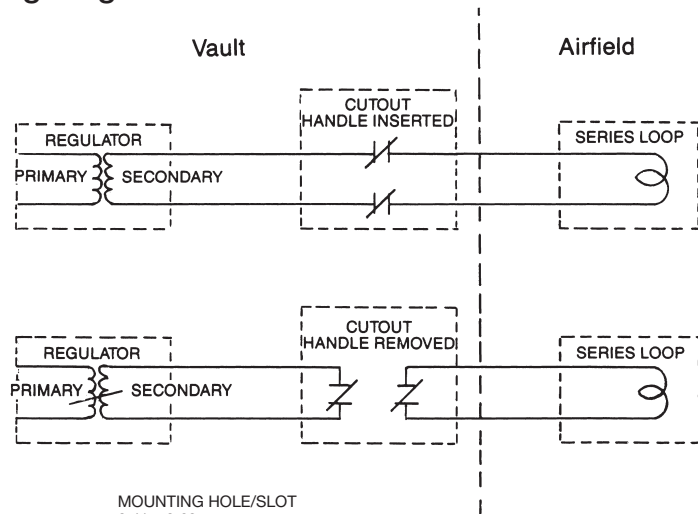

Renewal Part

Description	Catalog Number
Handle Assembly	30779
Dimensions:	inches (mm)
Instruction Sheet:	9208
Shipping Weight:	4.0 lbs. 1.8 kg.
Shipping Volume:	0.2 cu.ft. 0.006 cu.m.

