

PRO III™ SBGL

Inset Stop Bar / Runway Guard Light

Compliances:

FAA AC 150/5345-46: L-852 G and L-852S

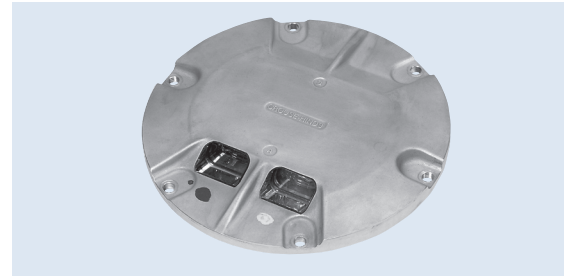

Applications

The SBGL fixtures are used for runway incursion protection and traffic control on taxiways just before active runways. They are required for SMGCS operations during low visibility conditions as defined in FAA AC 150/5340-30 and AC 120-57A. This unidirectional light is designed for use in all weather conditions with any kind of control system including the Digitrac® Control and Monitoring System.

Features



- ETL Certified
- Low profile, < .25" (6 mm) – FAA Style 3
- High-strength forged aluminum
- Low power consumption
- Few parts to stock
- Easy to maintain – no sealant required for prism or feed-through assembly replacement
- Pressure test plug for seal integrity verification
- Long lamp life – Quartz Halogen, 105 W
- Control and Monitoring – Fixture can be supplied with a Crouse-Hinds Logitrac for individual lamp control and monitoring as required for flashing guard light operation or stop bar control. Contact Crouse-Hinds for more info

Ordering Information



Fixture Type: _____
GS = L-852/S, Stop bar/Runway guard light

Color Filters: _____
YR = Yellow (Left side)/Red (Right side)
YX = Yellow (Left side)/Blank (Right side)
XR = Blank (Left side)/Red (Right side)

L-852 Plug Connection: _____
P1 = One Plug (One-color units only. Blank is not considered a color.)
P2 = Two Plugs (Two-color units only. Blank is not considered a color.)

Outline Drawing

Yellow

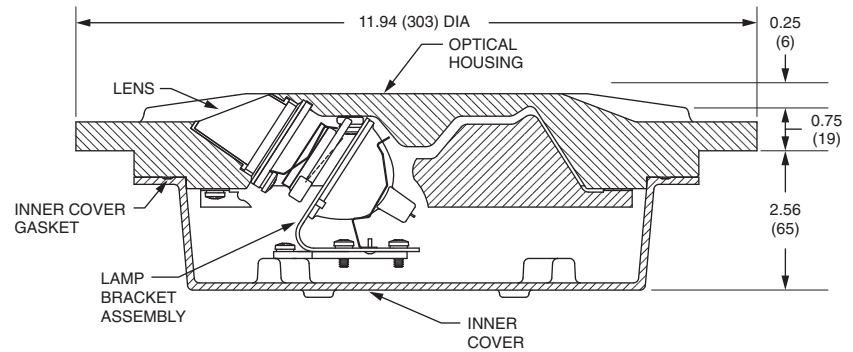

Red

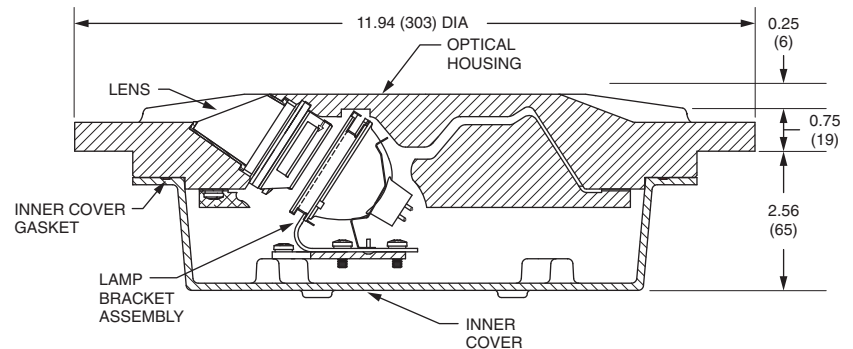

Dimensions:	inches (mm)
Instruction Manual:	2106
Shipping Weight:	16.0 lbs. 7.3 kg
Shipping Volume:	0.7 cu. ft. 0.02 m ³

Typical Photometric Data

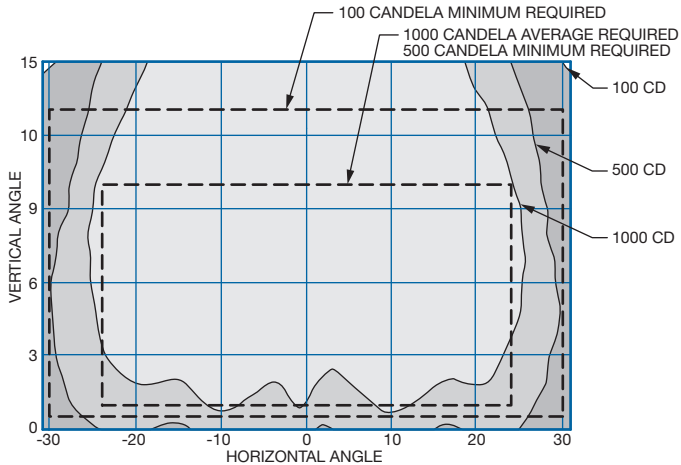

L-852G Runway Guard Light-Yellow

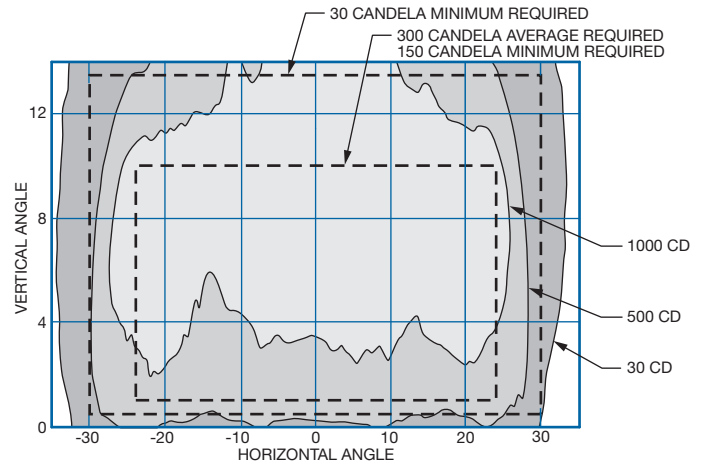

L-852S Stop Bar Light-Red

Accessories

Catalog Number	Item Description	Catalog Number	Item Description
AC24242Q200303	Base L-868B, Class I*, 24" Deep	19999	Lifting Tool (for outer ring)
33004	Isolation Transformer – 100 W, 6.6/6.6 A	T6540-03-01-00	Logitrac Device, L852GS
33005	Isolation Transformer – 100 W, 20A/6.6 A	T6540-02-01-00	Logitrac Device, L852s
823KP-D4 -D4	Connector Kit – L-823, 8AWG, .32" to .43" O.D.	T6540-01-01-00	Logitrac Device, L852g
10047-2154	Heat Shrink Kit – 1 piece		
10047-1425	Heat Shrink Kit – 2 piece		

* Sectional bases may be required depending upon the paving technique.

Renewal Parts

Part Number	Description	Part Number	Description
21128	Lamp – 105 W, 6.6 A	21140	Gasket - Bottom Cover
21126-AR	Lens Replacement Kit	21122	Feed-through Assembly – 1 Lamp, 1 Connector
21130-TY	Fresnel Filter – Yellow	10048-25	Gasket Lubricant – 5.3 oz Container
21490	Filter – Red		
21488	Bracket – Red Filter		
21491	Fresnel Filter – Clear		
21487	Bracket – Clear Fresnel Filter		

Note:

1. Lens Replacement Kit includes lens, lens boot, lens retaining gasket, gasket lubricant, and lens retaining bracket and screws.

