

REIL

Runway End Identifier Lights

Compliances:

- FAA/AC 150/5345-51; L-849 A,B,E,F
- ICAO Annex 14



Applications

The primary application of a REIL system is to positively identify the end or the threshold of a visual or instrument non-precision runway. This REIL system consists of two synchronized flashing lights. One flasher unit is located at each side of the runway threshold.

Features



- ETL Certified
- CSA Certified
- Easy to install – each REIL unit consists of a flash head and a control box, mounted on the same support leg(s).
- Easy to maintain – special tools are not required.
- Does not require separate control cabinet – REIL Master Unit with integral system control.
- Elapsed time meter
- Safety interlock in each control box and flash head.
- Weather resistant – painted parts are coated with U.V. resistant paint, electrostatically applied.

Note: Each current (series circuit) operated REIL must be powered by a dedicated 4kW (minimum) constant current regulator.

Ordering Information

How to Order: To the Basic Catalog Number, add the symbols for FAA Style and Input Power, as shown below. Add Option numbers as required.

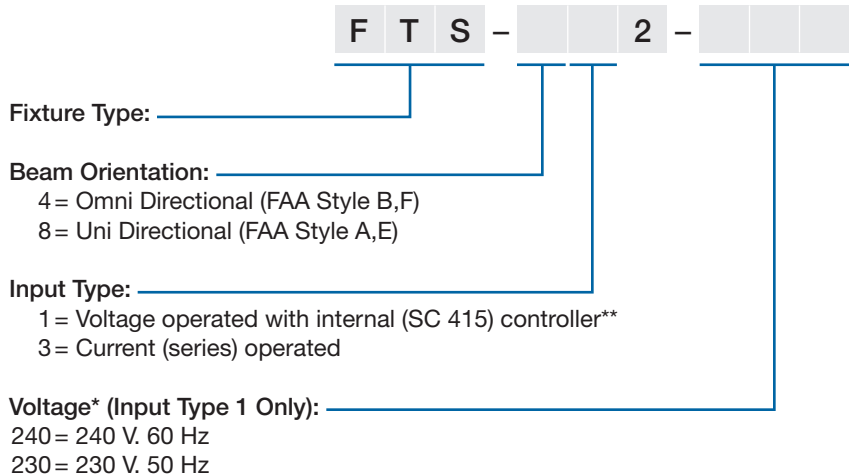

* For optional 120 V, 60 Hz consult factory
 FTS SERIES products are manufactured by Flash Technology, Franklin, TN.
 ** For optional current sensing control of the voltage operated REIL, also order FTC-435 Controller and (1) 30/45W isolation transformer

Technical Data

Instruction Manual: FTS 400/800
 FTS 430/830

Primary Power:

Voltage Unit, 240VAC +10% 60Hz / 230VAC +10% 50Hz , 1 Phase
 Current Unit, Direct connect to secondary of standard FAA type L830

Isolating Transformer

120 Watts (High) 85 Watts (Med) 65 Watts (Low)
 300 Volt Amperes (High Intensity)

Effective Intensity:

Style A, E = 20,000, 2000, 450 effective candelas.
 Style B, F = 300 ± 50%, 1,500 ± 5% and 5,000 ± 5% effective candelas

Flash Rate:

60 Flashes per minute (400)
 120 Flashes per minute (800)

Beam Pattern:

Omnidirectional coverage: 360 degrees horizontal, 8 degrees vertical
 Unidirectional coverage: 30 degrees horizontal, 10 degrees vertical

Outline Drawings

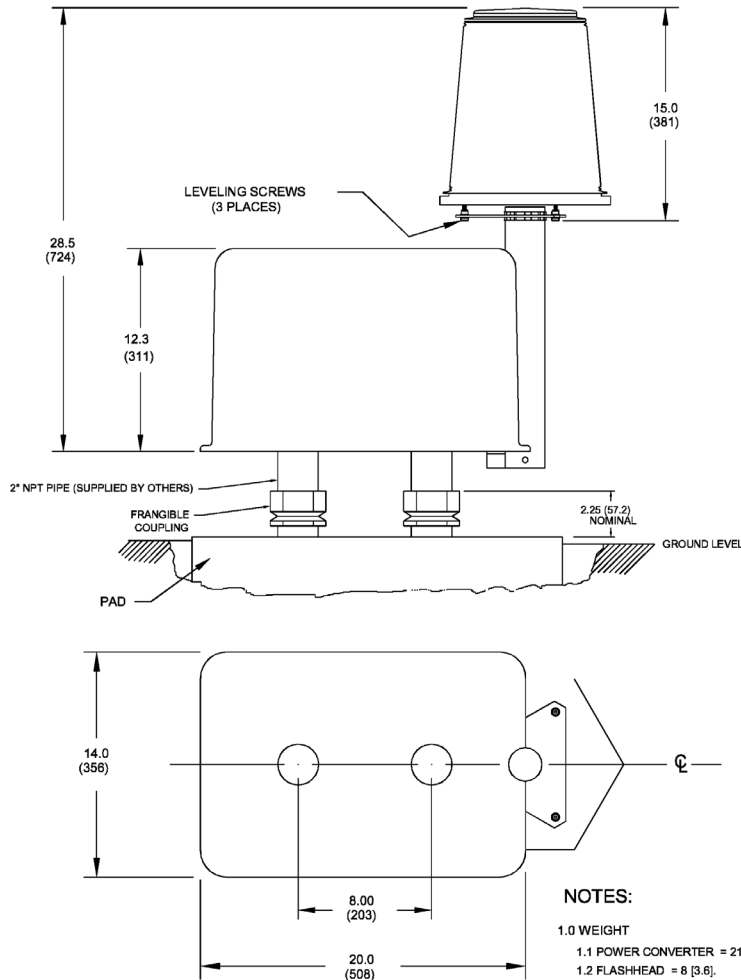

FTS 4 Series Co-Mounted
Omni Directional

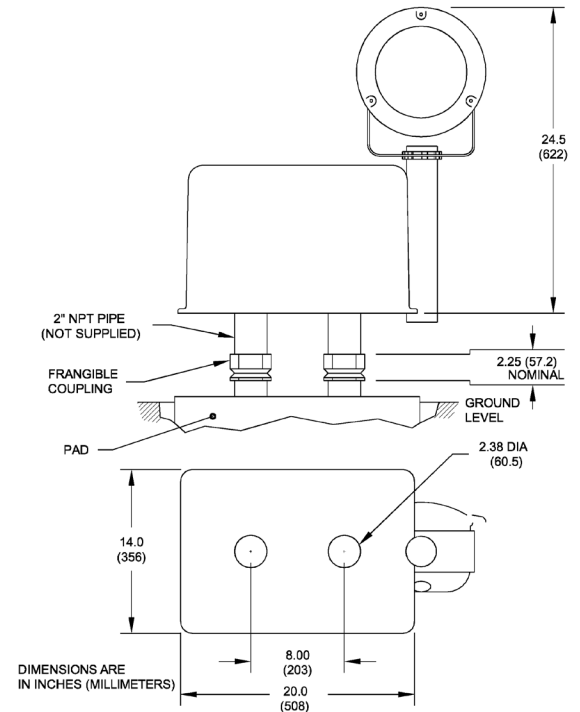

FTS 8 Series Co-Mounted
Uni Directional

Dimensions: inches (mm)

Renewal Parts

Description	Part Number	Description	Part Number
Clamp, Lens (FH400)	3893201	RC Network RC101 (FH400 & FH800)	1403411
Flash Tube FT 101 (FH400)	8384329*	Retaining Bezel (FH800)	3735202
Flash Tube FT 101 (FH800)	4901700*	Spacer, Ceramic (FH400)	5900844
Lens (FH400)	8743701	Terminal Screw Lug (FH400)	3379102
Post, Ceramic (FH800)	5900842	Trigger Transformer (FH400 & FH800)	8288201

* Recommended as a spare part.

Shipping Weights and Volumes

REIL Catalog Number	Shipping Weight		Shipping Volume	
	Lbs.	Kg.	Cu.Ft.	Cu.M.
FTS 4 Series	29	13.1	37	1.048
FTS 8 Series	25	11.3	37	1.048

