

Pro V LED Series

RETIL-LED, ICAO

Rapid Exit Taxiway Indicator Light

Compliances:

- FAA AC 150/5435-46D
- Engineering Brief No. 67c
- ICAO Annex 14
- IEC TS 61827
- NATO: STANAG 3316



Applications

The RETIL is a rapid exit indicator light that is used primarily as a ground traffic aid on taxiways to alleviate traffic. The rapid exit is an unidirectional yellow light, with 12W power consumption.

Features

- 8" outer diameter (12" optional)
- 0.25" height above surface
- Depth below flange: 1.38"
- Light prism size 1.57" x 0.24"
- Dust and Water tightness: IP68
- Overall lifetime* up to 20 years
- Useful Lamp life** (LED) > 50,000h
- Nominal Current: 6.6A (0-100%)
- Power consumption (@6,6A): 12W per side
- Power factor >95% at nominal current
- Temperature***: -40°C to +85°C (-40°F to +185°F)
- Internal serial interface for diagnostics and parameterization
- Arctic kit (optional). Additional 14 W while operating
- Integrated single lamp control (optional; contact factory for details)

* Not including consumable items

** Based on 24h cycle: 8h @55°C Air temperature + 1kW/m² solar radiation / 16h@25°C

*** Measured on cover surface

Ordering Information

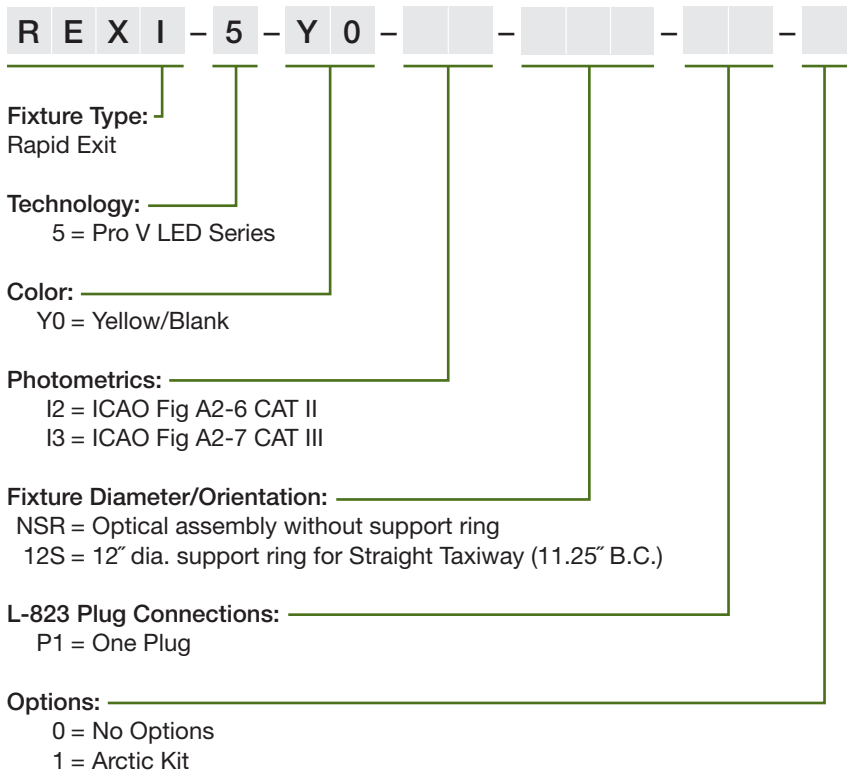

Outline Drawings

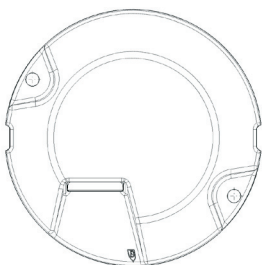

Uni-Direction

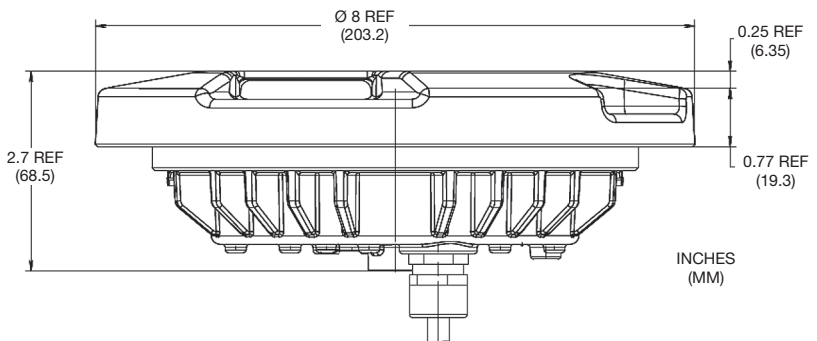

Typical Photometric Data

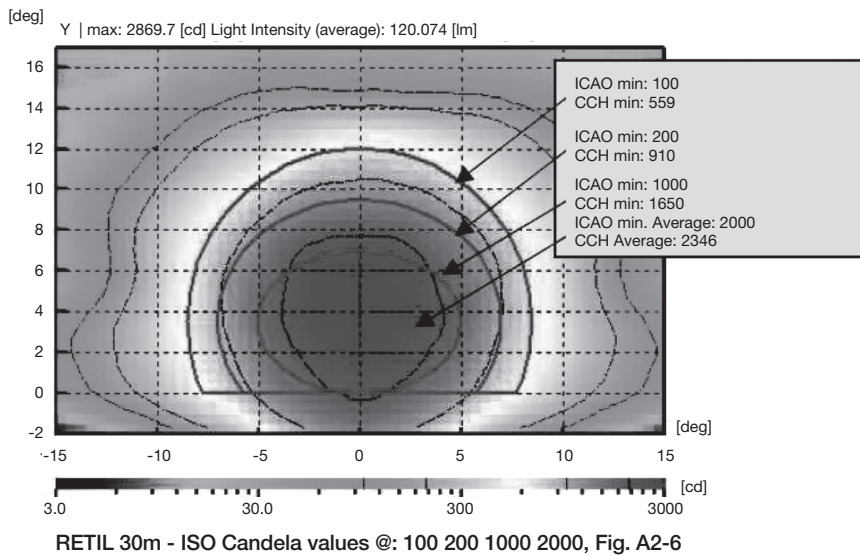
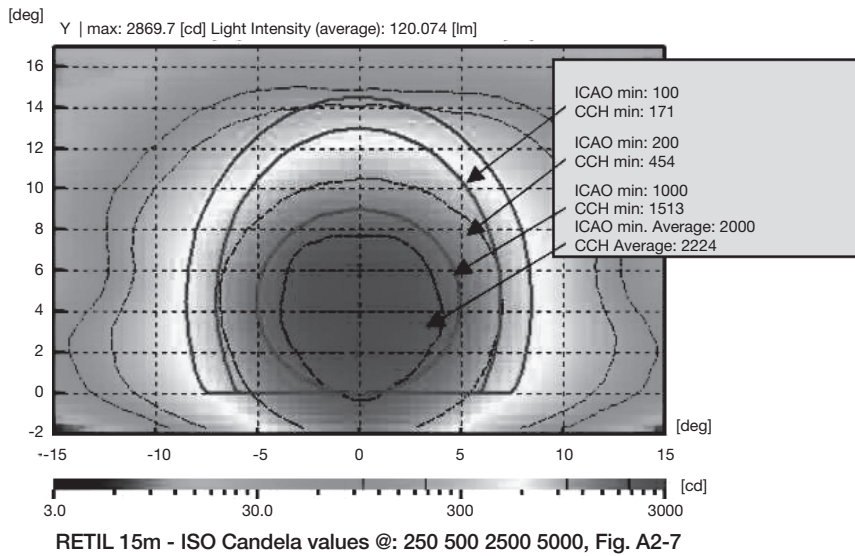

Accessories

| Description | Part Number | Description | Part Number |
|----------------------------------|----------------|--|-------------|
| Base: L-868B, Class I, 24" Deep* | AC24242H200303 | Isolation Transformer – 15/20 W, 6.6/6.6 A | 33365 |
| Bolt Set | 22500 | Isolation Transformer – 30/45 W, 6.6/6.6 A | 33001 |
| Heat Shrink Kit – 1 Piece | 10047-2154 | | |

* Two-piece can may be required depending upon the paving technique.

Renewal Parts

| Description | Part Number | Description | Part Number |
|---|-------------|--|-------------|
| 12" Dia. FAA Support Ring Straight (11.25" B.C.) | 22504 | 2 Power Supplies/Fixture Base w/ (1) L-823 Plug | 22523 |
| Connector Kit – L-823, 8 AWG, 0.32" to 0.43" O.D. | 823KP-D4-D4 | 2 Power Supplies/Fixture Base w/ (2) L-823 Plugs | 22508 |
| Connector Kit for Base | 22522 | Prism Replacement Kit (includes Prism Gasket) | 22502 |
| Gasket, Base Interior | 22501 | Yellow Cartridge Taxiway | 22513 |
| Power Supply/Fixture Base w/ (1) L-823 Plug | 22507 | | |

