

PRO III™ IREL Inset Runway Edge Light

Compliances:

- FAA AC 150/5345-46: L-850C
- ICAO Annex 14: Fig. A2-9
- Transport Canada Specification TP 312: Fig. B1.10
- UFC 3-535-01

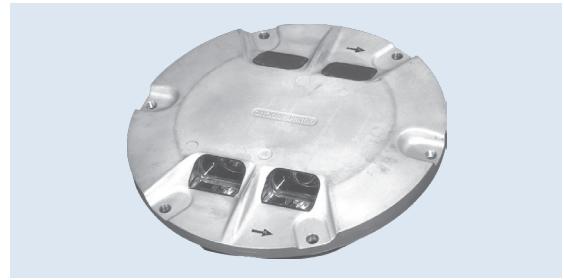

Applications

The IREL is a high intensity bidirectional light (using four 48 watt lamps.) This fixture is used where taxiways intersect the runway and any other runway edge locations where it is impractical to use an elevated light.

Features



- ETL Certified
- Low profile, < .25" (6mm) – FAA Style 3
- Low power consumption
- Few parts to stock
- Beam orientation can be easily changed to left or right toe-in
- Easy to maintain – no sealant required for prism or feed-through assembly replacement
- Pressure test plug for seal integrity verification
- Long Lamp Life – Quartz Halogen, 48 W, 6.6A
- High-strength forged aluminum

Ordering Information

8 5 0 C 3 - - -

Fixture Type: _____

Color* : _____

- CC = Clear/Clear
- CY = Clear/Yellow
- YC = Yellow/Clear
- CR = Clear/Red
- RC = Red/Clear
- YR = Yellow/Red
- RY = Red/Yellow
- CX = Clear/Blank
- XC = Blank/Clear
- YX = Yellow/Blank
- XY = Blank/Yellow
- RX = Red/Blank
- XR = Blank/Red
- GY = Green/Yellow
- YG = Yellow/Green

L-823 Plug Connection: _____

P1 = One plug

P2 = Two plugs (Two color units only. Blank is not considered a color.)

* Refer to the color symbol position:
The first color is left toe-in;
The second color is right toe-in.

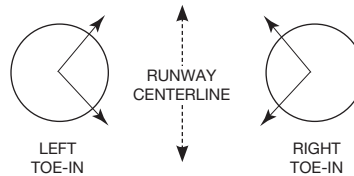

Outline Drawing

Dimensions:	inches (mm)
Instruction Manual:	9929
Shipping Weight:	16.0 lbs. 7.3 kg
Shipping Volume:	0.7 cu. ft. 0.02 m ³

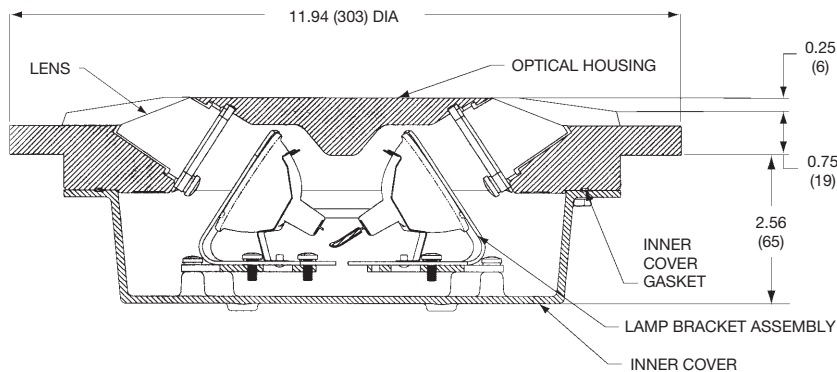

Typical Photometric Data

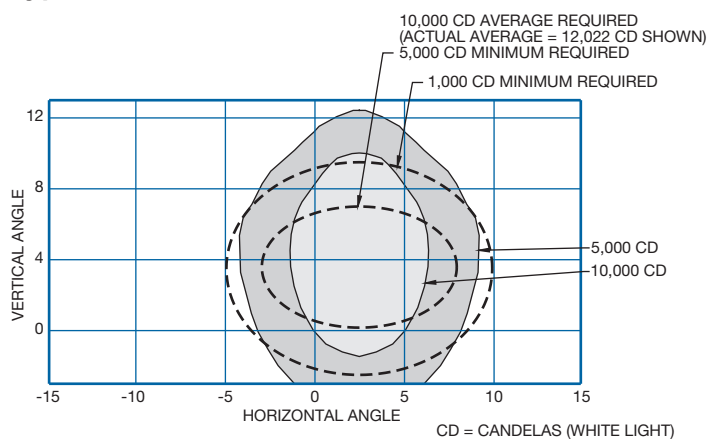

L-850C Inset Runway Edge Light – White

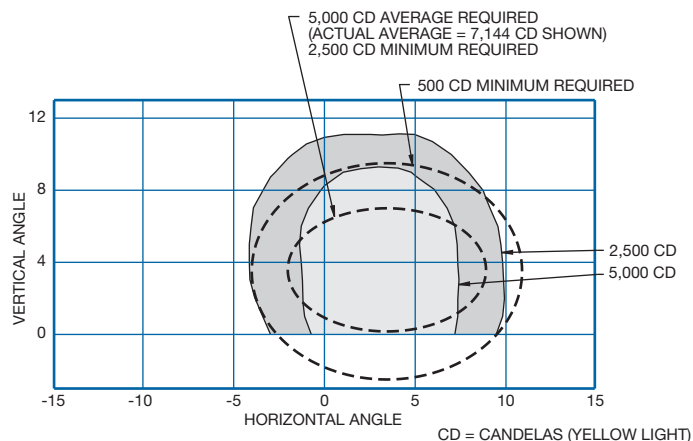

L-850C Inset Runway Edge Light – Yellow

Accessories

Catalog Number	Item Description	Catalog Number	Item Description
AC24242Q200303	Base: L-868B, Class I, 24" Deep*	823KP-D4-D4	Connector Kit – L-823, 8 AWG, .32" to .43" O.D.
33004	Isolation Transformer – 100 W, 6.6/6.6 A	10047-2154	Heat Shrink Kit – 1 Piece
33005	Isolation Transformer – 100 W, 20/6.6 A	10047-1425	Heat Shrink Kit – 2 Piece
33006	Isolation Transformer – 200 W, 6.6/6.6 A	19999	Lifting Tool
33007	Isolation Transformer – 200 W, 20/6.6 A	21151	Adapter Ring – 15" L-868C Base (11.25" bolt circle to 14.25" bolt circle)

Renewal Parts

Part Number	Description	Part Number	Description
21116	Lamp – 48 W, 6.6 A	21140	Gasket – Bottom Cover
21126-C	Lens Replacement Kit – Clear	21122	Feed-through Assembly – 1 Lamp, 1 Connector
21126-Y	Lens Replacement Kit – Yellow	10048-25	Gasket Lubricant – 5.3 oz. Container
21126-R	Lens Replacement Kit – Red		

* Fixture with total lamp wattage greater than 150W should not be mounted on 12" diameter bases less than 20" (500mm) deep. Class II bases are not recommended for this application.

Note:

1. Lens Replacement Kit includes lens, lens boot, lens retaining gasket, gasket lubricant, and lens retaining bracket and screws.

