

PRO III™ FTCL Taxiway Centerline Light

Compliances:

FAA AC 150/5345-46: L-852 A, B, C and D
UFC 3-535-01

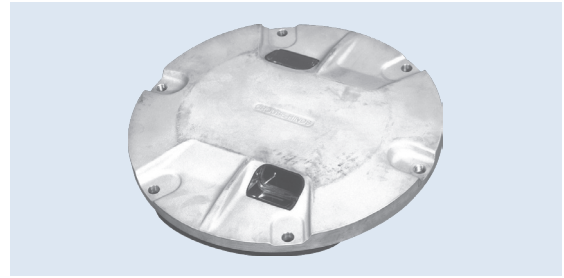

Applications

The FTCL is a taxiway centerline light that is used primarily as a ground traffic aid during periods of low visibility to guide aircraft between the runway and the parking stand. The FTCL is often a bidirectional light (using two 32 W lamps), but it also may be a unidirectional light (using one 32 watt lamp) on certain taxiways, such as high speed turnoffs.

Features



- ETL Certified
- Low profile, < .25" (6 mm) – FAA Style 3
- Low power consumption
- Few parts to stock
- Easy to maintain – no sealant required for prism or feed-through assembly replacement
- Pressure test plug for seal integrity verification
- Long lamp life – Quartz Halogen, 32 W, L-852 A-D

Ordering Information



Fixture Type:

- A = L-852A (Narrow, Cat. II)
- B = L-852B (Wide, Cat. II)
- C = L-852C (Narrow, Cat. III)
- D = L-852D (Wide, Cat. III)

Color Filters:

- GX = Green/Blank YY = Yellow/Yellow
- YX = Yellow/Blank GY = Green/Yellow
- GG = Green/Green

L-823 Plug Connection:

- P1 = One plug (Blank color units will have a threaded cap installed.)
- P2 = Two plugs (Two color units only. Note: For this feature only, blank is not considered a color.)

Outline Drawing

Dimensions:	inches (mm)
Shipping Weight:	16.0 lbs. 7.3 kg
Instruction Manual:	2215
Shipping Volume:	0.7 cu. ft. 0.02 m ³

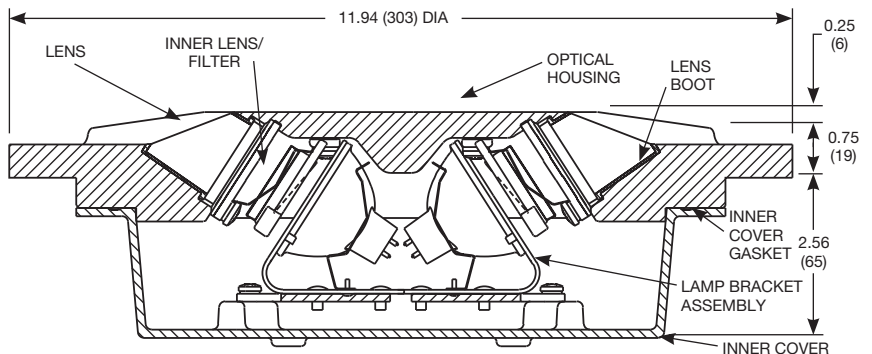

Typical Photometric Data

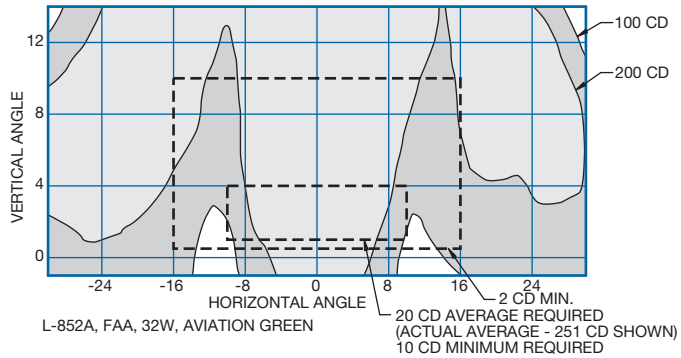

FAA L-852A Narrow (Straight Section), CAT II

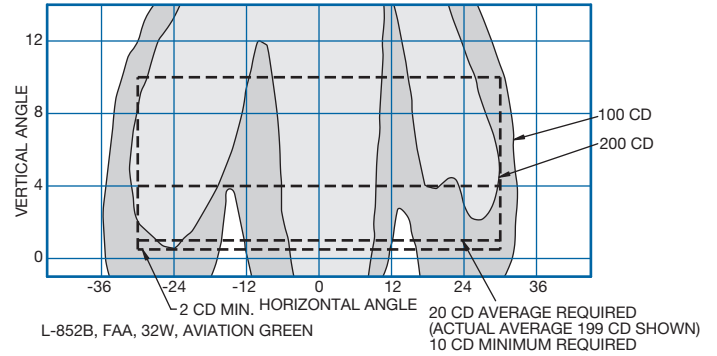

FAA L-852B Wide (Curved Section), CAT II

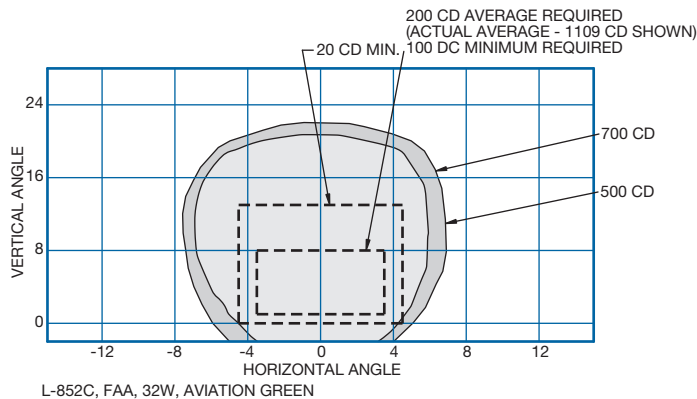

FAA L-852C Narrow (Straight Section), CAT III

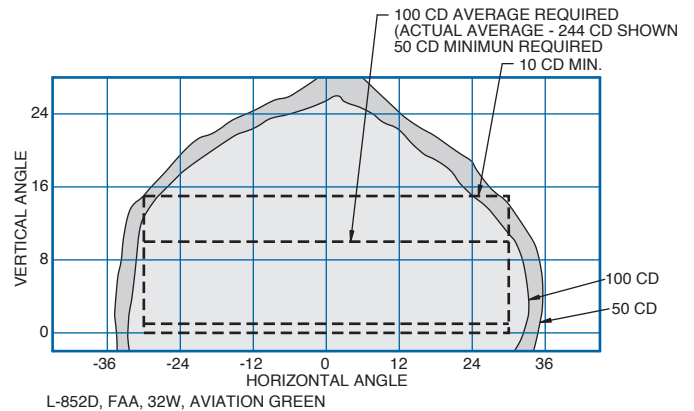

FAA L-852D Wide (Curved Section), CAT III

Accessories

Catalog Number	Item Description	Catalog Number	Item Description
AC24242H200303	Base: L-868B, Class I*, 24" Deep	823KP-D4-D4	Connector Kit - L-823, 8 AWG, .32" to .43" O.D.
33001	Isolation Transformer - 30/45 W, 6.6/6.6 A	10047-2154	Heat Shrink Kit - 1 Piece
33002	Isolation Transformer - 30/45 W, 20/6.6 A	10047-1425	Heat Shrink Kit - 2 Piece
33003	Isolation Transformer - 65 W, 6.6/6.6 A	19999	Lifting Tool
33004	Isolation Transformer - 100 W, 6.6/6.6A		
33005	Isolation Transformer - 100 W, 20/6.6A		

* Sectional bases may be required depending upon the paving technique

Renewal Parts

Part Number	Description	Part Number	Description
21127	Lamp - 32 W, 6.6 A	21121	Feed-through Assembly - 2 Lamp, 1 Connector
21126-C	Lens Replacement Kit - Clear	21122	Feed-through Assembly - 1 Lamp, 1 Connector
21140	Gasket - Bottom Cover	10048-25	Gasket Lubricant - 5.3 oz Container
21436-G	Filter Assembly, Green, L-852B		
21436-Y	Filter Assembly, Yellow, L-852B		
21438-G	Filter Assembly, Green, L-852A		
21438-Y	Filter Assembly, Yellow, L-852A		
21133-G	Filter-Green, L852C		
21133-Y	Filter-Yellow, L852C		
L21130-G	Filter-Green, L852D		
L21130-Y	Filter-Yellow, L852D		

Note:

1. Lens Replacement Kit includes lens, lens boot, lens retaining gasket, gasket lubricant, and lens retaining bracket and screws.

