

CSS

Circuit Selector Switch

Compliances:

- FAA AC 150/5345-5: L-847
- Unified Facilities Criteria UFC 3-535-01

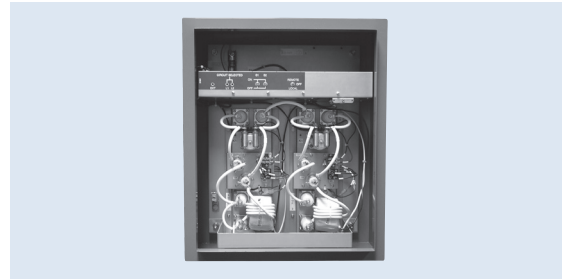

Applications

The CSS Circuit Selector Switch is connected to the output of a single constant current regulator and switches that output to one or more airfield lighting series circuits. Common applications include circuits for PAPIs, stopbars, and taxiway centerlines. The CSS can also be used as the interface between a standby backup regulator and several operating regulators.

Features



- ETL Certified (6.6 Amp circuits only)
- Simultaneous or Exclusive Switching
- For 6.6 or 20 Amp circuits
- Locally and Remotely Controllable
- Units may be interconnected to serve any number of circuits with a single regulator
- Clear Dead-Front Cover for high-voltage compartment with interlock switch
- Wall or Conduit Mounting
- Deenergized Switching to protect regulator circuitry
- Ambient Temperature Range -40° to +55°C

Ordering Information

How to Order: To the basic catalog number, add the number of series circuits to be switched and options from the chart below.

Example: An 84700-2-3-5 is a two-circuit selector switch for use with 48 VDC remote control. It features a relay for on/off remote back indication.

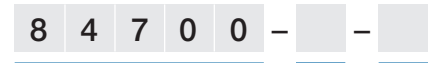

Basic Number: _____

Number of Series Circuits: _____
1 to 4

Options: _____

Refer to the chart below

Selection Chart

Standard Features & Options

Select one standard feature or option within each group. If the total number of options selected exceeds two (2), consult Cooper Crouse-Hinds for determination of compatibility.

GROUP A: INPUT VOLTAGE

Standard Feature	120 V, 50/60 Hz
Option -2	220-240 V, 50/60 Hz
Option- 15	480 V, 50/60 Hz

GROUP B: CONTROL VOLTAGE

Standard Feature	120 V (Internal Source)
Option -3	48 VDC (Remote Source)
Option -4	120 V (Remote Source)
Option -11	24 VDC (Remote Source)

GROUP C: STATUS INDICATION

Standard Feature	No Status Indication
Option -5	On/Off 6.6 A Circuit Current Monitor
Option -6	On/Off 20 A Circuit Current Monitor

GROUP D: CIRCUIT SELECTION

Standard Feature	Simultaneous: Any combination
Option -8	Exclusive: One circuit at a time
Option -9	Spare Regulator Switching: Prevents Interconnection of the two CCRs (2-circuit only)

GROUP E: CABINET TYPE

Standard Feature	NEMA 1-Indoor (Painted)
Option -10	NEMA 4-Indoor/Outdoor (Painted)
Option -13	NEMA 4X-Indoor/Outdoor (Stainless Steel)
Option -12	Cabinet Door Interlock Switch
Option - 14	Without Cabinet

Outline Drawings

Suggested Conduit Entrances
 A = Control Power
 B = Regulator
 C = Series Circuit

Dimensions:	inches			
	(mm)			
Instruction Manual:	9131			
Shipping Weight:	-1	-2	-3	-4
	70.0 lbs.	95.0 lbs.	95.0 lbs.	95.0 lbs.
	31.8 kg.	43.2 kg.	43.2 kg.	43.2 kg.
Shipping Volume:	3.4 cu. ft.	5.0 cu. ft.	5.0 cu. ft.	5.0 cu. ft.
	0.096 cu.m.	0.142 cu.m.	0.142 cu.m.	0.142 cu.m.

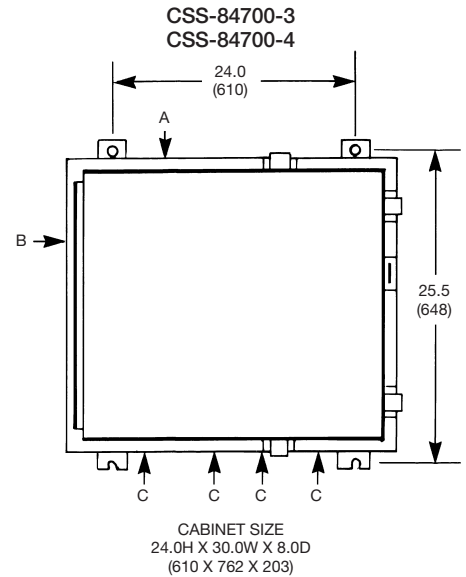
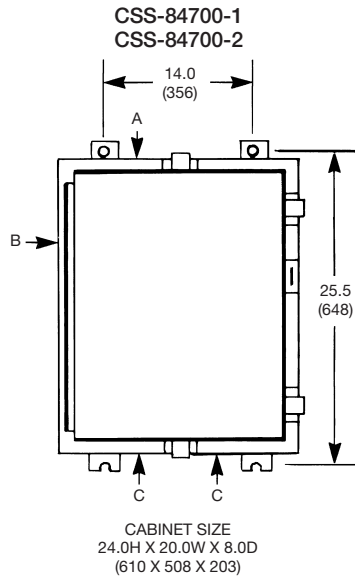

Wiring Diagrams

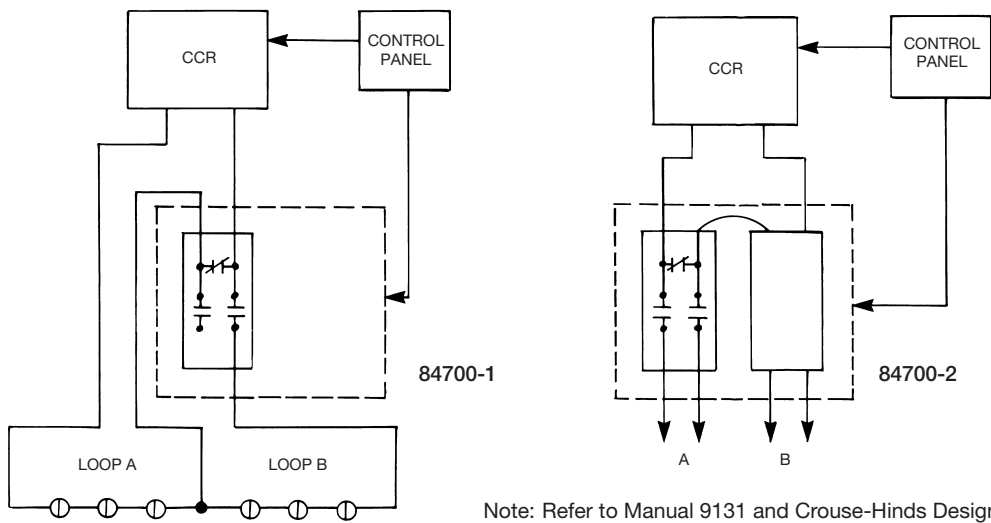

Note: Refer to Manual 9131 and Crouse-Hinds Design Guide for additional wiring configurations

Renewal Parts

Description	Part Number	Description	Part Number
Control Transformer 220/120 (84700 w/Option 2)	10047-1444	Relay Interface Harness	32849*
Current Sensing Circuit Board (84700-1 or 3 w/Option 5)	31978-1	Relay K1 SPNC	34197
Current Sensing Circuit Board (84700-2 or 4 w/Option 5)	31978-2	Relay Module K2 DPNO	34196*
Fuse 2.0 Amp (84700-1 or 2)	10047-1590	Timing Circuit Board (84700-1 or 2)	31955-1
Fuse 3.0 Amp (84700-3 or 4)	10047-1591	Timing Circuit Board (84700-1 or 2, w/Option 3)	31955-6
K1 and K2 Relay Module Assembly	30848-1	Timing Circuit Board (84700-1 or 2, w/Option 8)	31955-3
Relay Interface Assembly	34195*	Timing Circuit Board (84700-3 or 4)	31955-2
		Timing Circuit Board (84700-3 or 4, w/Option 3)	31955-7
		Timing Circuit Board (84700-3 or 4, w/Option 8)	31955-4

*These items must be ordered together

