

AV72

Radio Controlled Solar Aviation Light with Tactical IR Mode & 128bit Encryption

Compliances:

- ICAO Annex 14 Volume 1, 'Aerodrome Design and Operations', Fourth edition July 2004, paragraph 5.3.17.7
- FAA AC5345-46D L861T (High Intensity Mode)
- FAA AC5345-50B L863 (High Intensity Mode)
- CASA Manual of Standards Part 139 paragraph 9.13.15.1 and 9.13.15.3 Section 9.2.2.1 (High Intensity Mode)

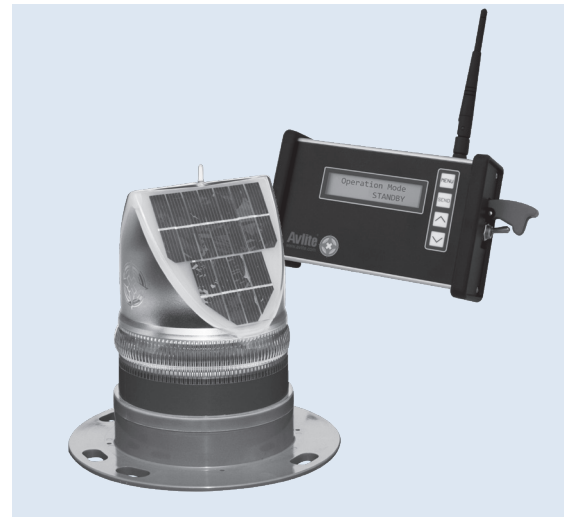

Applications

- Solar Airstrip Light
- Solar Barricade Light
- Solar Taxiway Light (ICAO)
- Solar Threshold Light

The AV72 is a self-contained solar powered omnidirectional aviation light with tactical IR mode, 128bit encryption and encrypted 2.4 GHz radio control. The AV72 solar powered LED airfield light has an internal RF module and antenna to receive encrypted command messages from the handheld radio controller.

Features

- CE Certified
- 2.4Ghz worldwide accepted radio control
- 128bit security encryption
- NGV compatible using IR LEDs
- 3-step intensity adjustment
- High capacity replaceable battery pack
- Made from tough, durable LEXAN® polycarbonate
- Dual internal high-performance solar panels for enhanced charging
- Internal RF module & antenna
- Tough UV-stabilized LEXAN® polycarbonate lens and light base
- LED aviation lens with 0 to +7° vertical divergence
- Band of retro-reflective tape

Ordering Information



Part Number: _____
 AV72 (comes standard with RF Radio Control & 6x IR LEDs)

Options

- External ON/OFF Switch:** _____
 S = External ON/OFF Switch
- External Battery Charging Port:** _____
 CP = External Battery Charging Port
- External Momentary Button:** _____
 MB = Manual Operation via External Momentary Button

Color (360 degrees): _____
 R = Red* W = White* A = Amber*
 G = Green* Y = Yellow* B = Blue*

Sectored Combinations

Various combinations of colored and IR lights listed above upon request. Please contact Crouse-Hinds with your requirements.

* 12x Visible Color LEDs & 6x IR LEDs

Note: Compatible with PALC system.

Typical Photometric Data

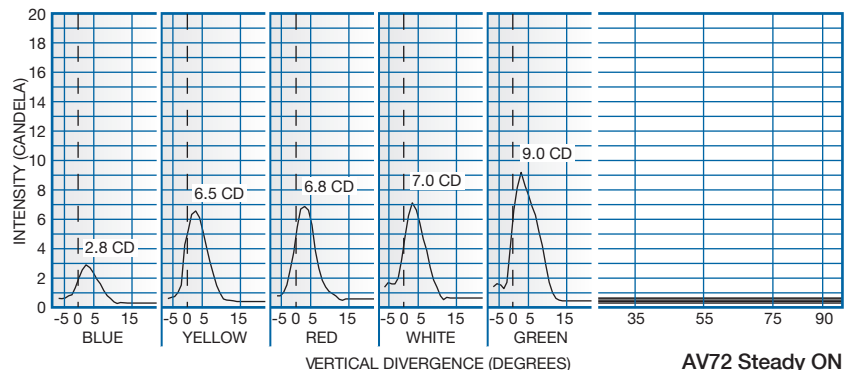

AV72 Steady ON

Specifications

Light Characteristics	
Light Source	12 visible ultra-high intensity LEDs and 6 infrared LEDs
Available colors	Red, Green, White, Yellow, Amber, Blue, Sectored Combinations
Peak Intensity (cd)*	Steady-on: Blue - 2.8 Red - 6.8 Green - 9.0 White - 7.0 Yellow - 6.5 Flashing: Blue - 5.5 Red - 18.2 Green - 21.9 White - 19.1 Yellow - 15.1
Horizontal Output (degrees)	360
Vertical Divergence (degrees)	0 to +7
Reflector Type	Omnidirectional 360° LED Reflector (US Pat. No. 6,667,582. AU Pat. No. 778,918)
Available Flash Characteristics	>250 including steady-on (user-adjustable)
Intensity Adjustments	Adjustable LOW / MEDIUM / HIGH
LED Life Expectancy (hours)	>100,000
Electrical Characteristics	
Operating Voltage (v)	3.6
Temperature Range	-40°F to +176°F (-40°C to +80°C)
Solar Characteristics	
Solar Module Type	Multicrystalline
Output (watts)	2.5 (2 x 1.25watt)
Solar Module Efficiency (%)	14
Charging Regulation	Microprocessor controlled
Power Supply	
Battery Type	High grade NiMH – Environmentally friendly
Battery Capacity (Ah)	16
Nominal Voltage (v)	3.6
Autonomy (nights)	Steady-on: >20 Low intensity dusk-till-dawn mode
RF Flash Synchronization	
Frequency	2.4Ghz ISM Band
Range	1.4km between 2 lights, relayed
Expandability	Peer to Peer Networking
Approvals	FCC / CE
Physical Characteristics	
Body Material	LEXAN® Polycarbonate – UV stabilized
Lens Material	LEXAN® Polycarbonate – UV stabilized
Lens Diameter (mm/inches)	140 / 5 1/2
Lens Design	External optics with interior flute design
Mounting	6 x 17mm holes on 200mm PCD
Weight (kg/lbs)	1.7 / 3 3/4
Product Life Expectancy	Up to 12 years
Environmental Factors	
Humidity	0 to 100%, MIL-STD-810F
Icing	22kg per square inch
Wind Speed	Up to 160kph
Shock	MIL-STD-202G, Test Condition G, Method 213B
Vibration	MIL-STD202G, Test Condition B, Method 204

* Intensity setting subject to solar availability

Outline Drawing

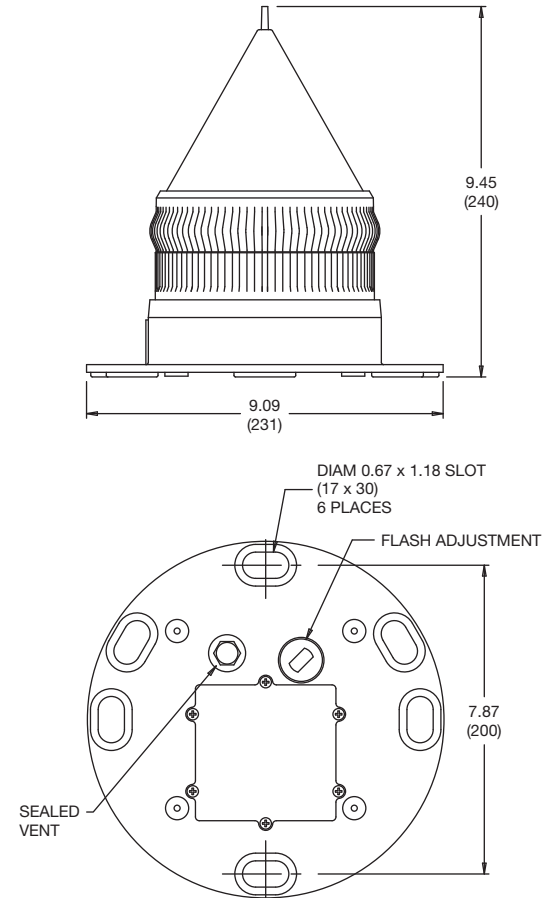

Dimensions: inches (mm)
Instruction Manual: AV72

Solar Aviation Light Products are manufactured by Avlite Systems, Victoria, Australia.

