

CUBEFuse Compact Circuit Protector Base (CCPB)

For Quik-Spec™ Coordination Panelboards



RoHS

The revolutionary Cooper Bussmann CCPB with CUBEFuse is designed as a fused branch circuit disconnect with fuse holder for the Cooper Bussmann Quik-Spec™ Coordination Panelboard. The CCPB with CUBEFuse simplifies selective coordination and allows for isolation of individual branch circuit loads for safe work practices.

Product Features and Benefits

- Uses finger-safe Class CF Low-Peak CUBEFuse with current-limiting, time-delay or fast-acting Class J performance*
- High Short-Circuit Current Ratings at 200kA
- Disconnect rated to provide means for load isolation
- Full voltage rated at 600Vac
- 125Vdc rated for 80A and below
- UL 98 Listed and suitable for branch circuit disconnect and branch circuit protection
- 1-, 2- and 3-pole versions are horsepower rated
- Patented rejection feature helps prevent overfusing
- Complies with UL and cULus
- Open fuse indication light per pole
- Additional open fuse indication can be provided by using the time-delay indicating CUBEFuse version
- Built-in switch/fuse interlock prohibits removing the fuse while energized
- Permanent lockout/tagout provisions
- Lock-On provision

*See data sheet 9000 for CUBEFuse specifications.

**For fuse performance under or above 25°C, consult fuse performance derating charts.

Specifications:

- CCPB Ampacity rejection breaks: 15A, 20A, 30A, 40A, 50A, 60A, 70A, 90A and 100A.
- 1-, 2- and 3-Pole versions
- For systems 600Vac (or less)
- Box lug loadside terminal:

15 - 60A:

- 18-6AWG (1-16mm²) single & dual rated, solid or stranded – 75°C, Cu only
- 4AWG (21.1mm²) single – 75°C, Cu only

100A:

- 18-1AWG (1-45mm²) single or dual rated, solid or stranded – 75°C or higher - Cu only
- 6AWG (16mm²) single – 75°C or higher - Cu only

- Box lug loadside terminal torque:

15-60A:

- 18-10AWG 20 Lb-In (1-6mm²/2.2N·m)
- 8-4AWG 35 Lb-In (10-21.1mm²/3.9N·m)

100A:

- 18-10AWG 25 Lb-In (1-6mm²/2.82N·m)
- 8-1AWG 40 LB-In (10-45mm²/4.52N·m)
- 6AWG 45Lb-In (16mm²/5.08N·m)

- Spade terminal load connection:

Max. 30A suitable for use with #8-32UNC screw

- Bolt-on style bus connector, #10-32-UNC Hex flange Phillips screw, torque to 25 Lb-In (2.8N·m)

- Lockout/tagout: 4mm shank lock

- Bolt-mounted design into Quik-Spec Coordination Panelboard bus

- Local indication: illumination requires closed circuit and minimum 90Vac operating voltage

- RoHS compliant

Agency Information:

UL 98 Listed, File E302370, Guide WHTY

cULus to CSA Standard 22.2 No. 4, File E302370, Guide WHTY7

CE Compliant

Shipping Weight: 2.03 lbs per carton

Carton quantity: 6 poles

Environmental Data

Storage and operating temperature: -20°C to 75°C**

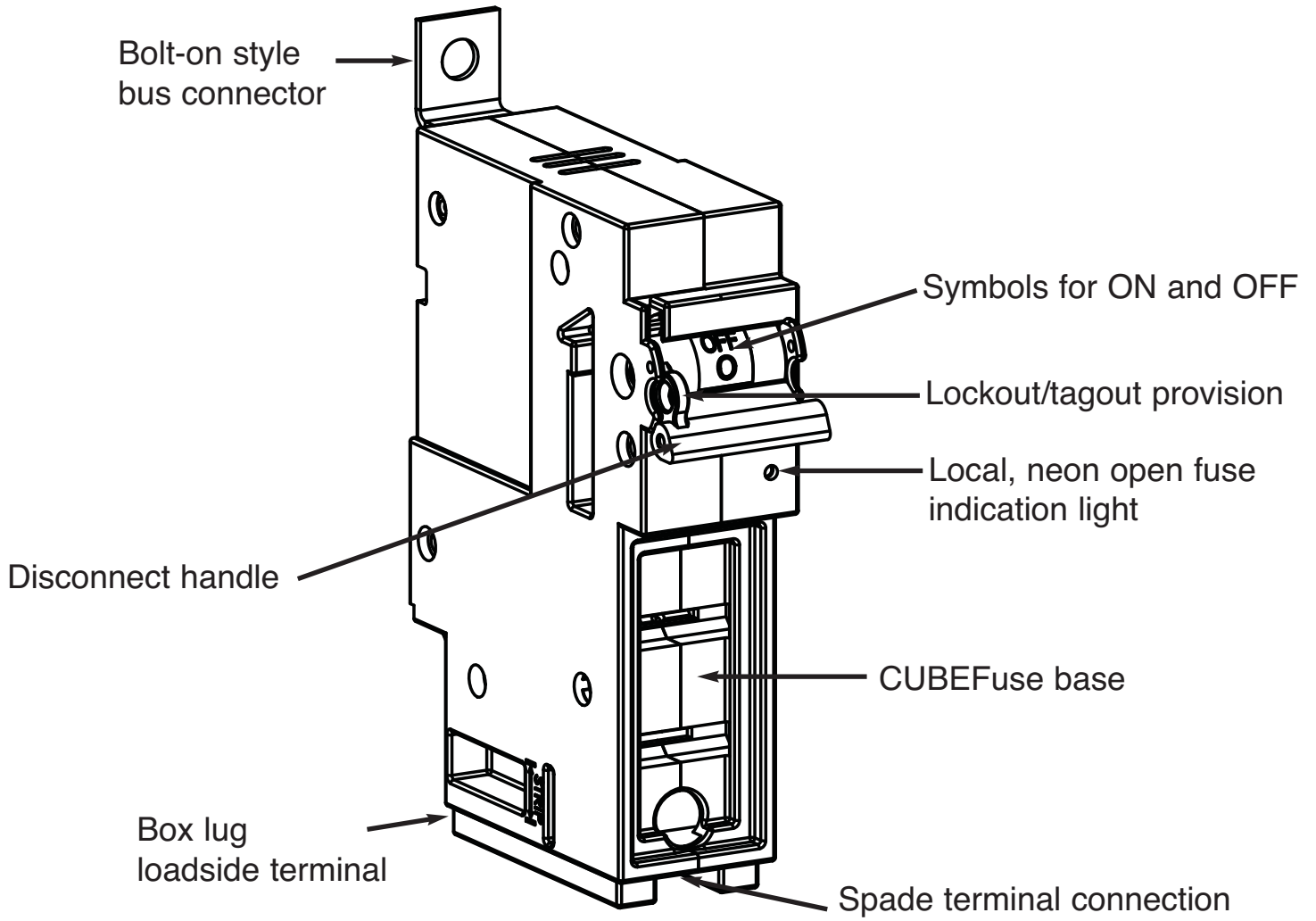

Technical Ratings

CCPB Part Numbers	Poles	Voltage Rating	CUBEFuse (Class J performance)			Max. Fuse** Ampacity	SCCR	Hp Ratings***
			Time-Delay Non-Indicating	Time-Delay Indicating*	Fast-Acting Non-Indicating			
CCPB-1-15CF	1	600Vac	TCF1RN, TCF3RN, TCF6RN, TCF10RN, TCF15RN	TCF6, TCF10, TCF15	FCF1RN, FCF3RN, FCF6RN, FCF10RN, FCF15RN	15A	200kA	0.5Hp@120V
CCPB-2-15CF	2							1.5Hp@240V
CCPB-3-15CF	3							3Hp@240V 5Hp@480V 7.5Hp@600V
CCPB-1-20CF	1	600Vac	TCF17-1/2RN, TCF20RN	TCF17-1/2, TCF20	FCF20RN	20A	200kA	0.75Hp@120V
CCPB-2-20CF	2							2Hp@240V
CCPB-3-20CF	3							3Hp@240V 7.5Hp@480V 10Hp@600V
CCPB-1-30CF	1	600Vac	TCF25RN, TCF30RN	TCF25, TCF30	FCF25RN, FCF30RN	30A	200kA	1.5Hp@120V
CCPB-2-30CF	2							3Hp@240V
CCPB-3-30CF	3							5Hp@240V 15Hp@480V 10Hp@600V
CCPB-1-40CF	1	600Vac	TCF35RN, TCF40RN	TCF35, TCF40	FCF35RN, FCF40RN	40A	200kA	2.0Hp@120V
CCPB-2-40CF	2							3Hp@240V
CCPB-3-40CF	3							7.5Hp@240V 20Hp@480V 10Hp@600V
CCPB-1-50CF	1	600Vac	TCF45RN, TCF50RN	TCF45, TCF50	FCF45RN, FCF50RN	50A	200kA	3.0Hp@120V
CCPB-2-50CF	2							5Hp@240V
CCPB-3-50CF	3							7.5Hp@240V 20Hp@480V 10Hp@600V
CCPB-1-60CF	1	600Vac	TCF60RN	TCF60	FCF60RN	60A	200kA	3.0Hp@120V
CCPB-2-60CF	2							7.5Hp@240V
CCPB-3-60CF	3							7.5Hp@240V 20Hp@480V 10Hp@600V
CCPB-1-70CF	1	600Vac	TCF70RN	TCF70	FCF70RN	70A	200kA	3.0Hp@120V
CCPB-2-70CF	2							7.5Hp@240V
CCPB-3-70CF	3							15Hp@240V 30Hp@480V
CCPB-1-90CF	1	600Vac	TCF90RN	TCF90	FCF80RN, FCF90RN	90A	200kA	5.0Hp@120V
CCPB-2-90CF	2							10Hp@240V
CCPB-3-90CF	3							20Hp@240V 40Hp@480V
CCPB-1-100CF	1	600Vac	TCF100RN	TCF100	FCF100RN	100A	200kA	5.0Hp@120V
CCPB-2-100CF	2							10Hp@240V
CCPB-3-100CF	3							20Hp@240V 50Hp@480V

*1A and 3A indicating CUBEFuse not available. Correct fit with CCPB disconnect requires indicating CUBEFuse with date code R38 or later.

**Any fuse with an amp rating less than or equal to the max fuse rating may be used. Example: TCF15 may be used with CCPB-1-20CF.

***Do not use UPS/Critical Application fast-acting CF with motors.

CUBEFuse Motor Sizing Table

Voltage	Motor Size (Hp)	Motor* FLA (Amps)	Low-Peak CUBEFuse (Amp Rating)		
			Optimal Protection	Code Max	Heavy Start
115Vac, 1-Phase	0.167	4.4	10	10	10
	0.25	5.8	10	15	15
	0.333	7.2	15	15	15
	0.5	9.8	15	20	20
	0.75	13.8	25	25	30
	1	16	25	30	35
	1.5	20	30	35	45
	2	24	40	45	50
	3	34	50	60	N/A
5**	56	90	100	N/A	
230Vac, 1-Phase	0.167	2.2	6	6	6
	0.25	2.9	6	6	6
	0.333	3.6	6	10	10
	0.5	4.9	10	10	10
	0.75	6.9	15	15	15
	1	8	15	15	17.5
	1.5	10	15	20	20
	2	12	20	25	25
	3	17	25	30	35
	5	28	45	50	60
	7.5	40	60	N/A	N/A
	10**	50	80	90	N/A
200Vac, 3-Phase	0.5	2.5	6	6	6
	0.75	3.7	6	10	10
	1	4.8	10	10	10
	1.5	6.9	15	15	15
	2	7.8	15	15	17.5
	3	11	17.5	20	20
	5	17.5	30	35	35
	7.5	25.3	40	45	50
	20**	62.1	100	N/A	N/A
208Vac, 3-Phase	0.5	2.4	6	6	6
	0.75	3.5	6	10	10
	1	4.6	10	10	10
	1.5	6.6	10	15	15
	2	7.5	15	15	15
	3	10.6	17.5	20	20
	5	16.7	25	30	35
	7.5	24.2	40	45	50
20**	59.4	90	N/A	N/A	

Voltage	Motor Size (Hp)	Motor ¹ FLA (Amps)	Low-Peak CUBEFuse (Amp Rating)		
			Optimal Protection	Code Max	Heavy Start
230Vac, 3-Phase	0.5	2.2	6	6	6
	0.75	3.2	6	6	6
	1	4.2	10	10	10
	1.5	6	10	15	15
	2	6.8	15	15	15
	3	9.6	15	20	20
	5	15.2	25	30	30
	7.5	22	35	40	45
	20**	54	90	100	N/A
460Vac, 3-Phase	0.5	1.1	3	3	3
	0.75	1.6	3	3	3
	1	2.1	6	6	6
	1.5	3	6	6	6
	2	3.4	6	6	6
	3	4.8	10	10	10
	5	7.6	15	15	15
	7.5	11	17.5	20	20
	10	14	25	25	30
	15	21	35	40	45
	20	27	40	50	60
	50**	65	100	N/A	N/A
575Vac, 3-Phase	0.5	0.9	3	3	3
	0.75	1.3	3	3	3
	1	1.7	3	3	3
	1.5	2.4	6	6	6
	2	2.7	6	6	6
	3	3.9	6	10	10
	5	6.1	10	15	15
	7.5	9	15	20	20
	10	11	17.5	20	20
	50**	52	80	100	N/A

Note: Use Code Max column for low to moderate reverse/jog/plug applications. Heavy Start permitted only if Code Max does not allow motor start-up.

*Based on motor FLA from NEC® tables 430.248 and 430.250.

**Max. Hp rating for the CCPB 100 Amp device at specified voltage.

Dimensional Data — in (mm)

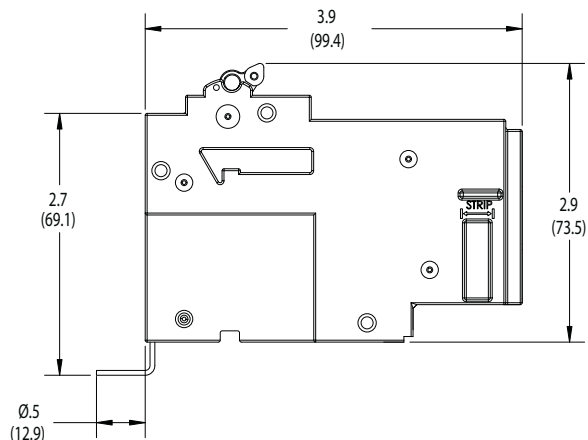
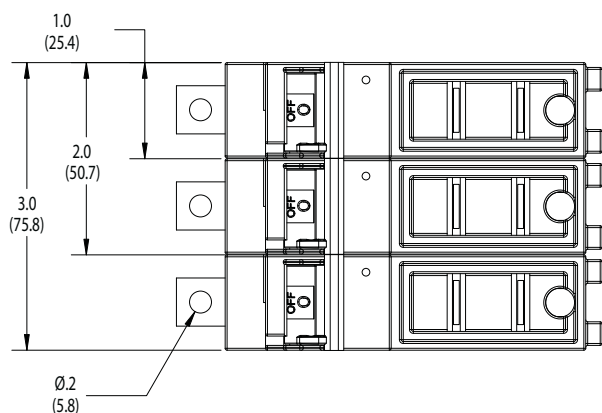

For details on the CCPB and its use in the Quik-Spec™ Coordination Panelboard, see data sheet 1160.

The only controlled copy of this Data Sheet is the electronic read-only version located on the Cooper Bussmann Network Drive. All other copies of this document are by definition uncontrolled. This bulletin is intended to clearly present comprehensive product data and provide technical information that will help the end user with design applications. Cooper Bussmann reserves the right, without notice, to change design or construction of any products and to discontinue or limit distribution of any products. Cooper Bussmann also reserves the right to change or update, without notice, any technical information contained in this bulletin. Once a product has been selected, it should be tested by the user in all possible applications.