

SLEEVE OPENING

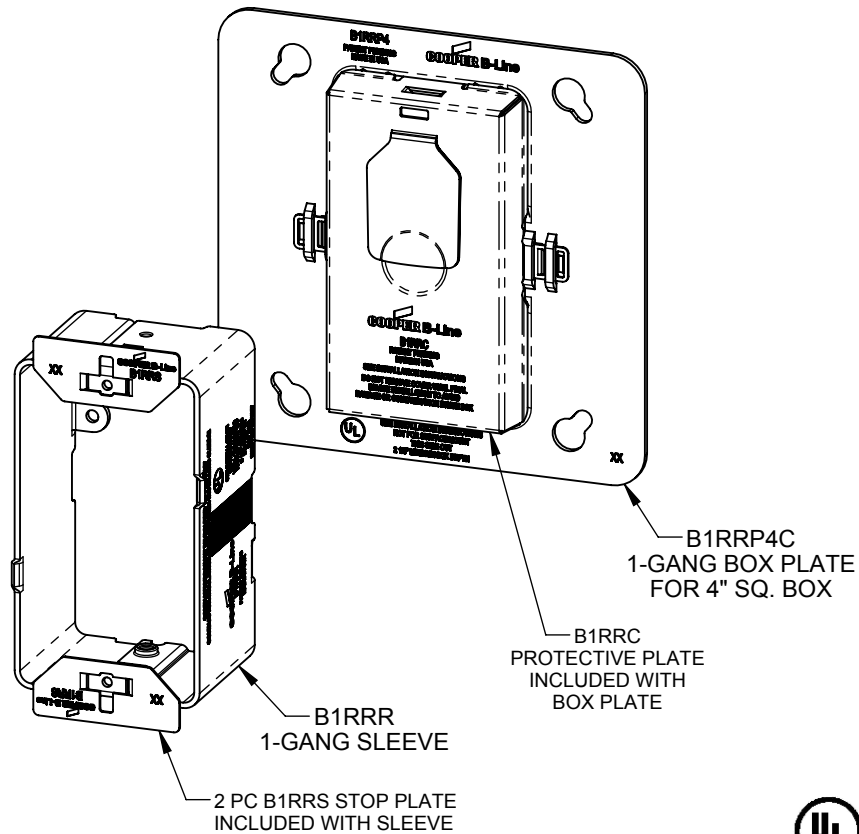

- FOR USE WITH 4" SQ. X 2 1/8" (MIN.) DEEP ELECTRICAL BOX.
- WALL THICKNESS RANGE: 1/2" - 1 1/4".
- USE OPTIONAL SLEEVE EXTENDER B1RRE FOR WALLS THICKER THAN 1 1/4" AND UP TO 2" THICK (SOLD SEPARATELY, REF. S00017038)
- SNAP-IN PROTECTIVE PLATE PROVIDES GUIDE FOR DRYWALL ROUTER AND PROTECTS INTERIOR OF ELECTRICAL BOX FROM DAMAGE AND DEBRIS DURING WALL FINISHING

THIS DRAWING AND/OR THE TECHNICAL INFORMATION CONTAINED HEREON IS THE PROPERTY OF COOPER B-LINE, INC. ("B-LINE"), AND IS ISSUED IN CONFIDENCE FOR B-LINE ENGINEERING PURPOSES ONLY AND MAY NOT BE REPRODUCED OR USED FOR ANY PURPOSE WHATSOEVER WITHOUT THE EXPRESS WRITTEN PERMISSION OF B-LINE TO THE USER. THIS DRAWING AND/OR TECHNICAL INFORMATION IS THE PROPERTY OF B-LINE AND IS LOANED FOR MUTUAL ASSISTANCE. TO BE RETURNED WHEN ITS INTENDED PURPOSE HAS BEEN SERVED.

| | | | | |
|--|---|--|--|---|
| <p>509 W. Monroe Street Highland, IL 62249 Phone (618) 654-2184 FAX (618) 654-5499 www.cooperbline.com</p> | SUBMITTAL DRAWING | | REFERENCE DWG(S): S00017038 | SUBMITTAL NO: S00017040A |
| | TITLE: RAPID RING KIT 1-GANG, 4" SQ BOX B1RR4 | | | DRAWN BY: MLW REV. A DATE: 06/01/11 |
| | | | MODEL SOURCE FILE: 00017040 REV: 00 | SHEET: 1 OF 1 |
| | <small>EQUIPMENT FURNISHED HAS BEEN FABRICATED IN ACCORDANCE WITH THIS DRAWING.</small> | | | |

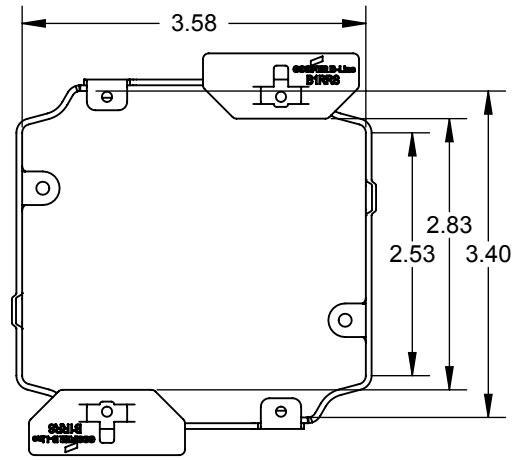

SLEEVE OPENING

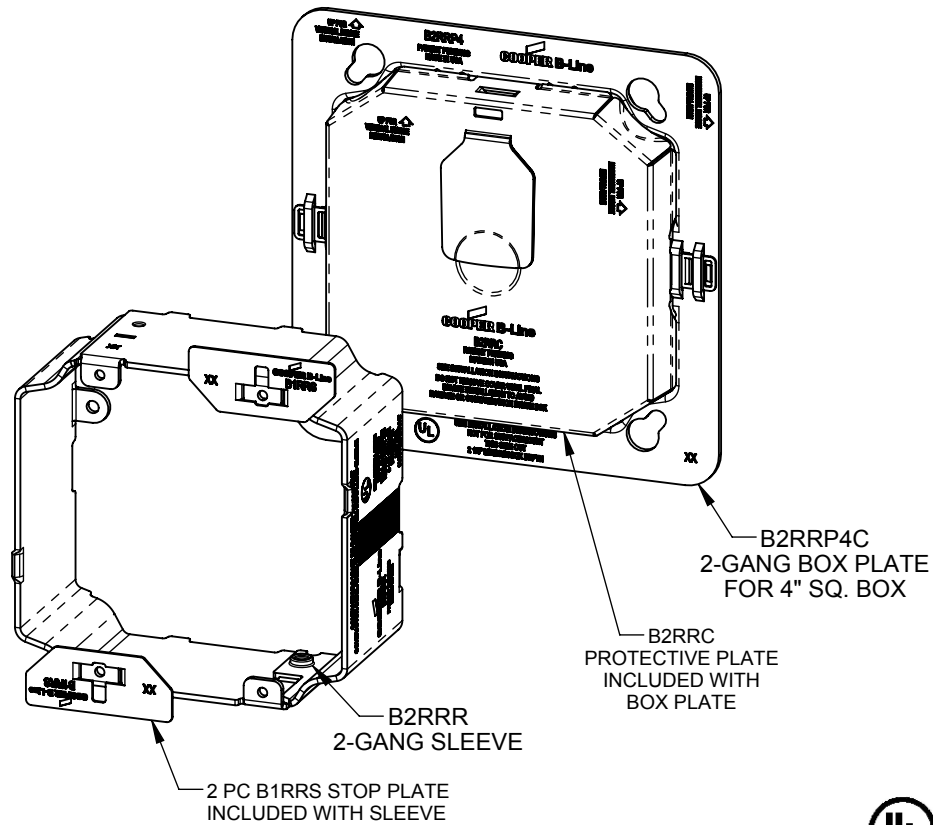

- FOR USE WITH 4" SQ. X 2 1/8" (MIN.) DEEP ELECTRICAL BOX.
- WALL THICKNESS RANGE: 1/2" - 1 1/4".
- USE OPTIONAL SLEEVE EXTENDER B2RRE FOR WALLS THICKER THAN 1 1/4" AND UP TO 2" THICK (SOLD SEPARATELY, REF. S00017038)
- SNAP-IN PROTECTIVE PLATE PROVIDES GUIDE FOR DRYWALL ROUTER AND PROTECTS INTERIOR OF ELECTRICAL BOX FROM DAMAGE AND DEBRIS DURING WALL FINISHING

THIS DRAWING AND/OR THE TECHNICAL INFORMATION CONTAINED HEREON IS THE PROPERTY OF COOPER B-LINE, INC. ("B-LINE"), AND IS ISSUED IN CONFIDENCE FOR B-LINE ENGINEERING PURPOSES ONLY AND MAY NOT BE REPRODUCED OR USED FOR ANY PURPOSE WHATSOEVER WITHOUT THE EXPRESS WRITTEN PERMISSION OF B-LINE TO THE USER. THIS DRAWING AND/OR TECHNICAL INFORMATION IS THE PROPERTY OF B-LINE AND IS LOANED FOR MUTUAL ASSISTANCE. TO BE RETURNED WHEN ITS INTENDED PURPOSE HAS BEEN SERVED.

| | | | | | |
|--|---|--|-----------------------------|-------------------|---|
| <p>509 W. Monroe Street Highland, IL 62249 Phone (618) 654-2184 FAX (618) 654-5499 www.cooperbline.com</p> | SUBMITTAL DRAWING | | REFERENCE DWG(S): | SUBMITTAL NO: | |
| | TITLE: RAPID RING KIT 2-GANG, 4" SQ BOX B2RR4 | | S00017038 | S00017040B | |
| | | | MODEL SOURCE FILE: 00017040 | REV: 00 | DRAWN BY: MLW REV: A DATE: 06/01/11 |
| | <small>EQUIPMENT FURNISHED HAS BEEN FABRICATED IN ACCORDANCE WITH THIS DRAWING.</small> | | | | SHEET: 1 OF 1 |

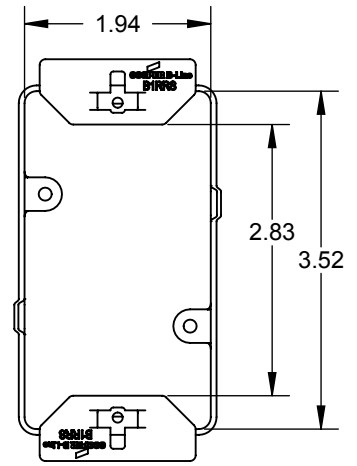

SLEEVE OPENING

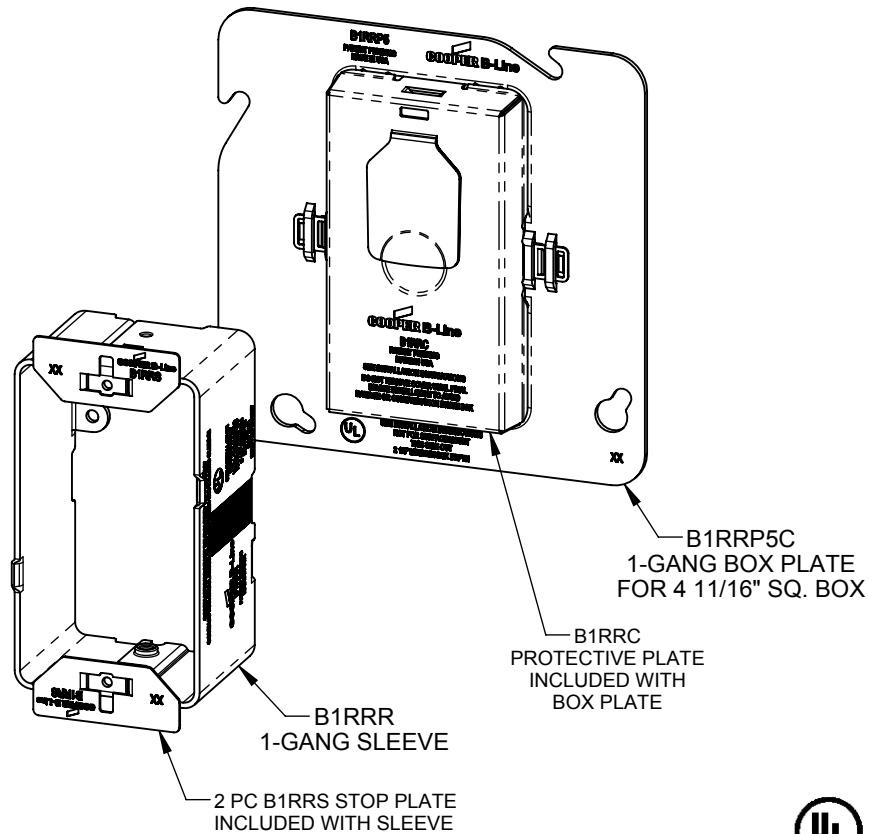

- FOR USE WITH 4 11/16" SQ. X 2 1/8" (MIN.) DEEP ELECTRICAL BOX.
- WALL THICKNESS RANGE: 1/2" - 1 1/4".
- USE OPTIONAL SLEEVE EXTENDER B1RRE FOR WALLS THICKER THAN 1 1/4" AND UP TO 2" THICK (SOLD SEPARATELY, REF. S00017038)
- SNAP-IN PROTECTIVE PLATE PROVIDES GUIDE FOR DRYWALL ROUTER AND PROTECTS INTERIOR OF ELECTRICAL BOX FROM DAMAGE AND DEBRIS DURING WALL FINISHING

THIS DRAWING AND/OR THE TECHNICAL INFORMATION CONTAINED HEREON IS THE PROPERTY OF COOPER B-LINE, INC. ("B-LINE"), AND IS ISSUED IN CONFIDENCE FOR B-LINE ENGINEERING PURPOSES ONLY AND MAY NOT BE REPRODUCED OR USED FOR ANY PURPOSE WHATSOEVER WITHOUT THE EXPRESS WRITTEN PERMISSION OF B-LINE TO THE USER. THIS DRAWING AND/OR TECHNICAL INFORMATION IS THE PROPERTY OF B-LINE AND IS LOANED FOR MUTUAL ASSISTANCE. TO BE RETURNED WHEN ITS INTENDED PURPOSE HAS BEEN SERVED.

| | | | | | |
|--|---|--|--------------------|-------------------|------------------|
| <p>509 W. Monroe Street Highland, IL 62249 Phone (618) 654-2184 FAX (618) 654-5499 www.cooperbline.com</p> | SUBMITTAL DRAWING | | REFERENCE DWG(S): | SUBMITTAL NO: | |
| | TITLE: RAPID RING KIT 1-GANG, 4 11/16" SQ BOX B1RR5 | | S00017038 | S00017040C | |
| | | | MODEL SOURCE FILE: | REV: | DRAWN BY: REV. |
| | | | 00017040 | 00 | MLW A |
| | | | | DATE: 06/01/11 | |
| | | | | SHEET: 1 OF 1 | |
| <small>EQUIPMENT FURNISHED HAS BEEN FABRICATED IN ACCORDANCE WITH THIS DRAWING.</small> | | | | | |

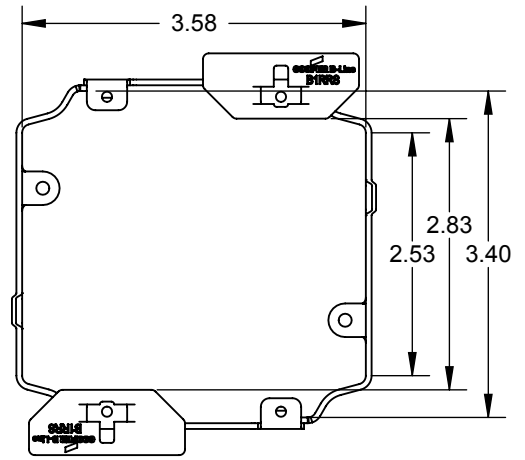

SLEEVE OPENING

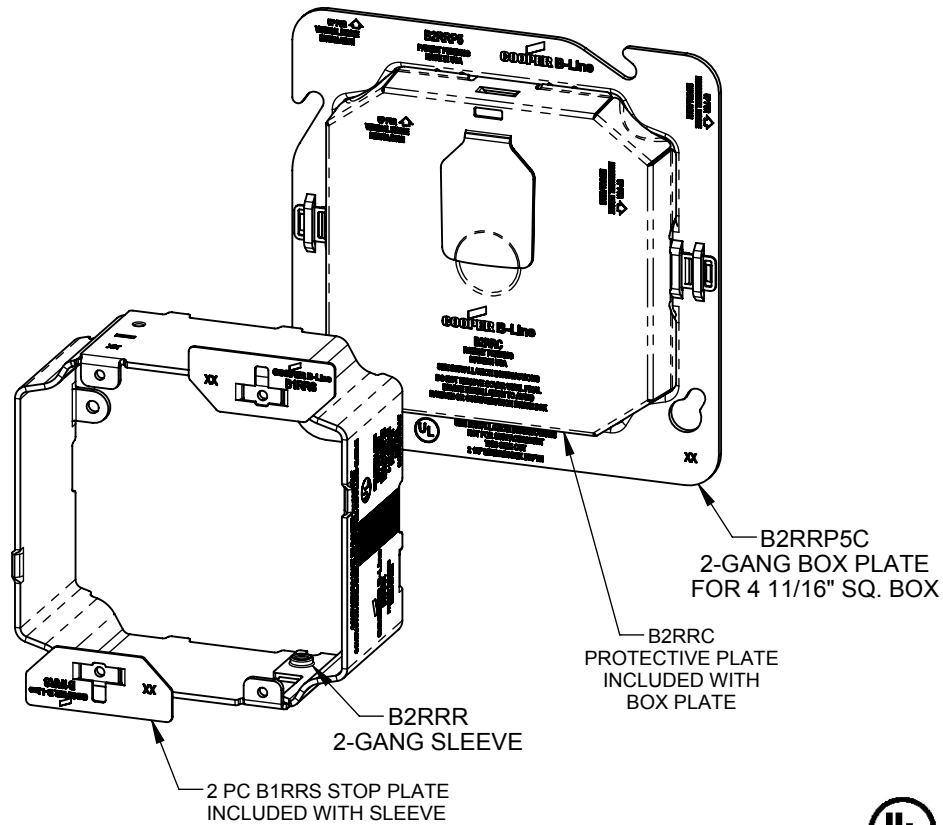

- FOR USE WITH 4 11/16" SQ. X 2 1/8" (MIN.) DEEP ELECTRICAL BOX.
- WALL THICKNESS RANGE: 1/2" - 1 1/4".
- USE OPTIONAL SLEEVE EXTENDER B2RRE FOR WALLS THICKER THAN 1 1/4" AND UP TO 2" THICK (SOLD SEPARATELY, REF. S00017038)
- SNAP-IN PROTECTIVE PLATE PROVIDES GUIDE FOR DRYWALL ROUTER AND PROTECTS INTERIOR OF ELECTRICAL BOX FROM DAMAGE AND DEBRIS DURING WALL FINISHING

THIS DRAWING AND/OR THE TECHNICAL INFORMATION CONTAINED HEREON IS THE PROPERTY OF COOPER B-LINE, INC. ("B-LINE"), AND IS ISSUED IN CONFIDENCE FOR B-LINE ENGINEERING PURPOSES ONLY AND MAY NOT BE REPRODUCED OR USED FOR ANY PURPOSE WHATSOEVER WITHOUT THE EXPRESS WRITTEN PERMISSION OF B-LINE TO THE USER. THIS DRAWING AND/OR TECHNICAL INFORMATION IS THE PROPERTY OF B-LINE AND IS LOANED FOR MUTUAL ASSISTANCE. TO BE RETURNED WHEN ITS INTENDED PURPOSE HAS BEEN SERVED.

| | | | | | |
|--|---|--|-----------------------------|-------------------|---|
| <p>509 W. Monroe Street Highland, IL 62249 Phone (618) 654-2184 FAX (618) 654-5499 www.cooperbline.com</p> | SUBMITTAL DRAWING | | REFERENCE DWG(S): | SUBMITTAL NO: | |
| | TITLE: RAPID RING KIT 2-GANG, 4 11/16" SQ BOX B2RR5 | | S00017038 | S00017040D | |
| | | | MODEL SOURCE FILE: 00017040 | REV: 00 | DRAWN BY: MLW REV: A DATE: 06/01/11 |
| | <small>EQUIPMENT FURNISHED HAS BEEN FABRICATED IN ACCORDANCE WITH THIS DRAWING.</small> | | | | SHEET: 1 OF 1 |

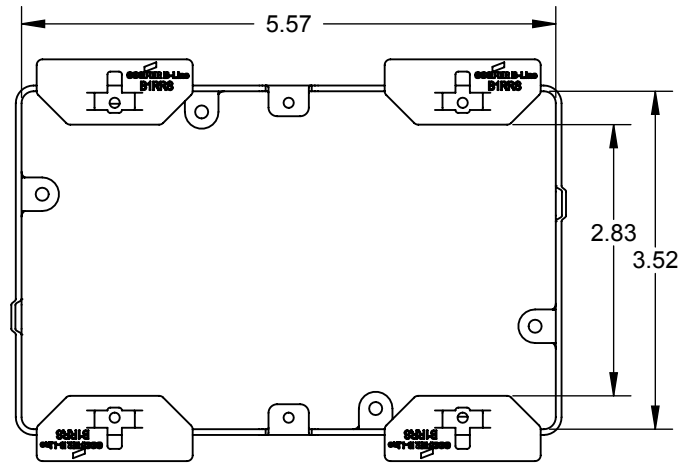

SLEEVE OPENING

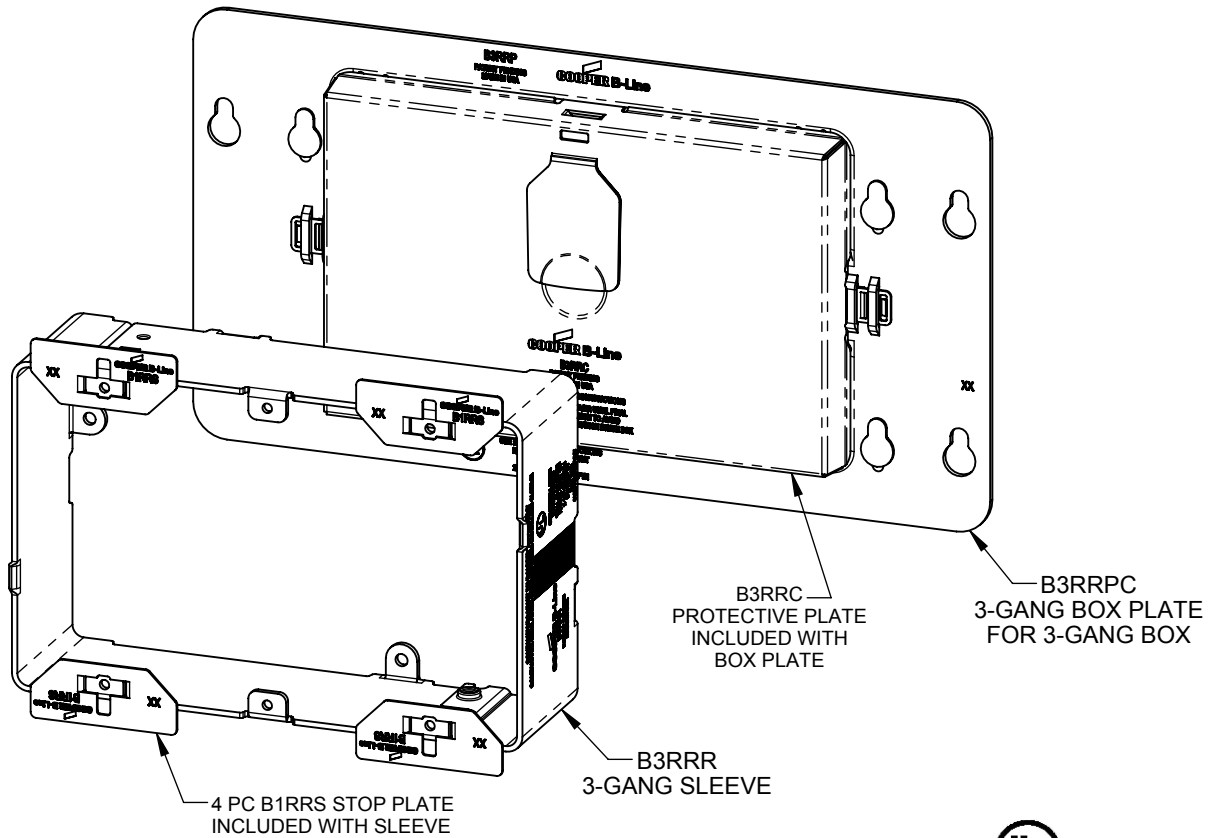

- FOR USE WITH 3-GANG X 2 1/2" (MIN.) DEEP ELECTRICAL BOX.
- KNOCK-OUTS PROVIDE OPTIONAL USE ON 2-GANG X 2 1/2" (MIN.) DEEP ELECTRICAL BOX.
- WALL THICKNESS RANGE: 1/2" - 1 1/4".
- USE OPTIONAL SLEEVE EXTENDER B3RRE FOR WALLS THICKER THAN 1 1/4" AND UP TO 2" THICK (SOLD SEPARATELY, REF. S00017038)
- SNAP-IN PROTECTIVE PLATE PROVIDES GUIDE FOR DRYWALL ROUTER AND PROTECTS INTERIOR OF ELECTRICAL BOX FROM DAMAGE AND DEBRIS DURING WALL FINISHING

THIS DRAWING AND/OR THE TECHNICAL INFORMATION CONTAINED HEREON IS THE PROPERTY OF COOPER B-LINE, INC. ("B-LINE"), AND IS ISSUED IN CONFIDENCE FOR B-LINE ENGINEERING PURPOSES ONLY AND MAY NOT BE REPRODUCED OR USED FOR ANY PURPOSE WHATSOEVER WITHOUT THE EXPRESS WRITTEN PERMISSION OF B-LINE TO THE USER. THIS DRAWING AND/OR TECHNICAL INFORMATION IS THE PROPERTY OF B-LINE AND IS LOANED FOR MUTUAL ASSISTANCE. TO BE RETURNED WHEN ITS INTENDED PURPOSE HAS BEEN SERVED.

| | | | | | |
|--|---|--|-----------------------------|-------------------|---|
| <p>509 W. Monroe Street Highland, IL 62249 Phone (618) 654-2184 FAX (618) 654-5499 www.cooperbline.com</p> | SUBMITTAL DRAWING | | REFERENCE DWG(S): | SUBMITTAL NO: | |
| | TITLE: RAPID RING KIT 3-GANG B3RR | | S00017038 | S00017040E | |
| | | | MODEL SOURCE FILE: 00017040 | REV: 00 | DRAWN BY: MLW REV: A DATE: 06/01/11 |
| | <small>EQUIPMENT FURNISHED HAS BEEN FABRICATED IN ACCORDANCE WITH THIS DRAWING.</small> | | | | SHEET: 1 OF 1 |

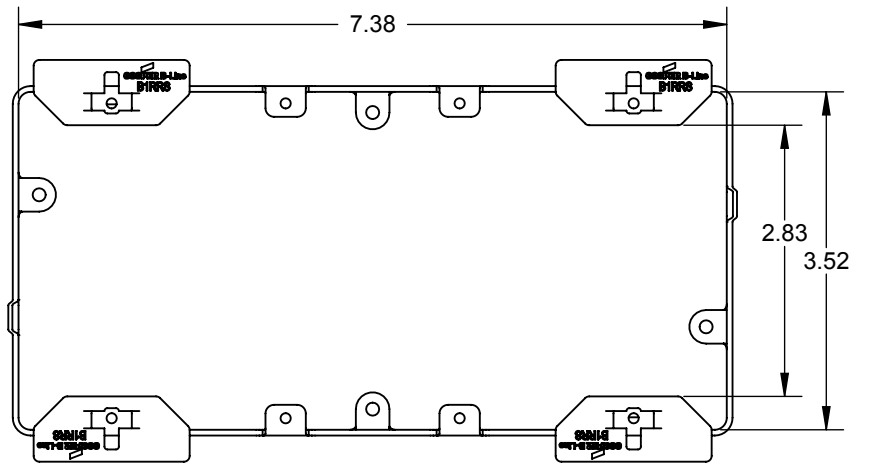

SLEEVE OPENING

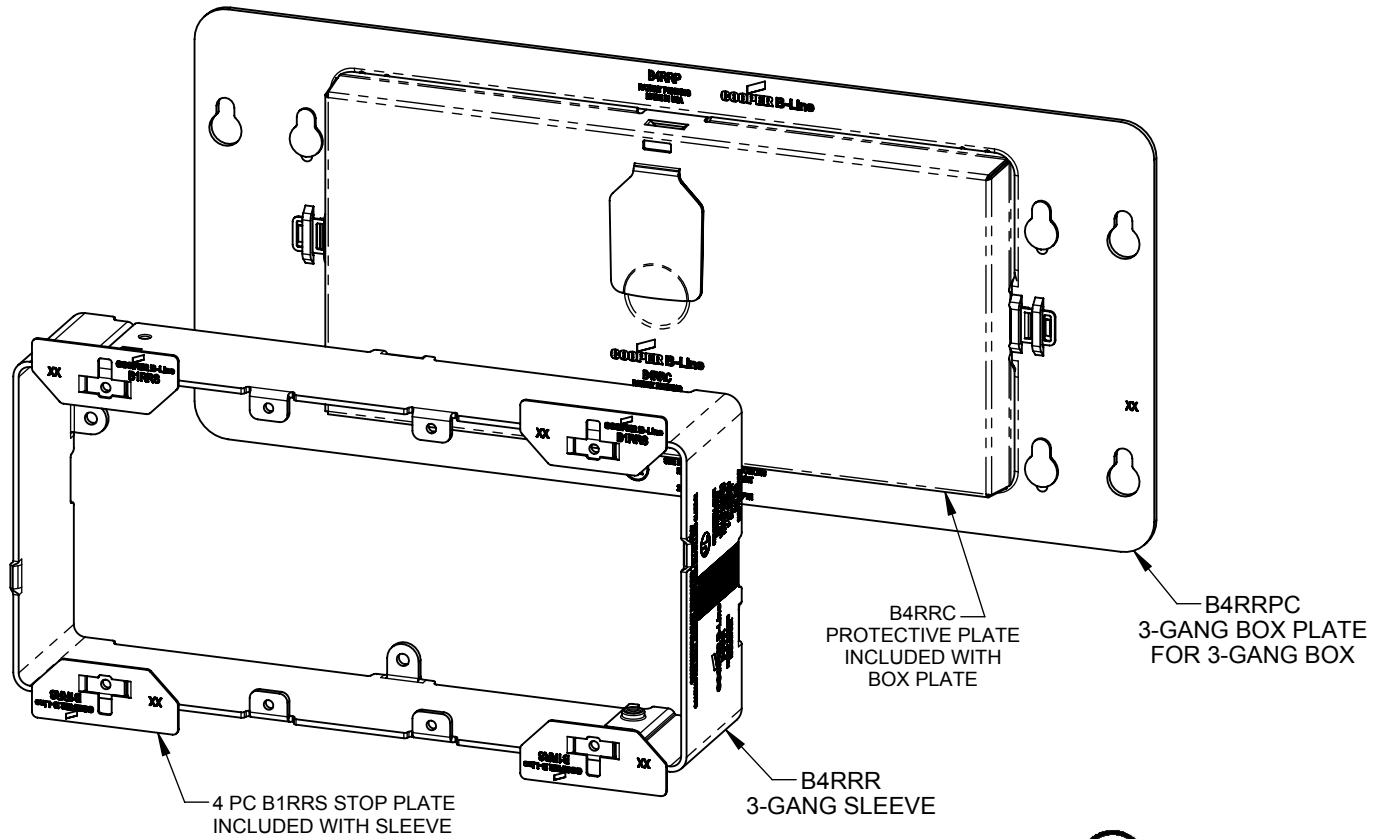

- FOR USE WITH 4-GANG X 2 1/2" (MIN.) DEEP ELECTRICAL BOX.
- KNOCK-OUTS PROVIDE OPTIONAL USE ON 3-GANG X 2 1/2" (MIN.) DEEP ELECTRICAL BOX.
- WALL THICKNESS RANGE: 1/2" - 1 1/4".
- USE OPTIONAL SLEEVE EXTENDER B4RRE FOR WALLS THICKER THAN 1 1/4" AND UP TO 2" THICK (SOLD SEPARATELY, REF. S00017038)
- SNAP-IN PROTECTIVE PLATE PROVIDES GUIDE FOR DRYWALL ROUTER AND PROTECTS INTERIOR OF ELECTRICAL BOX FROM DAMAGE AND DEBRIS DURING WALL FINISHING

THIS DRAWING AND/OR THE TECHNICAL INFORMATION CONTAINED HEREON IS THE PROPERTY OF COOPER B-LINE, INC. ("B-LINE"), AND IS ISSUED IN CONFIDENCE FOR B-LINE ENGINEERING PURPOSES ONLY AND MAY NOT BE REPRODUCED OR USED FOR ANY PURPOSE WHATSOEVER WITHOUT THE EXPRESS WRITTEN PERMISSION OF B-LINE TO THE USER. THIS DRAWING AND/OR TECHNICAL INFORMATION IS THE PROPERTY OF B-LINE AND IS LOANED FOR MUTUAL ASSISTANCE. TO BE RETURNED WHEN ITS INTENDED PURPOSE HAS BEEN SERVED.

| | | | | | |
|--|---|--|--------------------|-------------------|------------------|
| <p>509 W. Monroe Street Highland, IL 62249 Phone (618) 654-2184 FAX (618) 654-5499 www.cooperbline.com</p> | SUBMITTAL DRAWING | | REFERENCE DWG(S): | SUBMITTAL NO: | |
| | TITLE: RAPID RING KIT 4-GANG B4RR | | S00017038 | S00017040F | |
| | | | MODEL SOURCE FILE: | REV: | DRAWN BY: REV. |
| | | | 00017040 | 00 | MLW A |
| | | EQUIPMENT FURNISHED HAS BEEN FABRICATED IN ACCORDANCE WITH THIS DRAWING. | | DATE: 06/01/11 | |
| | | | | SHEET: 1 OF 1 | |

SLEEVE EXTENDER SELECTION

| STYLE | SLEEVE EXTENDER CATALOG NO. | SLEEVE CATALOG NO. | SCREW QTY |
|--------|-----------------------------|--------------------|-----------|
| 1-GANG | B1RRE | B1RRR | 2 |
| 2-GANG | B2RRE | B2RRR | 2 |
| 3-GANG | B3RRE | B3RRR | 4 |
| 4-GANG | B4RRE | B4RRR | 4 |

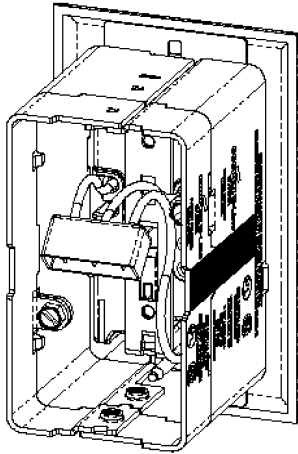

SLEEVE ASSEMBLY WITH SLEEVE EXTENDER

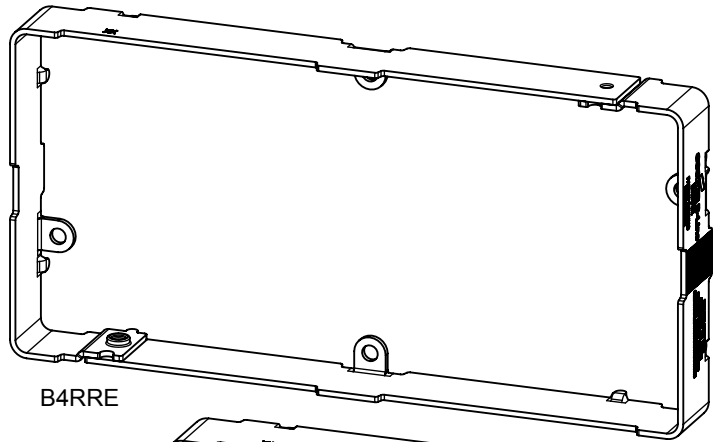

B4RRE

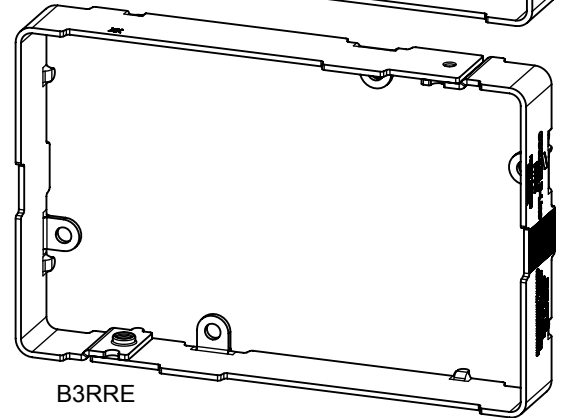

B3RRE

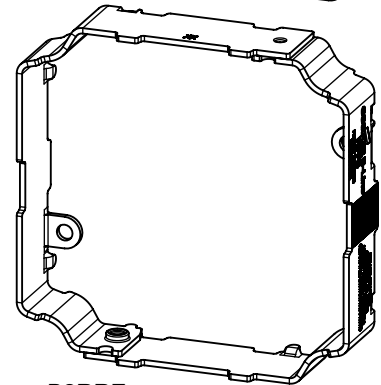

B2RRE

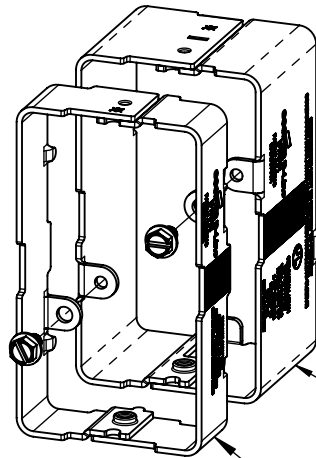

SLEEVE
B1RRR 1-GANG SHOWN

B1RRE
SLEEVE
EXTENDER



- ATTACHES TO SLEEVE FOR WALLS THICKER THAN 1 1/4" AND UP TO 2" THICK
- HARDWARE INCLUDED.
- MAY BE ADDED BEFORE OR AFTER DEVICE(S) AND TRIM PLATE ARE ASSEMBLED TO SLEEVE.

THIS DRAWING AND/OR THE TECHNICAL INFORMATION CONTAINED HEREON IS THE PROPERTY OF COOPER B-LINE, INC. ("B-LINE"), AND IS ISSUED IN CONFIDENCE FOR B-LINE ENGINEERING PURPOSES ONLY AND MAY NOT BE REPRODUCED OR USED FOR ANY PURPOSE WHATSOEVER WITHOUT THE EXPRESS WRITTEN PERMISSION OF B-LINE TO THE USER. THIS DRAWING AND/OR TECHNICAL INFORMATION IS THE PROPERTY OF B-LINE AND IS LOANED FOR MUTUAL ASSISTANCE. TO BE RETURNED WHEN ITS INTENDED PURPOSE HAS BEEN SERVED.



509 W. Monroe Street
Highland, IL 62249
Phone (618) 654-2184
FAX (618) 654-5499

www.cooperbline.com

SUBMITTAL DRAWING

TITLE:

RAPID RING
SLEEVE EXTENDER

EQUIPMENT FURNISHED HAS BEEN FABRICATED IN ACCORDANCE WITH THIS DRAWING.

REFERENCE DWG(S):

SUBMITTAL NO:

S00017038

DRAWN BY: MLW
REV: A

DATE: 06/01/11

MODEL SOURCE FILE: 00017040
REV: 00

SHEET: 1 OF 1