

-FASTENS SOLAR MODULES TO SOLAR ROOFTOP ASSEMBLY
 -TORQUE 12 FT-LBS

PRE-ASSEMBLY INCLUDES:

- 1 - EXTRUDED ALUMINUM CLAMP
- 1 - 5/16"-18 HEX HEAD CAP SCREW
- 1 - N223WO CHANNEL NUT

CATALOG NUMBER	LOAD RATING (lbs)	RANGE	SCREW
SHDMID10-31PA	-	1.0"-1.5"	5/16"-18 X 2 1/2"
SHDMID15-31PA	-	1.5"-2.0"	5/16"-18 X 3"
SHDMID20-31PA	-	2.0"-2.5"	5/16"-18 X 3 1/2"

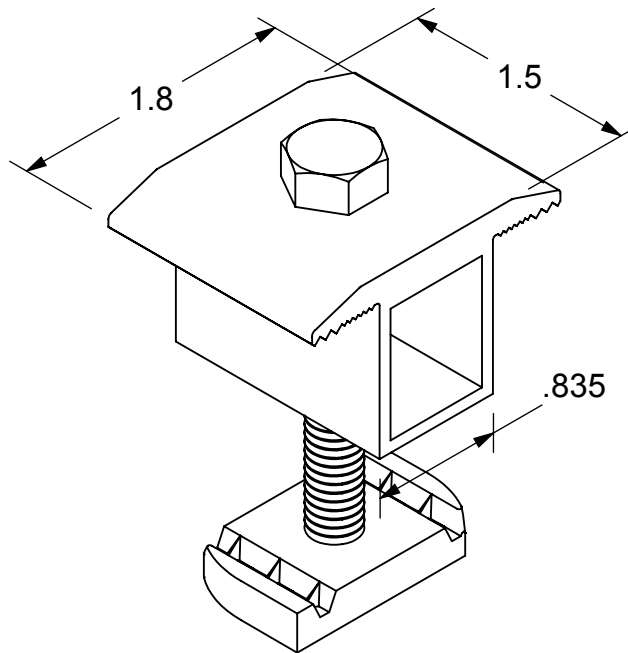
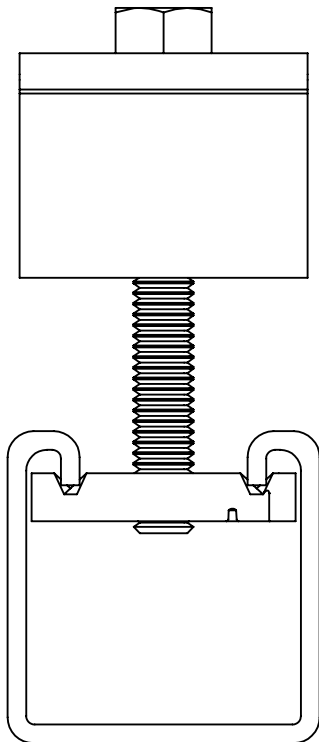

THIS DRAWING AND/OR THE TECHNICAL INFORMATION CONTAINED HEREON IS THE PROPERTY OF COOPER B-LINE, INC. ("B-LINE"), AND IS ISSUED IN CONFIDENCE FOR B-LINE ENGINEERING PURPOSES ONLY AND MAY NOT BE REPRODUCED OR USED FOR ANY PURPOSE WHATSOEVER WITHOUT THE EXPRESS WRITTEN PERMISSION OF B-LINE TO THE USER. THIS DRAWING AND/OR TECHNICAL INFORMATION IS THE PROPERTY OF B-LINE AND IS LOANED FOR MUTUAL ASSISTANCE. TO BE RETURNED WHEN ITS INTENDED PURPOSE HAS BEEN SERVED.

 509 W. Monroe Street Highland, IL 62249 Phone (618) 654-2184 FAX (618) 654-5499 www.cooperbline.com	SUBMITTAL DRAWING		REFERENCE DWG(S):	SUBMITTAL NO: S00018942	
	TITLE: SHDMIDXX-31 MID SOLAR HOLD DOWN PRE-ASSEMBLED			DRAWN BY: ERN	REV.
				DATE: 11/11/2011	
		EQUIPMENT FURNISHED HAS BEEN FABRICATED IN ACCORDANCE WITH THIS DRAWING.	MODEL SOURCE FILE: 00018942	REV: 00	SHEET: 1 OF 1

-FASTENS SOLAR MODULES TO SOLAR ROOFTOP ASSEMBLY
 -TORQUE 12 FT-LBS

PRE-ASSEMBLY INCLUDES:

- 1 - EXTRUDED ALUMINUM CLAMP
- 1 - 5/16"-18 HEX HEAD CAP SCREW
- 1 - N223WO CHANNEL NUT

CATALOG NUMBER	LOAD RATING (lbs)	RANGE	SCREW
SHDEND10-31PA	-	1.0"-1.5"	5/16"-18 X 2 1/2"
SHDEND15-31PA	-	1.5"-2.0"	5/16"-18 X 3"
SHDEND20-31PA	-	2.0"-2.5"	5/16"-18 X 3 1/2"

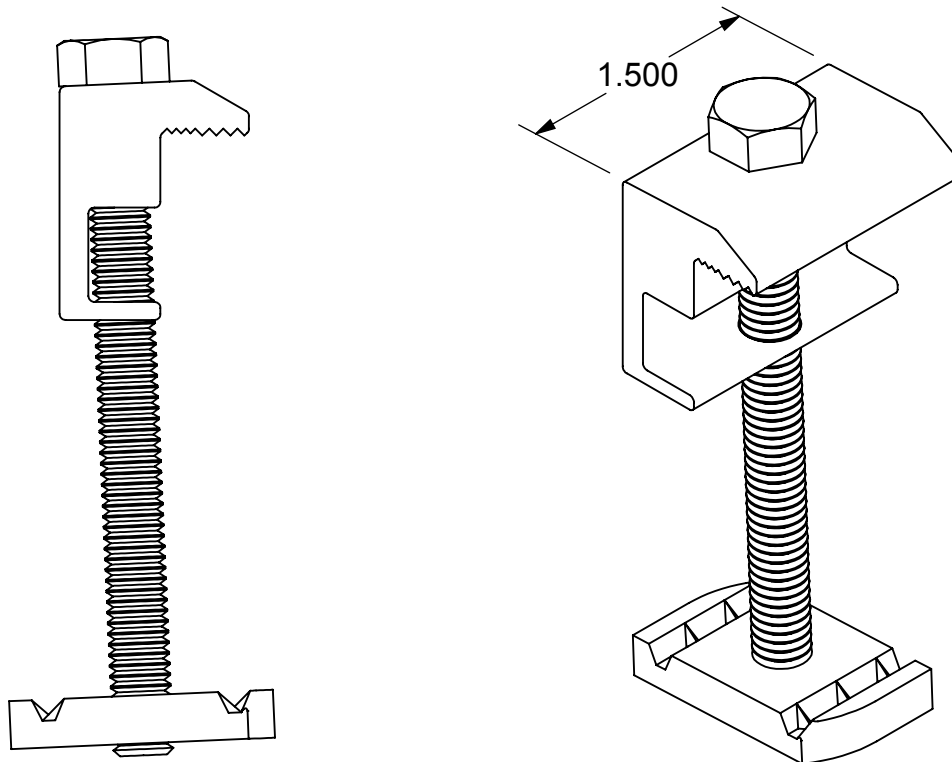

THIS DRAWING AND/OR THE TECHNICAL INFORMATION CONTAINED HEREON IS THE PROPERTY OF COOPER B-LINE, INC. ("B-LINE"), AND IS ISSUED IN CONFIDENCE FOR B-LINE ENGINEERING PURPOSES ONLY AND MAY NOT BE REPRODUCED OR USED FOR ANY PURPOSE WHATSOEVER WITHOUT THE EXPRESS WRITTEN PERMISSION OF B-LINE TO THE USER. THIS DRAWING AND/OR TECHNICAL INFORMATION IS THE PROPERTY OF B-LINE AND IS LOANED FOR MUTUAL ASSISTANCE. TO BE RETURNED WHEN ITS INTENDED PURPOSE HAS BEEN SERVED.

 509 W. Monroe Street Highland, IL 62249 Phone (618) 654-2184 FAX (618) 654-5499 www.cooperbline.com	SUBMITTAL DRAWING		REFERENCE DWG(S):	SUBMITTAL NO: S00018945	
	TITLE: SHDENDXX-31 END SOLAR HOLD DOWN PRE-ASSEMBLED			DRAWN BY: ERN	REV:
	<small>EQUIPMENT FURNISHED HAS BEEN FABRICATED IN ACCORDANCE WITH THIS DRAWING.</small>		MODEL SOURCE FILE: 00018945	REV: 00	DATE: 11/11/2011
				SHEET: 1 OF 1	

-FASTENS SOLAR MODULES TO SOLAR ROOFTOP ASSEMBLY
 -TORQUE 12 FT-LBS

PRE-ASSEMBLY INCLUDES:

- 1 - EXTRUDED ALUMINUM CLAMP
- 1 - 5/16"-18 HEX HEAD CAP SCREW
- 1 - N223WO CHANNEL NUT
- 1 - WEEB WMC BONDING WASHER

CATALOG NUMBER	LOAD RATING (lbs)	RANGE	SCREW
SHDMID10G-31PA	-	1.0"-1.5"	5/16"-18 X 2 1/2"
SHDMID15G-31PA	-	1.5"-2.0"	5/16"-18 X 3"
SHDMID20G-31PA	-	2.0"-2.5"	5/16"-18 X 3 1/2"

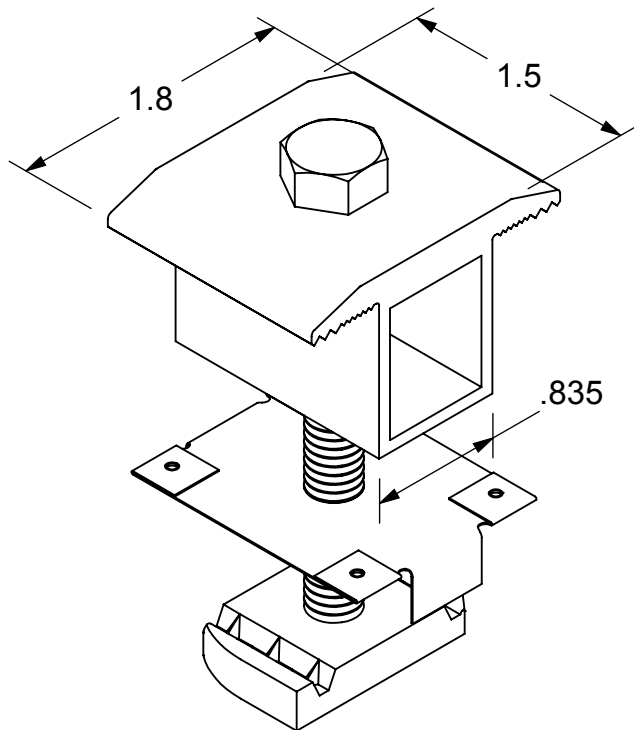
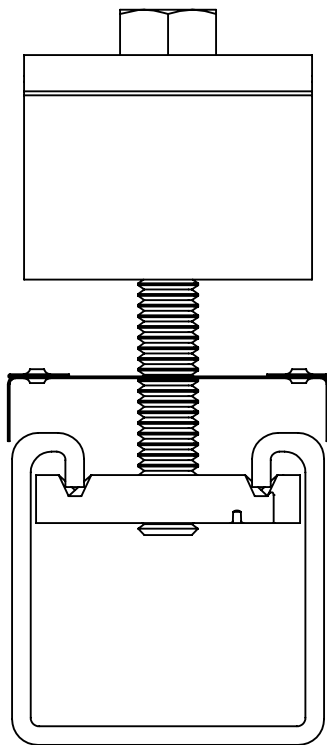

THIS DRAWING AND/OR THE TECHNICAL INFORMATION CONTAINED HEREON IS THE PROPERTY OF COOPER B-LINE, INC. ("B-LINE"), AND IS ISSUED IN CONFIDENCE FOR B-LINE ENGINEERING PURPOSES ONLY AND MAY NOT BE REPRODUCED OR USED FOR ANY PURPOSE WHATSOEVER WITHOUT THE EXPRESS WRITTEN PERMISSION OF B-LINE TO THE USER. THIS DRAWING AND/OR TECHNICAL INFORMATION IS THE PROPERTY OF B-LINE AND IS LOANED FOR MUTUAL ASSISTANCE. TO BE RETURNED WHEN ITS INTENDED PURPOSE HAS BEEN SERVED.

 509 W. Monroe Street Highland, IL 62249 Phone (618) 654-2184 FAX (618) 654-5499 www.cooperbline.com	SUBMITTAL DRAWING	REFERENCE DWG(S):	SUBMITTAL NO: S00018948
	TITLE:	SHDMIDXXG-31PA MID SOLAR HOLD DOWN PRE-ASSEMBLED WITH WEEB BONDING WASHER	DRAWN BY: ERN REV.:
	EQUIPMENT FURNISHED HAS BEEN FABRICATED IN ACCORDANCE WITH THIS DRAWING.	MODEL SOURCE FILE: 00018942 REV: 00	DATE: 11/11/2011 SHEET: 1 OF 1