

SRIS-001
Arista™ Mounting System Instruction Sheet
Solar Rooftop Support Ballasted

Tools Needed For Installation

1. 3/4" socket and wrench
2. Torque wrench
3. Tape Measure
4. Chalk Box
5. Portable saw for aluminum

Components List

1. Monolithic Base Assembly
2. Ballast Strip
3. Mounting Kit
4. Portrait Rail
5. Landscape Rail

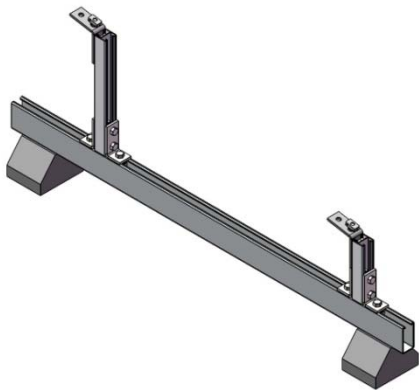

1

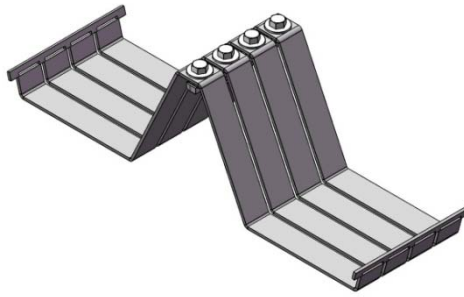

2

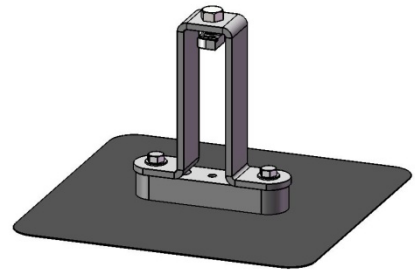

3

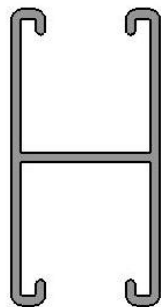

4

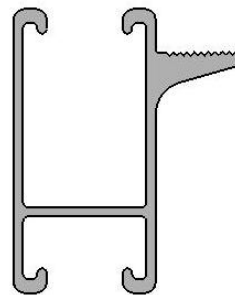

5

Before Installation

Installer is responsible for:

- Ensuring building structure is capable of supporting all required loads associated with the solar rooftop support assembly. Refer to ASCE (American Society of Civil Engineers) 7-05 for further clarification.
- Conforming to all national and local building codes that may supersede this manual.
- Ensuring that all Cooper B-Line products are suitable for the project installation requirements.
- Ensuring only Cooper B-Line products are used in installation. Any substitution of a part without written Cooper B-Line approval may void any warranty offered on Arista™ Mounting System.
- Ensuring proper installation of all electrical components related to the installed PV array.
- Ensuring all necessary load design factors are taken into account. These factors include wind speed, snow load, topographic, exposure, etc.
- Selecting appropriate flashing to ensure a watertight seal is maintained for structure.
- Selecting proper anchor/lag bolts that have appropriate pull out and shear strength ratings to ensure proper anchoring occurs.
- Ensuring proper placement of ballasts and/or positive attachments along Arista™ Mounting System.

Operation Instructions

1. Position first monolithic base assembly as not to exceed the maximum cantilever rail position as defined as 1 ft. from end of individual rails. Using a chalk box, place a chalk line to form a straight line east-west and also north-south from preferred starting corner. Next, place and connect stands along north-south chalk line. If required by panel orientation and shading distance, connect the north-south stands to each other using B172PA fittings and optional B11 that is cut to the correct length. Then, use tape measure to position base assemblies proper distance apart from one another along the east-west chalk line. Slide the B172PA fitting onto the top of the monolithic base assembly until two channel nuts are within the B11 channel. Turn the two bolt heads of the B172PA clockwise by hand until each channel nut is engaged under lips of channel. Tighten channel spring nuts to a torque of 40 ft-lbs. Repeat for the top rail.

Next, place the adjoining rails onto the remaining half of the B172PA fittings until the rails are flush with one another. Turn the loose bolt heads of the B172PA clockwise by hand until each channel nut is engaged under lips of channel. Tighten channel spring nuts to a torque of 40 ft-lbs (Make sure channel spring nut is oriented correctly under lips of channel).

Fill the array per the layout drawing.

Note: If any row or column exceeds 60 feet in any direction, replace a B172PA splice fitting with the appropriate expansion splice (per manufacturer's recommendation) at least every 60 feet to account for expansion and contraction of the racking system.

Accurate gap settings at the time of installation are necessary for the proper operation of the expansion splice. The following procedure should assist the installer in determining the correct gap (see chart 1):

1. Plot the highest expected metal temperature on the maximum temperature line.
2. Plot the lowest expected metal temperature on the minimum temperature line.
3. Draw a line between the maximum and minimum points.
4. Plot the metal temperature at the time of installation to determine the gap setting.

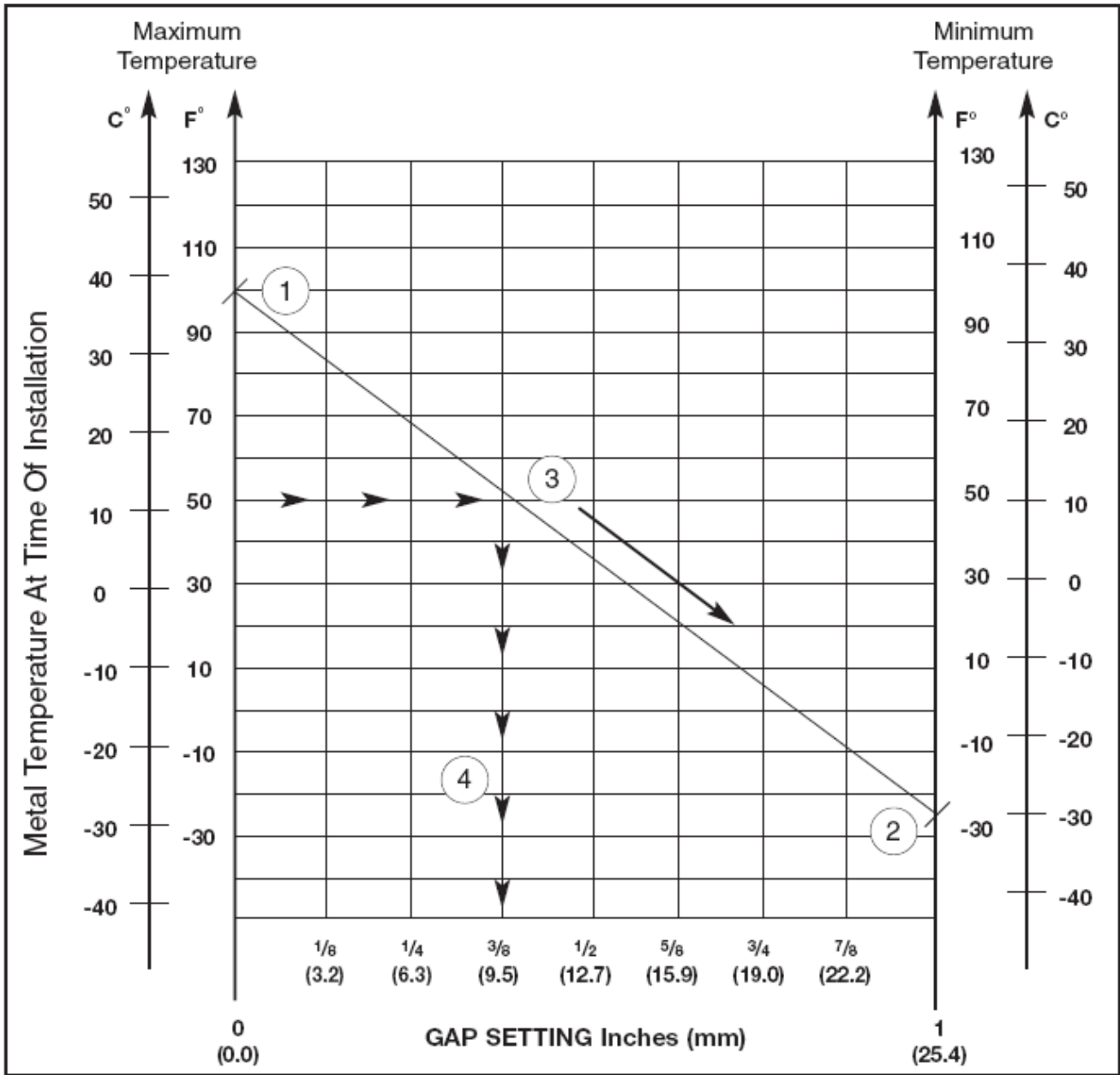
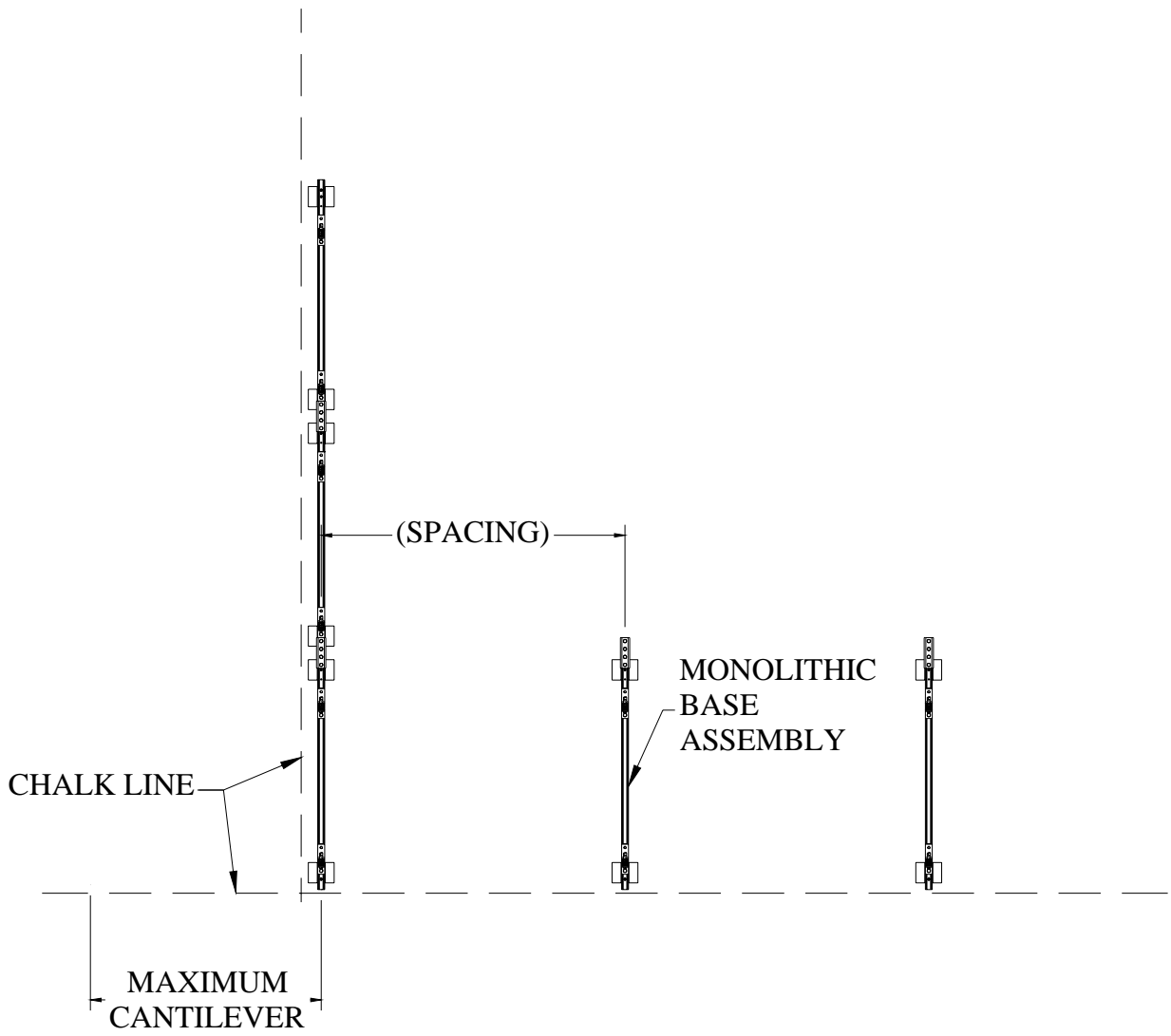
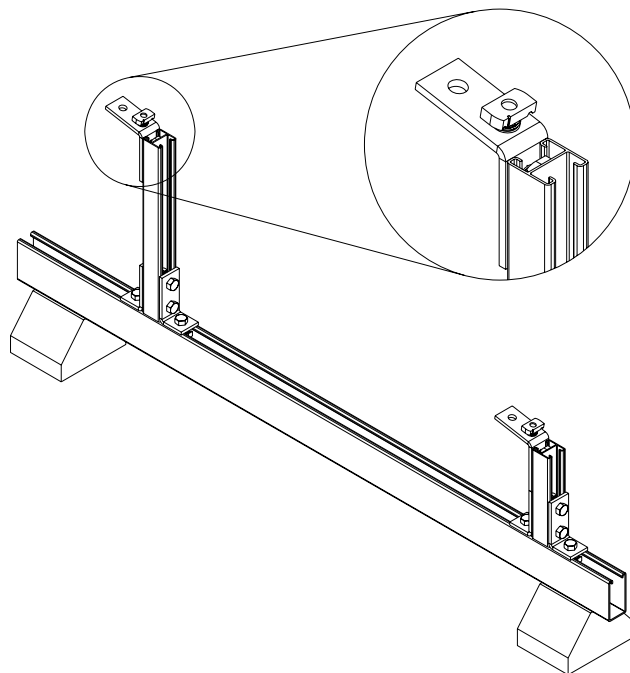

Chart 1: Expansion Splice Gap Setting



2. Correctly orient channel nuts on assemblies to allow for attachment of the rails.



A. Landscape Mount

Align landscape solar rails (2) as shown below with pre-assembled brackets attached to the top strut assembly. Position rails to where maximum cantilever is not exceeded. Ensure top and bottom rails have an equal cantilever distance. Once rails are in position resting on the pre-assembled brackets, turn the bolt heads clockwise by hand until channel nuts are engaged under lips of channel. The landscape solar rails will form parallel lines with one another. Tighten channel spring nuts to a torque of 40 ft-lbs (Make sure channel spring nut is oriented correctly under lips of channel).

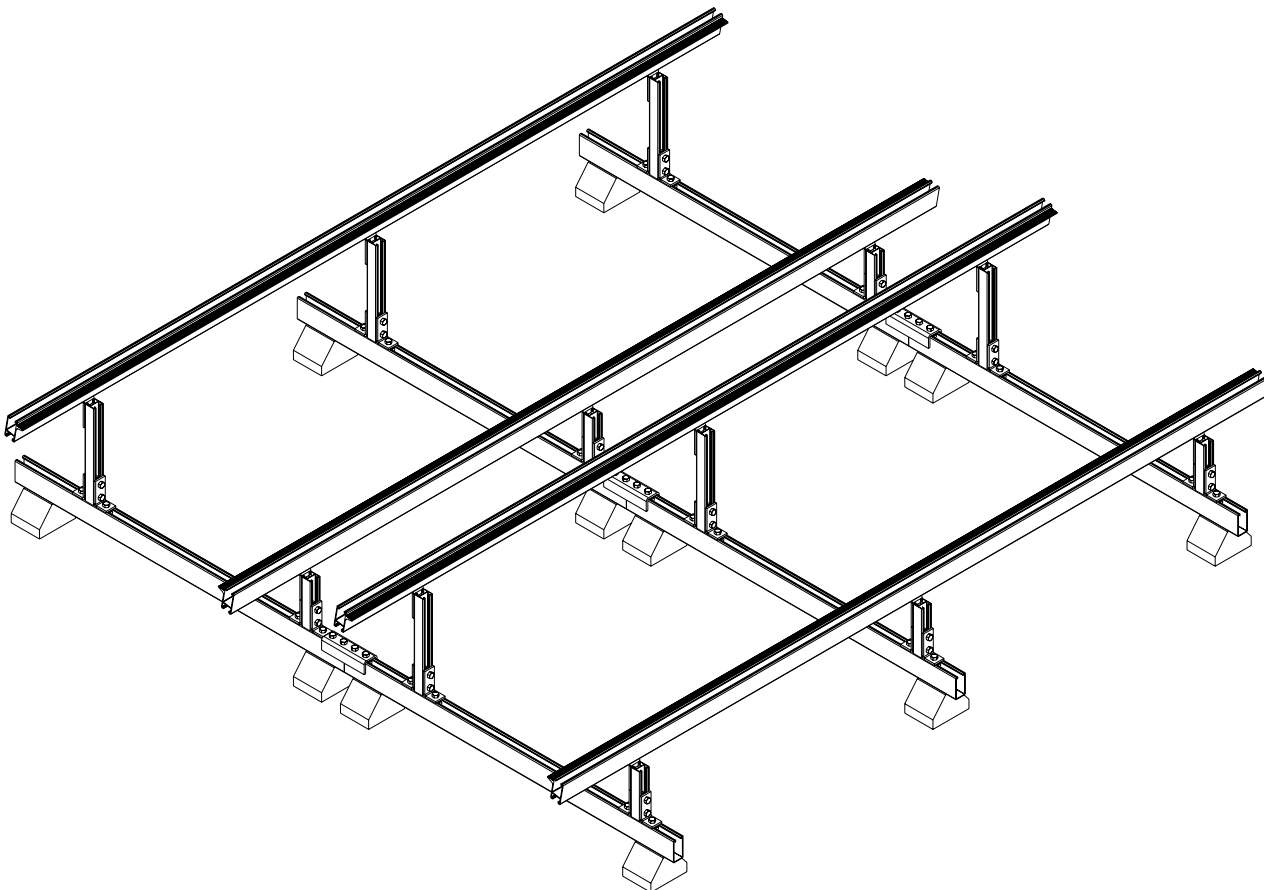
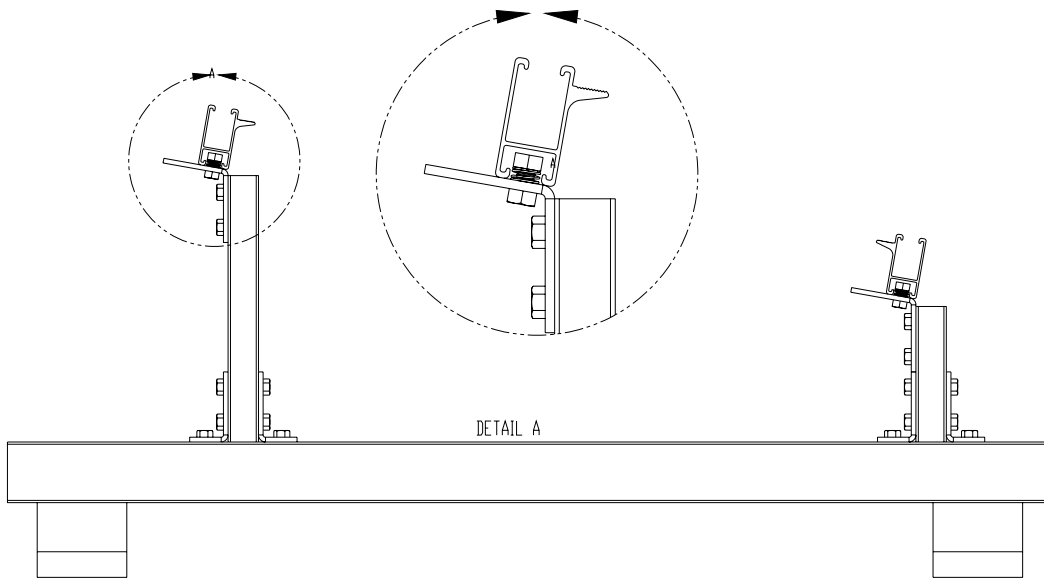

B. Portrait Mount

Align portrait B22A rails (2) as shown below with pre-assembled brackets attached to the top strut assembly. Position rails to where maximum cantilever is not exceeded. Ensure top and bottom rails have an equal cantilever distance. Once rails are in position resting on the pre-assembled brackets, turn the bolt heads clockwise by hand until channel nuts are engaged under lips of channel. The portrait B22A rails will form parallel lines with one another. Tighten channel spring nuts to a torque of 40 ft-lbs (Make sure channel spring nut is oriented correctly under lips of channel).

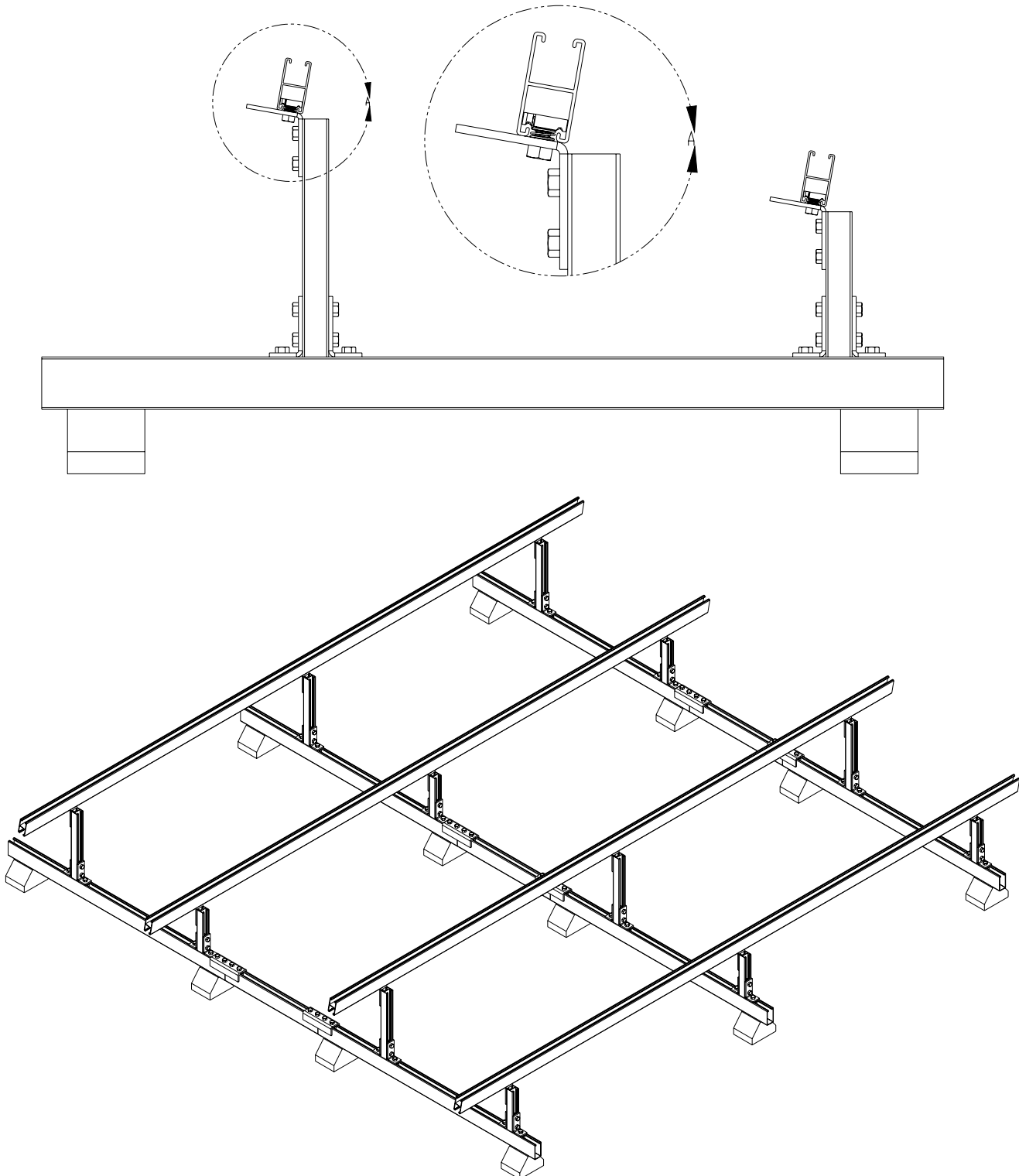

3. Install ballast strip or mounting kit onto base strut assembly as required.

A. Ballast Strip

Position a ballast strip onto the base strut assembly by aligning the channel nuts with the bottom strut. Once ballast strip is resting on base strut, turn the bolt head clockwise by hand until channel nut is engaged under lips of channel. Tighten channel spring nuts to a torque of 20-30 ft-lbs ensuring channel nuts are oriented correctly under lips of channel (see picture below). Repeat as shown on the provided layout drawings.

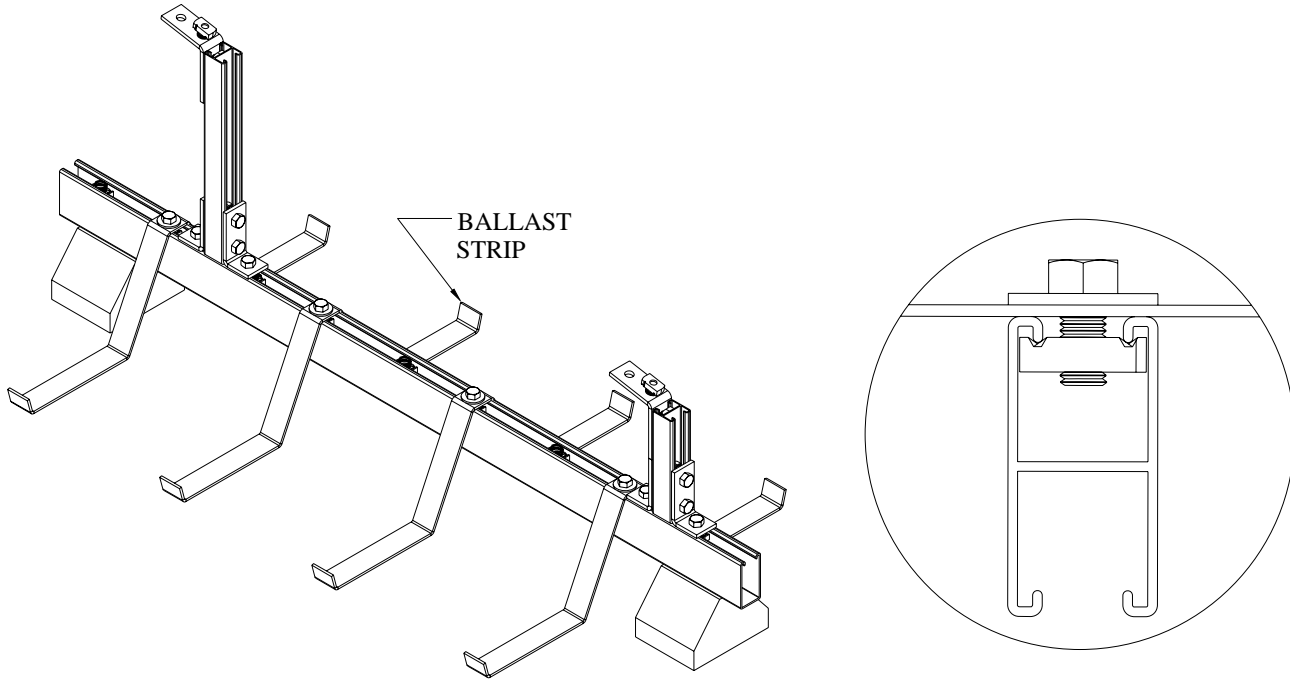

B. Mounting Kit

Position a mounting kit onto the base strut assembly by aligning the channel nut with the bottom strut. Once mounting kit is resting on base strut, turn the bolt head clockwise by hand until channel nut is engaged under lips of channel. Tighten channel spring nut to a torque of 40 ft-lbs ensuring channel nut is oriented correctly under lips of channel (see picture below). Repeat as shown on the provided layout drawings. Please refer to mounting kit installation instructions for proper attachment to building structure.

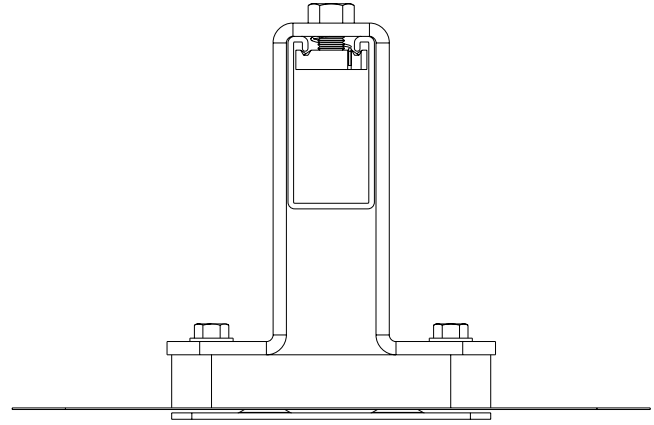
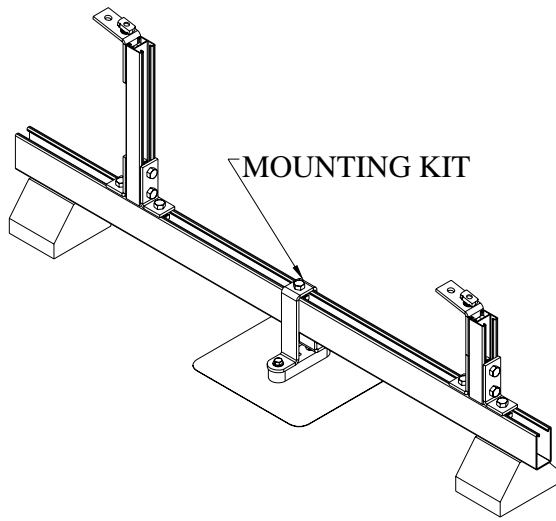

Insert equal amount of weights on both sides of ballast strips in order to meet the minimum weight requirements. Weights are based on standard 8" x 2" x 16", 16 pound concrete pavers (verify paver dimensions). Other weights can be used if minimum required weight is satisfied. Pavers are to be attached to each ballast strip and to each other with a bead line of landscape concrete paver construction grade adhesive.

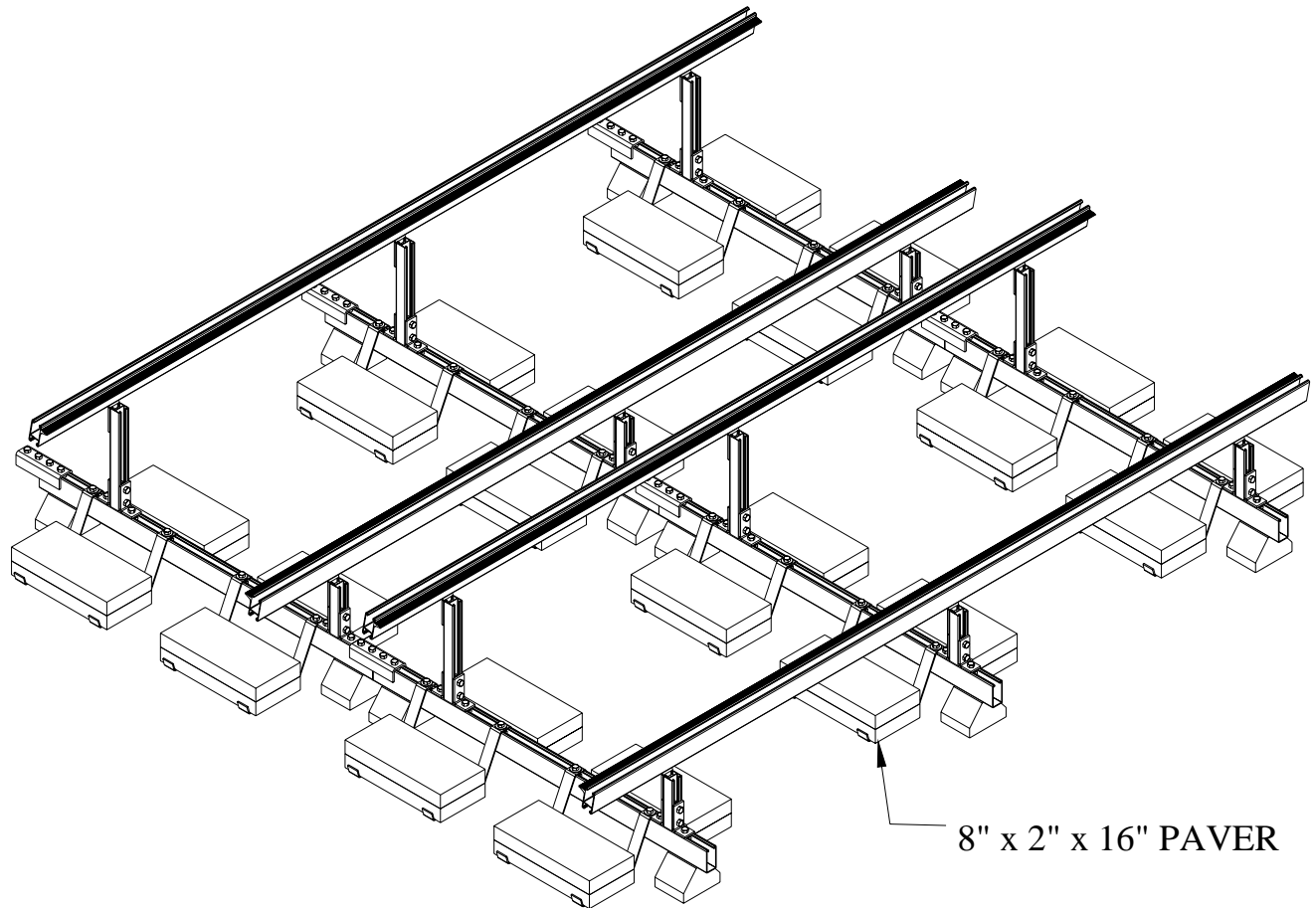

1. (OPTIONAL):

If ganging is necessary, use B172PA four hole pre-assembled splice plates to properly connect top and bottom rails of consecutive assemblies. Slide the B172PA fitting into bottom of the bottom rail until two channel nuts are within the channel. Turn the two bolt heads of the B172PA clockwise by hand until each channel nut is engaged under lips of channel. Tighten channel spring nuts to a torque of 40 ft-lbs. Repeat for the top rail.

Next, place the adjoining rails onto the remaining half of the B172PA fittings until the rails are flush with one another. Turn the loose bolt heads of the B172PA clockwise by hand until each channel nut is engaged under lips of channel. Tighten channel spring nuts to a torque of 40 ft-lbs (Make sure channel spring nut is oriented correctly under lips of channel).

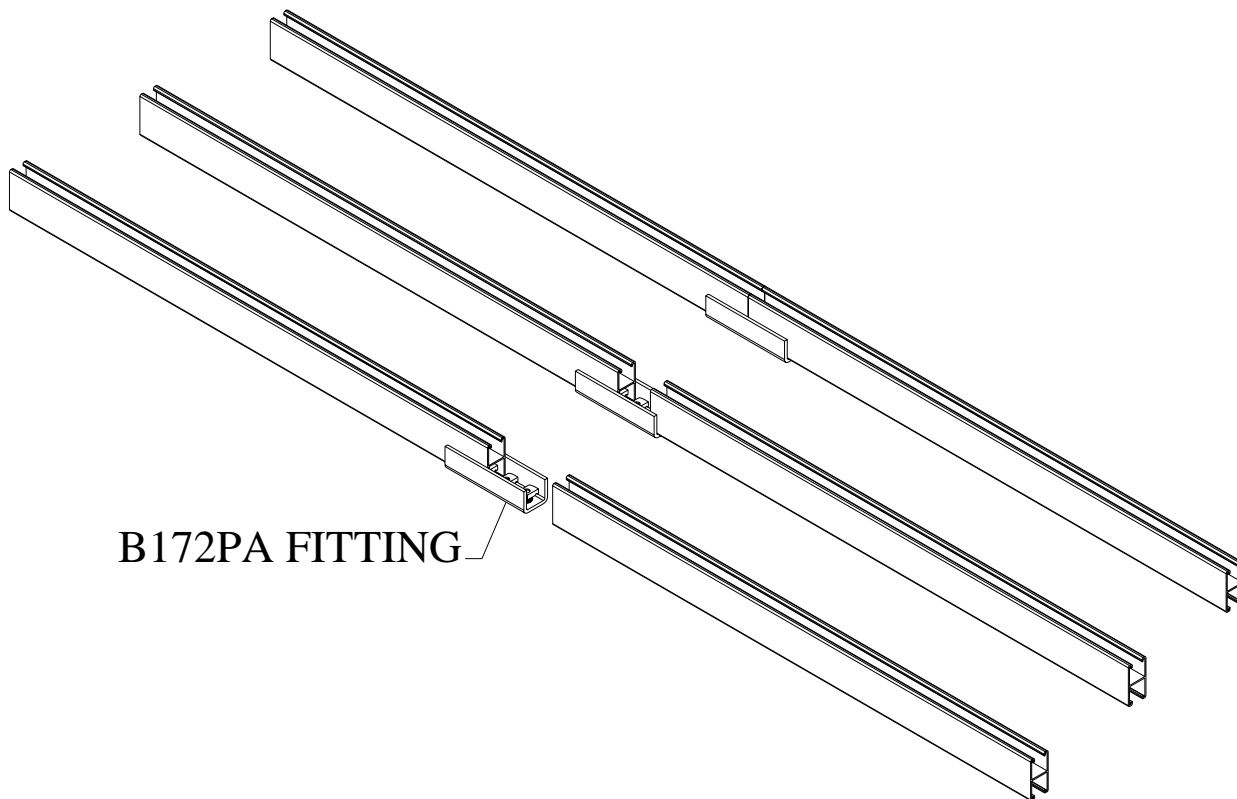

Assembly is now ready to mount PV modules.

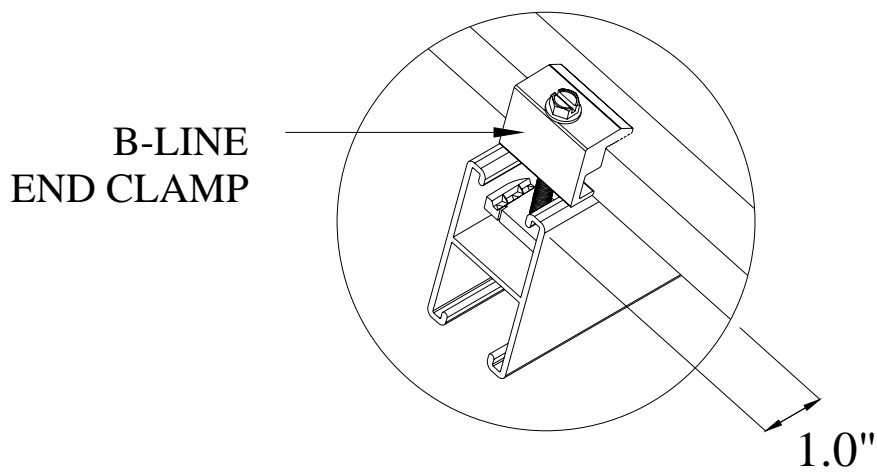

2. Insert B-Line mid clamps on each rail and press them flush against the first installed module. While clamps are loose, position the next PV module onto the mounting assembly until mid clamp is pinched between the two PV modules. Adjust PV module until top and bottom corners are in line with the previous installed module. Tighten down mid clamps to a torque of 6 ft-lbs ensuring channel nuts are oriented correctly under lips of channel.

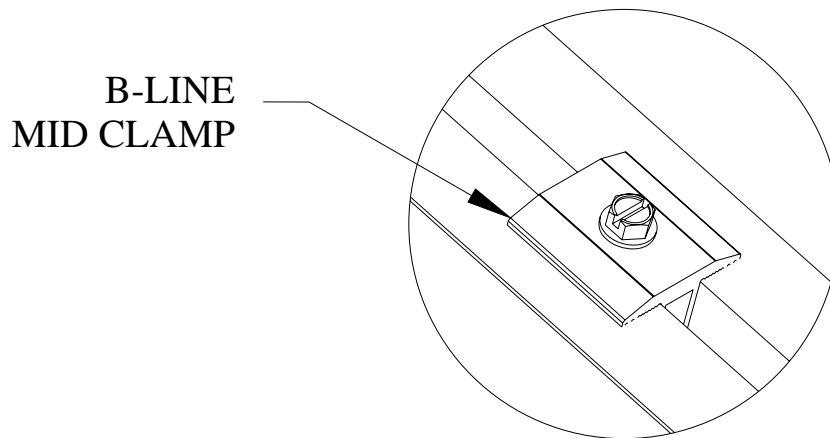

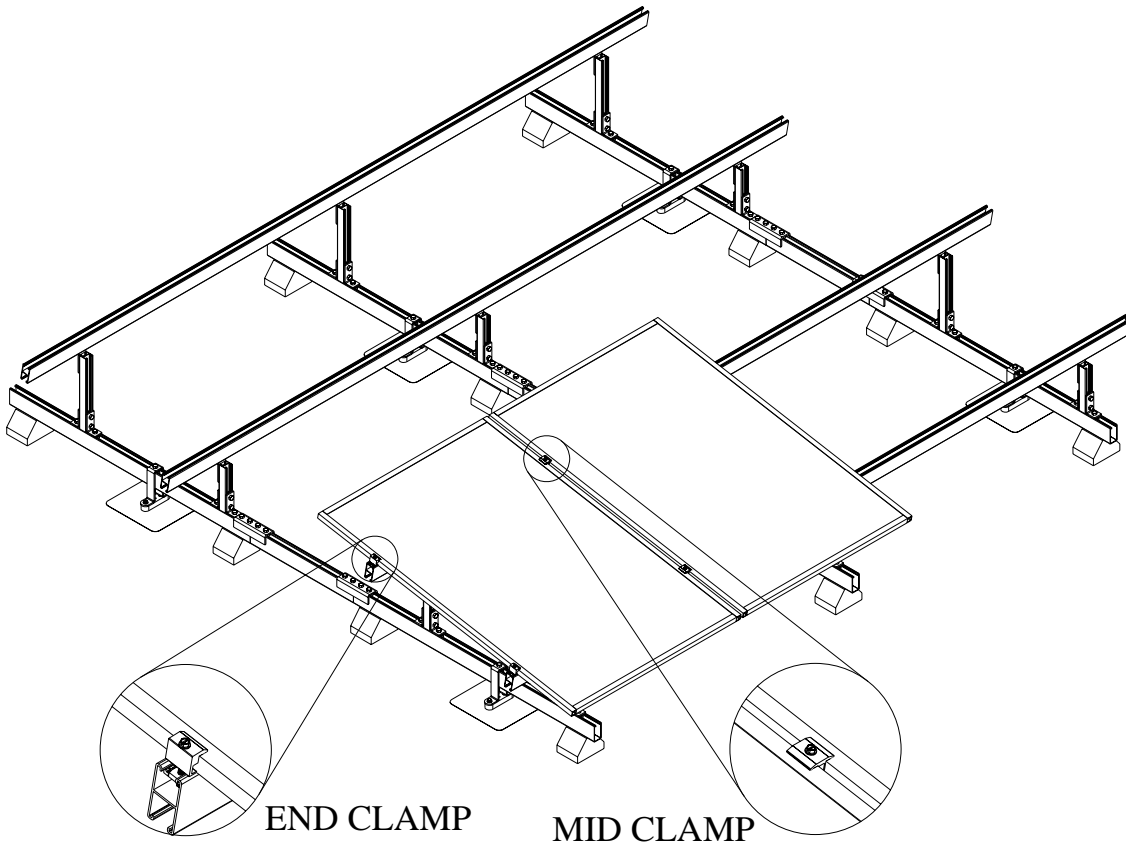

3. Repeat step 2 until all modules are in place along array.
4. Position a B-Line end clamp at the end of each rail until clamps are pressed flush against the last module frame (Ensure channel nut does not protrude outside the edge of the rails. If so, adjust modules as necessary to ensure channel nuts are positioned correctly under lip of channel). Tighten down end clamps to a torque of 6 ft-lbs.

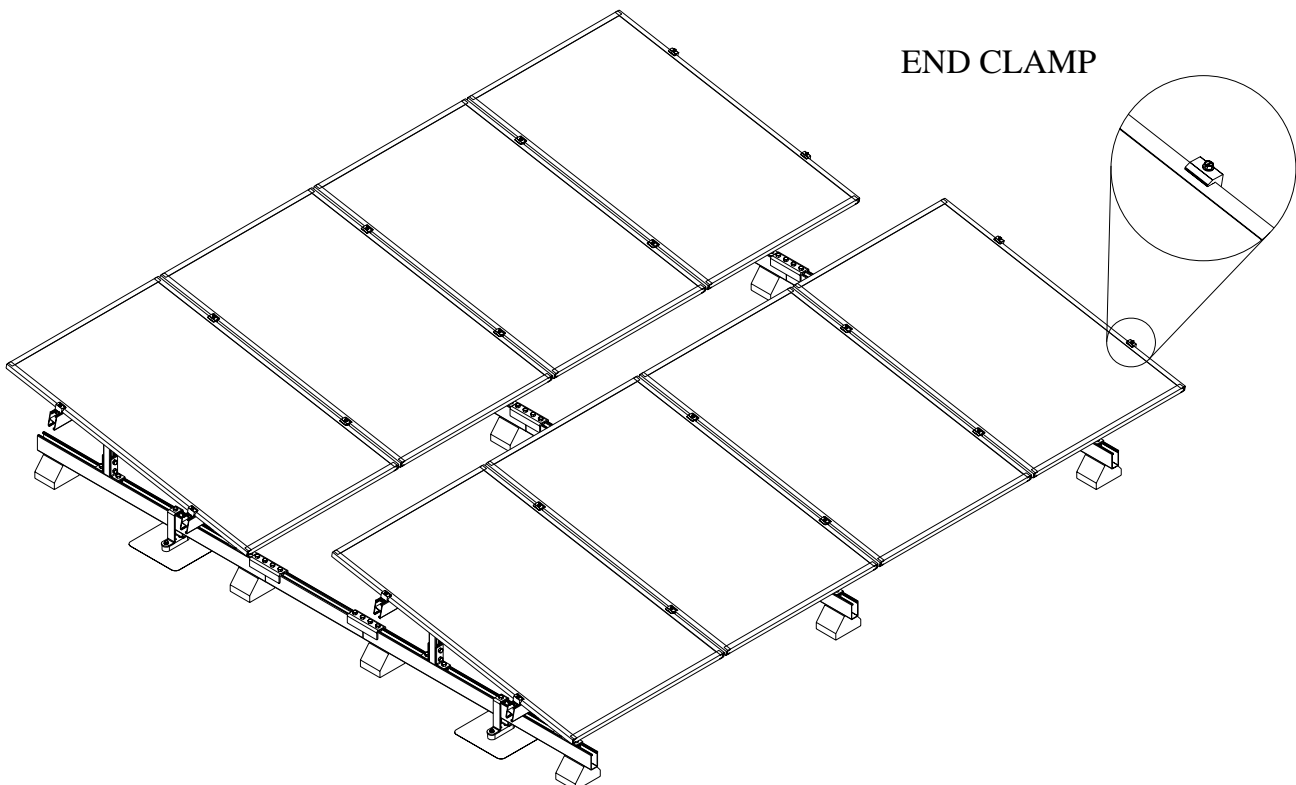

-FASTENS SOLAR MODULES TO SOLAR ROOFTOP ASSEMBLY
 -TORQUE 4 TO 6 FT-LBS

PRE-ASSEMBLY INCLUDES:

- 1 - EXTRUDED ALUMINUM CLAMP
- 1 - 1/4"-20 SLOTTED WASHER HEX HEAD CAP SCREW
- 1 - N224WO CHANNEL NUT

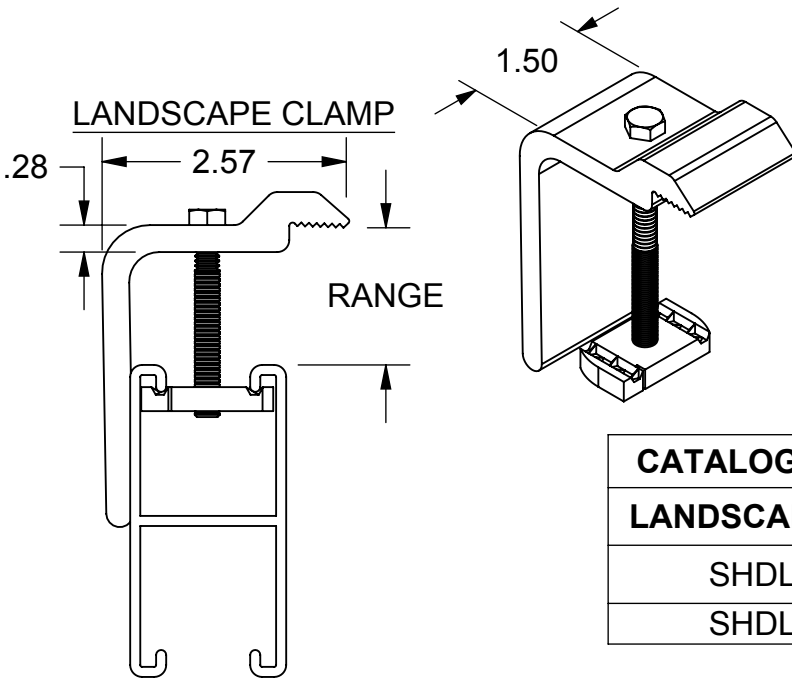

CATALOG NUMBER	LOAD RATING (lbs)	RANGE
SHDLND08	300	.75" - 1.75"
SHDLND18	300	1.75" - 2.50"

MID CLAMP

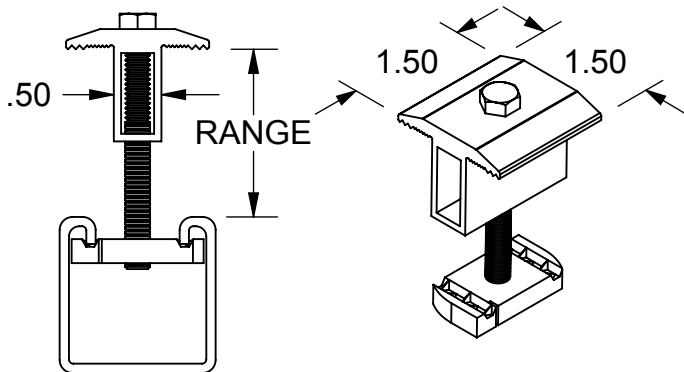

END CLAMP

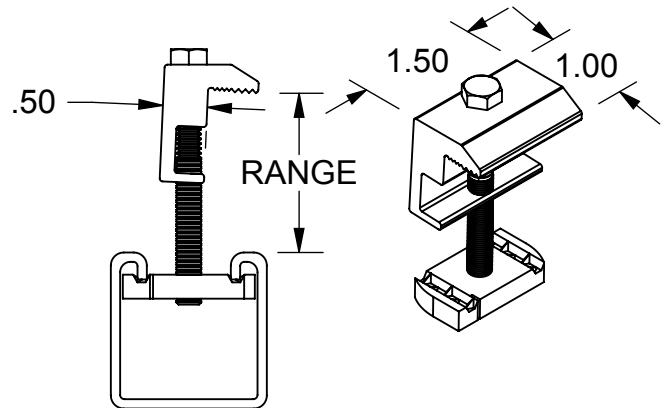

MID CLAMP		END CLAMP		RANGE
CATALOG NUMBER	LOAD RATING (lbs)	CATALOG NUMBER	LOAD RATING (lbs)	
SHDMID10	600	SHDEND10	250	1.0"-1.5"
SHDMID15	600	SHDEND15	250	1.5"-2.0"
SHDMID20	600	SHDEND20	250	2.0"-2.5"

THIS DRAWING AND/OR THE TECHNICAL INFORMATION CONTAINED HEREON IS THE PROPERTY OF COOPER B-LINE, INC. ("B-LINE"), AND IS ISSUED IN CONFIDENCE FOR B-LINE ENGINEERING PURPOSES ONLY AND MAY NOT BE REPRODUCED OR USED FOR ANY PURPOSE WHATSOEVER WITHOUT THE EXPRESS WRITTEN PERMISSION OF B-LINE TO THE USER. THIS DRAWING AND/OR TECHNICAL INFORMATION IS THE PROPERTY OF B-LINE AND IS LOANED FOR MUTUAL ASSISTANCE. TO BE RETURNED WHEN ITS INTENDED PURPOSE HAS BEEN SERVED.



509 W. Monroe Street
 Highland, IL 62249
 Phone (618) 654-2184
 FAX (618) 654-5499

www.cooperbline.com

SUBMITTAL DRAWING

TITLE:
**SOLAR MODULE HOLD DOWN
 PRE-ASSEMBLED**

REFERENCE DWG(S):

SUBMITTAL NO:
S00017106

DRAWN BY: TCS
 REV: B

DATE:
03/31/2010

MODEL SOURCE FILE: 00017106
 REV: 00

SHEET:
1 OF 1

EQUIPMENT FURNISHED HAS BEEN FABRICATED IN ACCORDANCE WITH THIS DRAWING.

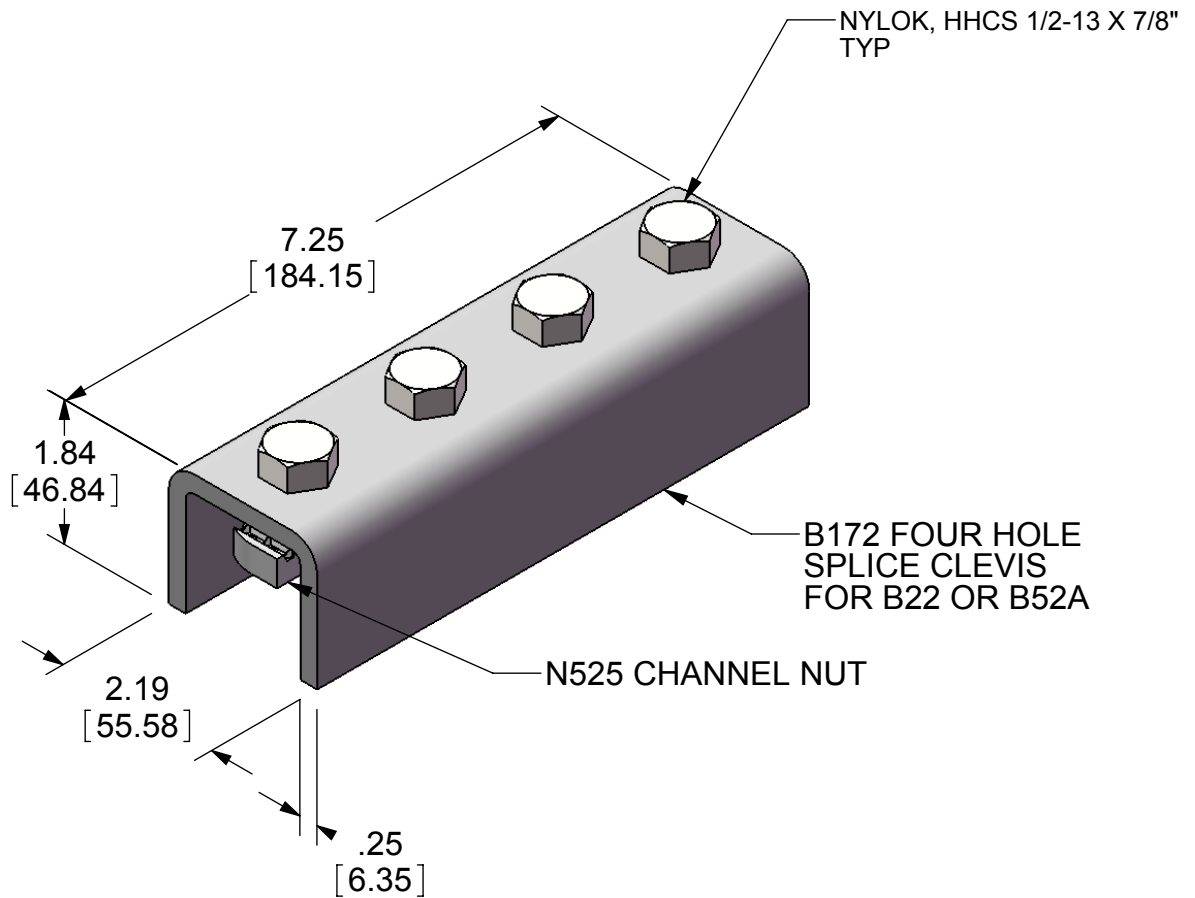

DIMENSIONS IN BRACKETS [] ARE MILLIMETERS

- BOLTS AND CHANNEL NUTS PREASSEMBLED TO FITTING FOR FASTER INSTALLATION
- FINISH: ELECTRO-PLATED
- WT/PC: 3.22 LBS [1.46 KG]

THIS DRAWING AND/OR THE TECHNICAL INFORMATION CONTAINED HEREON IS THE PROPERTY OF COOPER B-LINE, INC. ("B-LINE"), AND IS ISSUED IN CONFIDENCE FOR B-LINE ENGINEERING PURPOSES ONLY AND MAY NOT BE REPRODUCED OR USED FOR ANY PURPOSE WHATSOEVER WITHOUT THE EXPRESS WRITTEN PERMISSION OF B-LINE TO THE USER. THIS DRAWING AND/OR TECHNICAL INFORMATION IS THE PROPERTY OF B-LINE AND IS LOANED FOR MUTUAL ASSISTANCE. TO BE RETURNED WHEN ITS INTENDED PURPOSE HAS BEEN SERVED.

 <p>509 W. Monroe Street Highland, IL 62249 Phone (618) 654-2184 FAX (618) 654-5499 www.cooperbline.com</p>	PRODUCT DRAWING		REFERENCE DWG(S):	SUBMITTAL NO: S00017240
	TITLE: PREASSEMBLED STRUT FITTING 4 HOLE SPLICE CLEVIS FOR B22 B172PA			DRAWN BY: ERN REV: A DATE: 08/19/2010
	<small>EQUIPMENT FURNISHED HAS BEEN FABRICATED IN ACCORDANCE WITH THIS DRAWING.</small>		MODEL SOURCE FILE: 00017240 REV: 00	SHEET: 1 OF 1

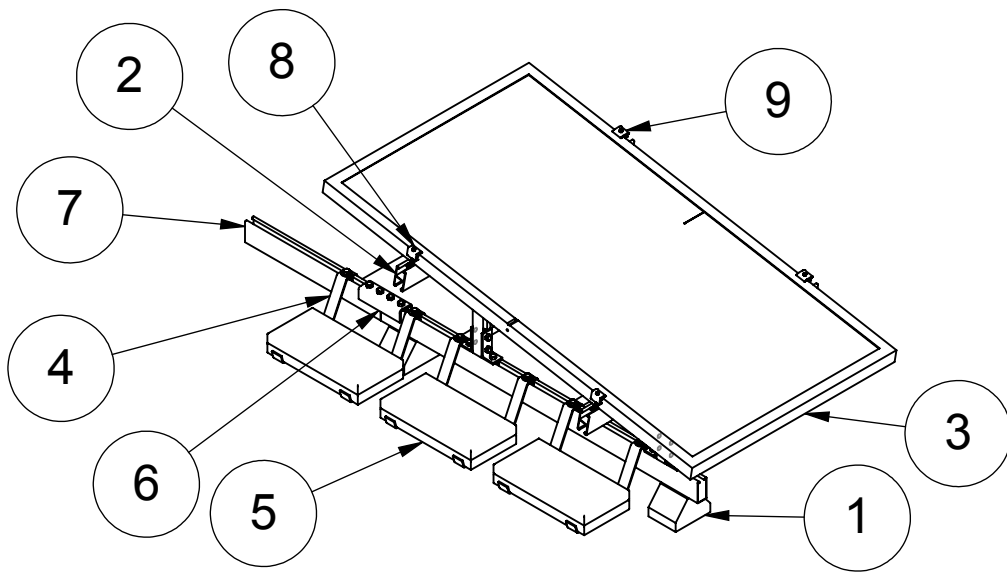
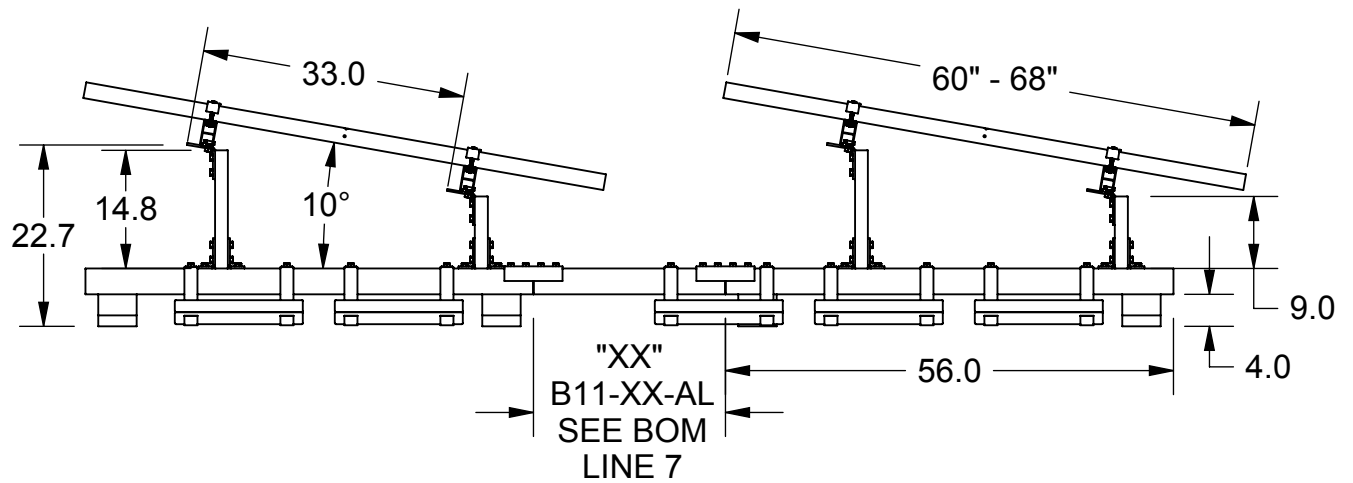

9	SHDENDXX PA AL W SS
8	SHDMIDXX PA AL W SS
7	B11-XX AL - LENGTH TO SET ROW SPACING
6	B172PA FOUR HOLE SPLICE, PREASSEMBLED
5	LANDSCAPE PAVER 16" X 8" X 1.5" 17LBS - CUSTOMER SUPPLIED
4	SRTBS-1PA BALLAST STRIP - PRE ASSEMBLED
3	SOLAR MODULE, CUSTOMER SUPPLIED
2	B22A-AL
1	SRTM10PXXXX, ROOFTOP SOLAR SUPPORT 10 DEGREE MONOLITHIC PORTRAIT
ITEM NO.	DESCRIPTION

BILL OF MATERIAL

THIS DRAWING AND/OR THE TECHNICAL INFORMATION CONTAINED HEREON IS THE PROPERTY OF COOPER B-LINE, INC. ("B-LINE"), AND IS ISSUED IN CONFIDENCE FOR B-LINE ENGINEERING PURPOSES ONLY AND MAY NOT BE REPRODUCED OR USED FOR ANY PURPOSE WHATSOEVER WITHOUT THE EXPRESS WRITTEN PERMISSION OF B-LINE TO THE USER. THIS DRAWING AND/OR TECHNICAL INFORMATION IS THE PROPERTY OF B-LINE AND IS LOANED FOR MUTUAL ASSISTANCE. TO BE RETURNED WHEN ITS INTENDED PURPOSE HAS BEEN SERVED.

 <p>509 W. Monroe Street Highland, IL 62249 Phone (618) 654-2184 FAX (618) 654-5499 www.cooperbline.com</p>	SUBMITTAL DRAWING		REFERENCE DWG(S): 00017106 00018216 00003117 00017240 00000018 00000018	SUBMITTAL NO: S00018181
	TITLE: ARISTA MONOLITHIC ROOFTOP SOLAR RACKING SYSTEM 10 DEGREE PORTRAIT 60"-68" SOLAR MODULES		MODEL SOURCE FILE: S00018181	DRAWN BY: ERN REV: A DATE: 01/27/2011
	<small>EQUIPMENT FURNISHED HAS BEEN FABRICATED IN ACCORDANCE WITH THIS DRAWING.</small>		REV:	SHEET: 1 OF 1

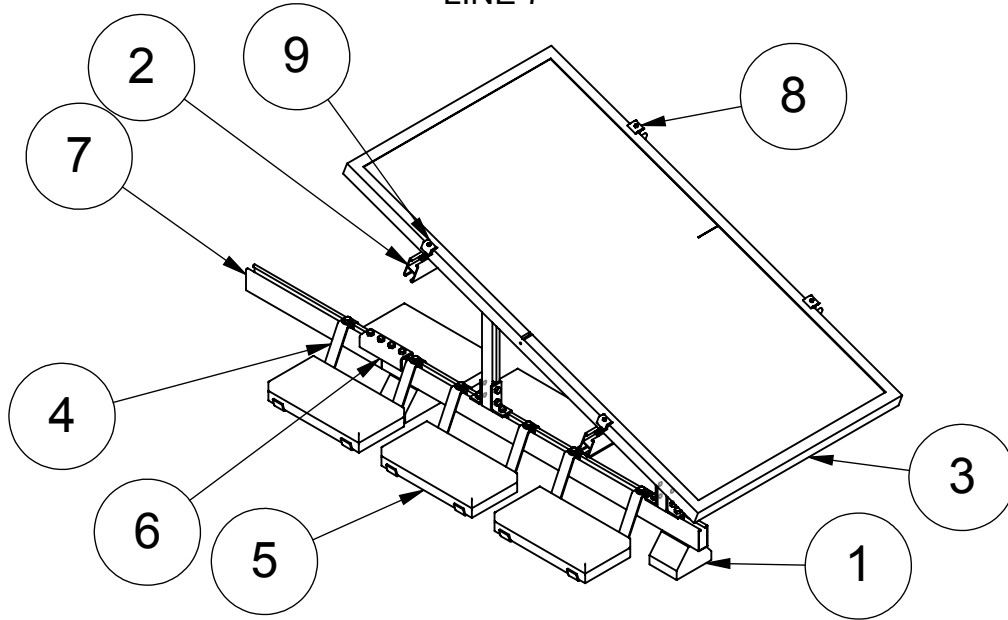
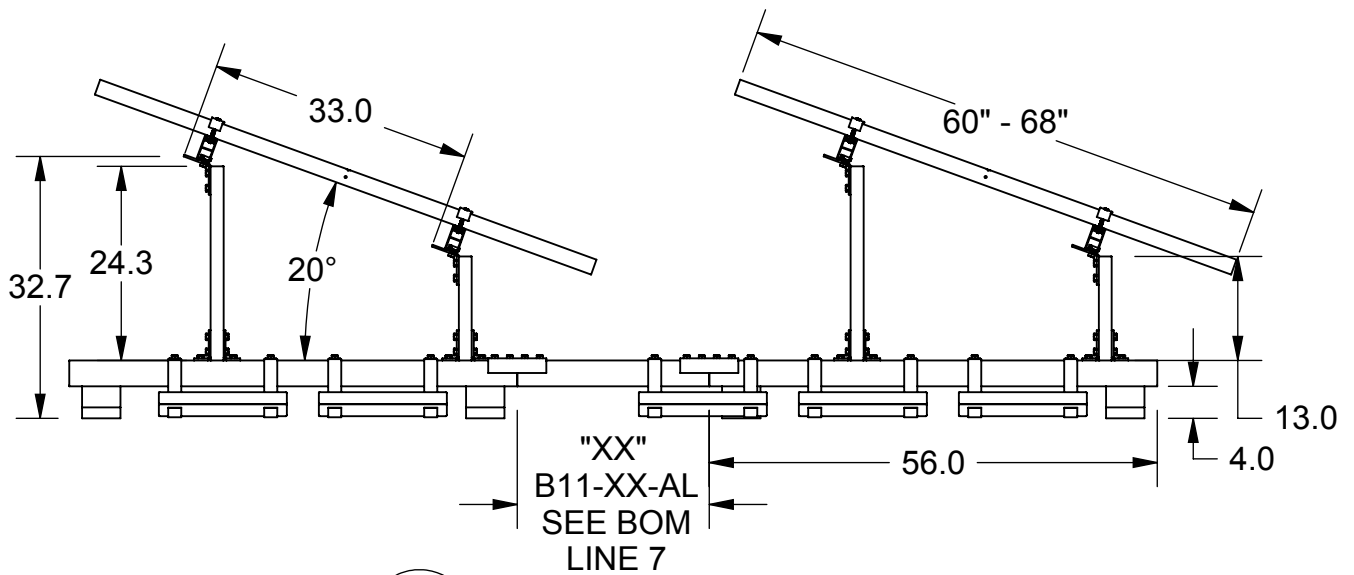

9	SHDENDXX PA AL W/SS
8	SHDMIDXX PA AL W SS
7	B11-XX AL - LENGTH TO SET ROW SPACING
6	B172PA FOUR HOLE SPLICE, PREASSEMBLED
5	LANDSCAPE PAVER 16" X 8" X 1.5" 17LBS - CUSTOMER SUPPLIED
4	SRTBS-1PA BALLAST STRIP - PRE ASSEMBLED
3	SOLAR MODULE, CUSTOMER SUPPLIED
2	B22A-AL
1	SRTM20PXXXX, ROOFTOP SOLAR SUPPORT 20 DEGREE MONOLITHIC PORTRAIT
ITEM NO.	DESCRIPTION

BILL OF MATERIAL

THIS DRAWING AND/OR THE TECHNICAL INFORMATION CONTAINED HEREON IS THE PROPERTY OF COOPER B-LINE, INC. ("B-LINE"), AND IS ISSUED IN CONFIDENCE FOR B-LINE ENGINEERING PURPOSES ONLY AND MAY NOT BE REPRODUCED OR USED FOR ANY PURPOSE WHATSOEVER WITHOUT THE EXPRESS WRITTEN PERMISSION OF B-LINE TO THE USER. THIS DRAWING AND/OR TECHNICAL INFORMATION IS THE PROPERTY OF B-LINE AND IS LOANED FOR MUTUAL ASSISTANCE. TO BE RETURNED WHEN ITS INTENDED PURPOSE HAS BEEN SERVED.

 <p>509 W. Monroe Street Highland, IL 62249 Phone (618) 654-2184 FAX (618) 654-5499 www.cooperbline.com</p>	SUBMITTAL DRAWING		REFERENCE DWG(S): 00018181 00017106 00018216 00003117 00017240 00000018	SUBMITTAL NO: S00018182
	TITLE: ARISTA MONOLITHIC ROOFTOP SOLAR RACKING SYSTEM 20 DEGREE PORTRAIT 60"-68" SOLAR MODULES		MODEL SOURCE FILE: 00018175	DRAWN BY: ERN REV: A DATE: 01/27/2011
	<small>EQUIPMENT FURNISHED HAS BEEN FABRICATED IN ACCORDANCE WITH THIS DRAWING.</small>		REV: 00	SHEET: 1 OF 1

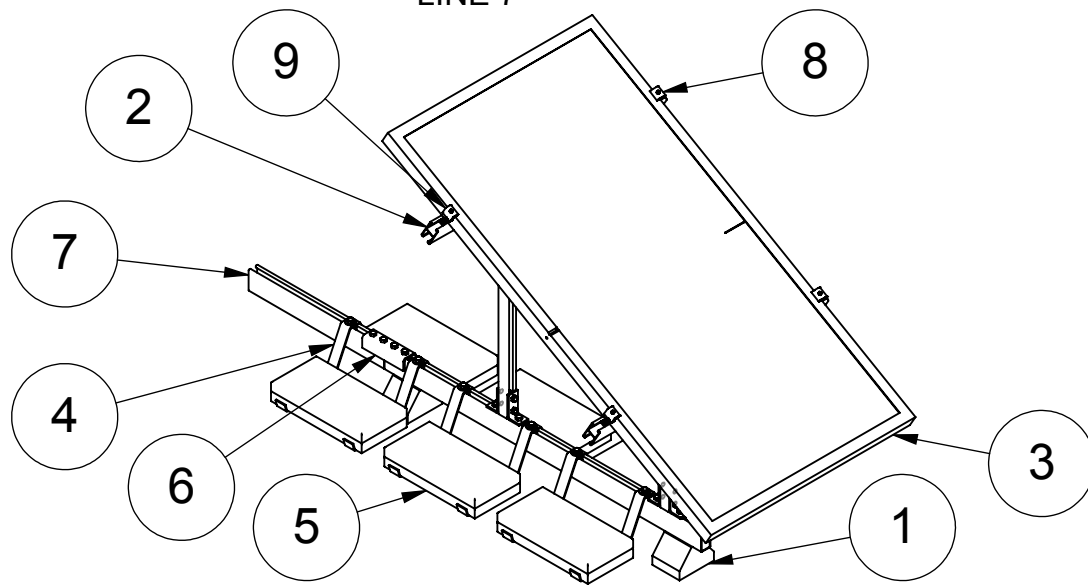
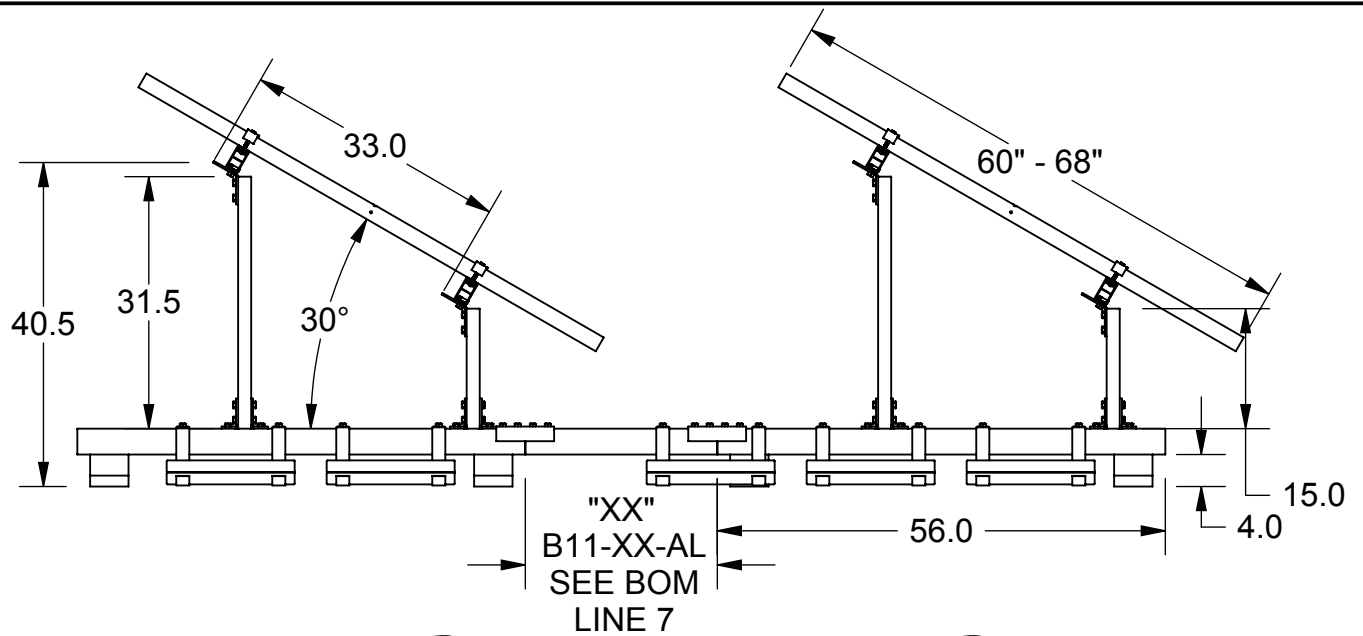

9	SHDENDXX PA AL W/SS
8	SHDMIDXX PA AL W SS
7	B11-XX AL - LENGTH TO SET ROW SPACING
6	B172PA FOUR HOLE SPLICE, PREASSEMBLED
5	LANDSCAPE PAVER 16" X 8" X 1.5" 17LBS - CUSTOMER SUPPLIED
4	SRTBS-1PA BALLAST STRIP - PRE ASSEMBLED
3	SOLAR MODULE, CUSTOMER SUPPLIED
2	B22A-AL
1	SRTM30DXXXX, ROOFTOP SOLAR SUPPORT 30 DEGREE MONOLITHIC PORTRAIT

ITEM NO.	DESCRIPTION
----------	-------------

BILL OF MATERIAL

THIS DRAWING AND/OR THE TECHNICAL INFORMATION CONTAINED HEREON IS THE PROPERTY OF COOPER B-LINE, INC. ("B-LINE"), AND IS ISSUED IN CONFIDENCE FOR B-LINE ENGINEERING PURPOSES ONLY AND MAY NOT BE REPRODUCED OR USED FOR ANY PURPOSE WHATSOEVER WITHOUT THE EXPRESS WRITTEN PERMISSION OF B-LINE TO THE USER. THIS DRAWING AND/OR TECHNICAL INFORMATION IS THE PROPERTY OF B-LINE AND IS LOANED FOR MUTUAL ASSISTANCE. TO BE RETURNED WHEN ITS INTENDED PURPOSE HAS BEEN SERVED.

<p>509 W. Monroe Street Highland, IL 62249 Phone (618) 654-2184 FAX (618) 654-5499 www.cooperbline.com</p>	SUBMITTAL DRAWING		REFERENCE DWG(S): 00017106 00018216 00003117 00017240 00000018	SUBMITTAL NO: S00018183
	TITLE: ARISTA MONOLITHIC ROOFTOP SOLAR RACKING SYSTEM 30 DEGREE PORTRAIT 60"-68" SOLAR MODULES		MODEL SOURCE FILE: 00018175	DRAWN BY: ERN REV: A DATE: 01/27/2011
	EQUIPMENT FURNISHED HAS BEEN FABRICATED IN ACCORDANCE WITH THIS DRAWING.		REV: 00	SHEET: 1 OF 1

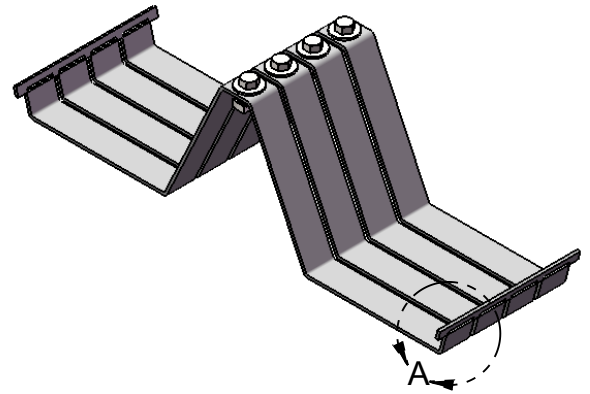
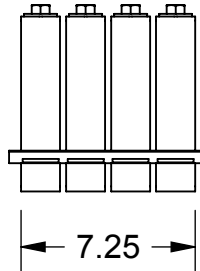
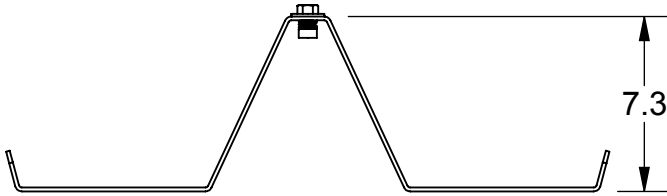
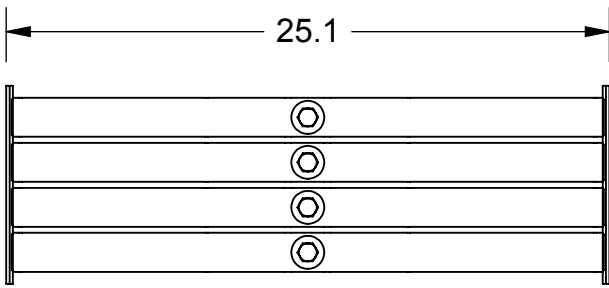

AS SHIPPED-BLOCKS OF FOUR (4)

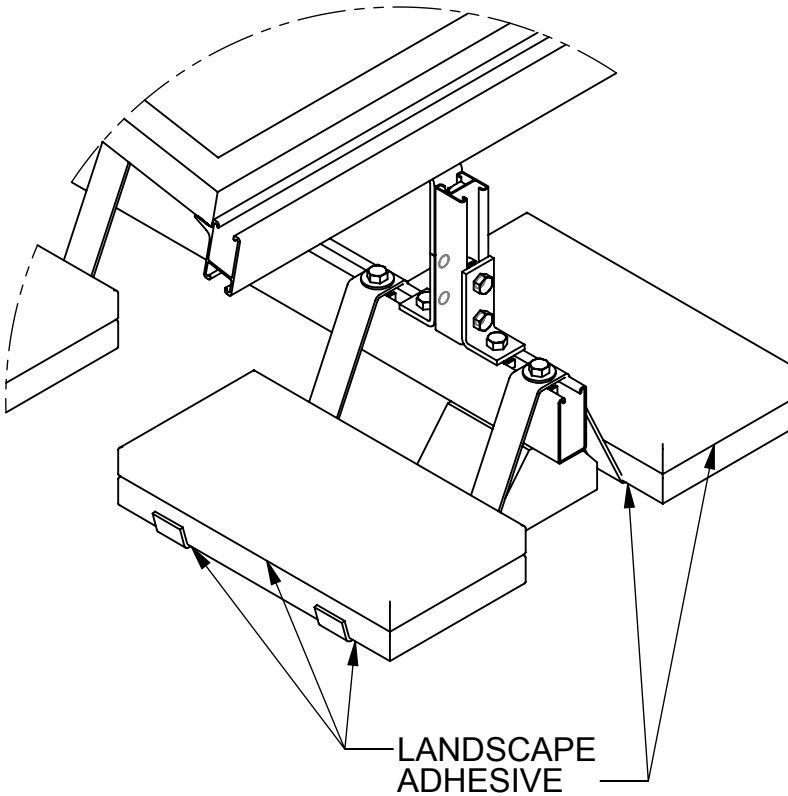

SHIPPING TAB
BEND TO REMOVE
BEFORE USE

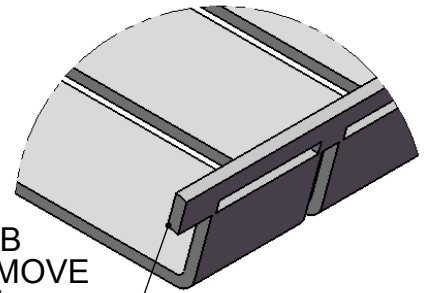

DETAIL A

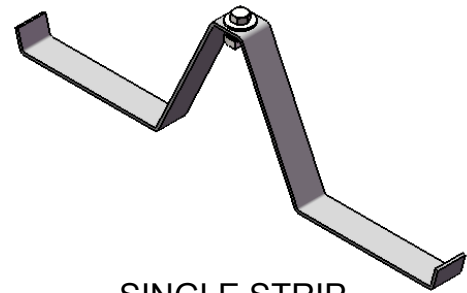

SINGLE STRIP

- USE STANDARD 8" x 16" x 1.5" 17 LB LANDSCAPE PAVERS
- EACH PAIR OF SINGLE STRIPS DESIGNED FOR FOUR PAVERS TOTALLING 68 LBS
- PAVERS TO BE ATTACHED TO EACH BALLAST STRIPS AND TO EACH OTHER WITH LANDSCAPE ADHESIVE
- MATERIAL: 0.16" ALUMINUM

THIS DRAWING AND/OR THE TECHNICAL INFORMATION CONTAINED HEREON IS THE PROPERTY OF COOPER B-LINE, INC. ("B-LINE"), AND IS ISSUED IN CONFIDENCE FOR B-LINE ENGINEERING PURPOSES ONLY AND MAY NOT BE REPRODUCED OR USED FOR ANY PURPOSE WHATSOEVER WITHOUT THE EXPRESS WRITTEN PERMISSION OF B-LINE TO THE USER. THIS DRAWING AND/OR TECHNICAL INFORMATION IS THE PROPERTY OF B-LINE AND IS LOANED FOR MUTUAL ASSISTANCE. TO BE RETURNED WHEN ITS INTENDED PURPOSE HAS BEEN SERVED.



509 W. Monroe Street
Highland, IL 62249
Phone (618) 654-2184
FAX (618) 654-5499

www.cooperbline.com

SUBMITTAL DRAWING

TITLE:

SRTBS-1 PA
SOLAR ROOFTOP BALLAST
STRIP PRE-ASSEMBLED

REFERENCE DWG(S):

SUBMITTAL NO:

S00018216

DRAWN BY: REV.

ERN

DATE:
01/19/2011

MODEL SOURCE FILE:

00018216

REV:

00

SHEET:

1 OF 1

EQUIPMENT FURNISHED HAS BEEN FABRICATED IN ACCORDANCE WITH THIS DRAWING.

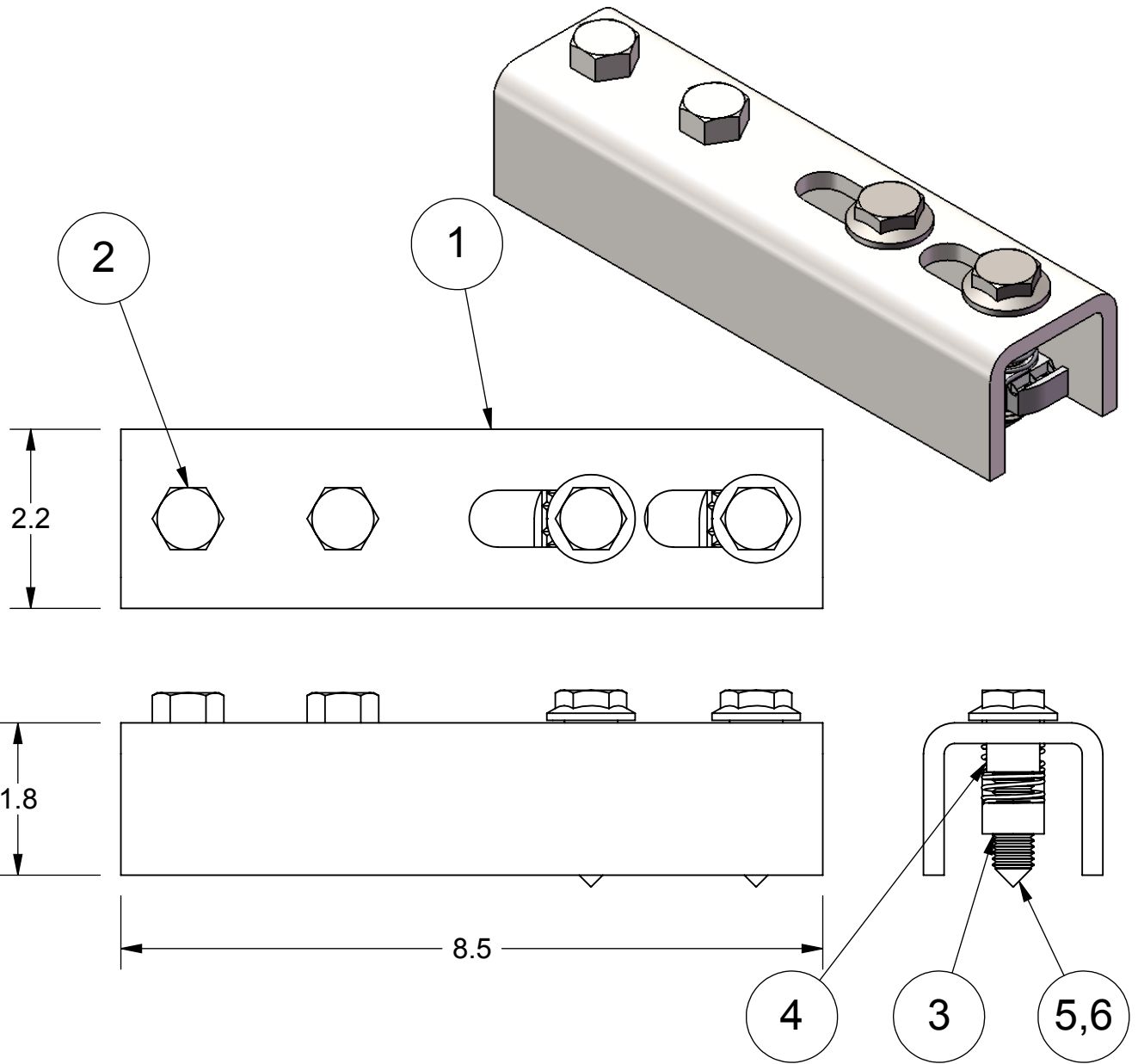

6	HEX WASHER HEAD SCREW-CONE POINT 1/2-13 X 1 3/8"	2	-
5	HEX WASHER HEAD SCREW-CONE POINT 1/2-13 X 2 1/8"	-	2
4	1/2" I.D. X 5/8" LENGTH SPACER	2	2
3	N525PA CHANNEL NUT	4	4
2	HEX HEAD SCREW 1/2-13 X 7/8"	2	2
1	ARISTA EXPANSION SPLICE FITTING	1	1
ITEM NO.	DESCRIPTION	B172ESPL PA/QTY.	B172ESP P PA/QTY.

BILL OF MATERIAL

THIS DRAWING AND/OR THE TECHNICAL INFORMATION CONTAINED HEREON IS THE PROPERTY OF COOPER B-LINE, INC. ("B-LINE"), AND IS ISSUED IN CONFIDENCE FOR B-LINE ENGINEERING PURPOSES ONLY AND MAY NOT BE REPRODUCED OR USED FOR ANY PURPOSE WHATSOEVER WITHOUT THE EXPRESS WRITTEN PERMISSION OF B-LINE TO THE USER. THIS DRAWING AND/OR TECHNICAL INFORMATION IS THE PROPERTY OF B-LINE AND IS LOANED FOR MUTUAL ASSISTANCE. TO BE RETURNED WHEN ITS INTENDED PURPOSE HAS BEEN SERVED.

 509 W. Monroe Street Highland, IL 62249 Phone (618) 654-2184 FAX (618) 654-5499 www.cooperbline.com	SUBMITTAL DRAWING		REFERENCE DWG(S):	SUBMITTAL NO: SSK2987	
	TITLE:	B172ESPLPAZN B172ESPPPAZN ARISTA MONOLITHIC EXPANSION SPLICE		DRAWN BY: ERN	REV. A
				DATE: 02/02/2011	SHEET: 1 OF 1
		<small>EQUIPMENT FURNISHED HAS BEEN FABRICATED IN ACCORDANCE WITH THIS DRAWING.</small>		MODEL SOURCE FILE: SK2987	REV: 00

- SECURES SOLAR ROOFTOP ASSEMBLY TO ROOF*
- USE IN PLACE OF BALLAST TRAY TO REDUCE DEAD LOAD ON ROOFTOP
- INCLUDES HARDWARE NECESSARY TO ATTACH TO SOLAR ROOFTOP ASSEMBLY

CATALOG NUMBER:
SRTMK-1

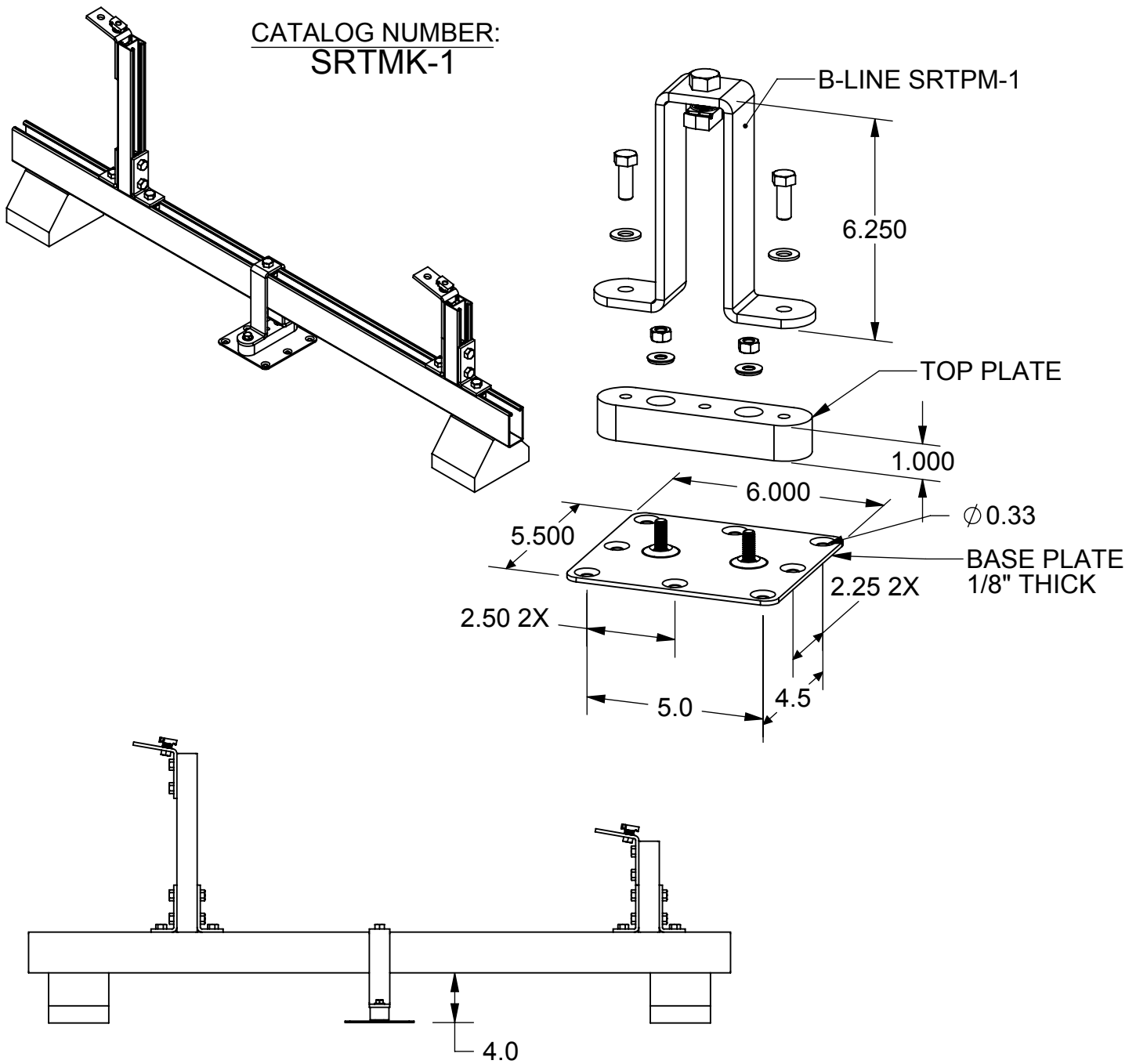

INSTALLED VIEW

- * FOR ROOFS WITH INSULATION BETWEEN DECKING AND MEMBRANE, CORE OUT INSULATION AND PLACE ALUMINUM FERRULES BETWEEN DECKING AND BASE PLATE
- ** COLORED ALUMINUM FLASHING COMES IN MATTE BLACK OR DARK BRONZE

THIS DRAWING AND/OR THE TECHNICAL INFORMATION CONTAINED HEREON IS THE PROPERTY OF COOPER B-LINE, INC. ("B-LINE"), AND IS ISSUED IN CONFIDENCE FOR B-LINE ENGINEERING PURPOSES ONLY AND MAY NOT BE REPRODUCED OR USED FOR ANY PURPOSE WHATSOEVER WITHOUT THE EXPRESS WRITTEN PERMISSION OF B-LINE TO THE USER. THIS DRAWING AND/OR TECHNICAL INFORMATION IS THE PROPERTY OF B-LINE AND IS LOANED FOR MUTUAL ASSISTANCE. TO BE RETURNED WHEN ITS INTENDED PURPOSE HAS BEEN SERVED.

 509 W. Monroe Street Highland, IL 62249 Phone (618) 654-2184 FAX (618) 654-5499 www.cooperbline.com	SUBMITTAL DRAWING		REFERENCE DWG(S):	SUBMITTAL NO: S00017810
	TITLE: SOLAR ROOFTOP MOUNTING KIT			DRAWN BY: TCS
				REV:
				DATE: 06/28/10
		EQUIPMENT FURNISHED HAS BEEN FABRICATED IN ACCORDANCE WITH THIS DRAWING.	MODEL SOURCE FILE: 00017810	REV: 01
				SHEET: 1 OF 1