

Cable Cleats

Protect Your Investments

CTCC-10

**COOPER B-Line**



Introduction

Protect your People



Protect your Cables



Protect your Systems



Cooper B-Line Cable Cleats are designed to support and retain your cables within your cable tray system in everyday conditions. More importantly, they help prevent damage in short circuit conditions. Unfortunately, short circuits do happen, and when they do, they are destructive and dangerous. Cable Cleats are one of the first lines of defense to help protect your personnel, your cables and your cable tray systems.

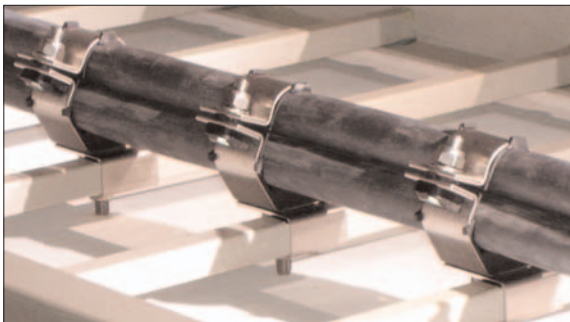

Properly restrained cables shown before a short circuit.



Properly restrained cables shown after a short circuit.

In the event of a short circuit, correctly installed cable cleats can restrain the cables within the tray, helping avoid cable breaks that can cause damage to the tray systems and injury to your personnel. Not only is this a prudent product to install, the National Electrical Code (NEC) requires adequate cable restraint in article 392.8 (D).

“Parallel connected single conductor cables shall be securely bound in circuit groups to prevent excessive movement due to fault current magnetic forces.”
NEC, Article 392.8 (D).

The cleats in this catalog are covered under IEC Standard 61914.

Cable cleats also help avoid downtime caused by short circuits. They help prevent the need for expensive repairs and downtime caused by short circuit damages.

Step by Step Installation

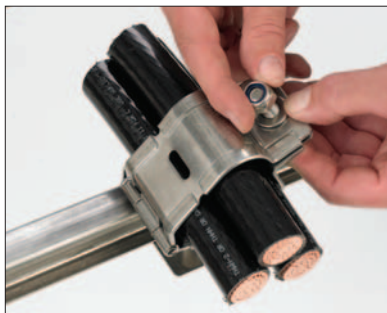
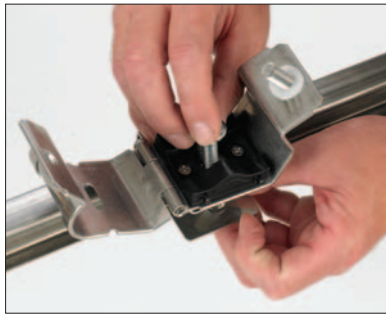
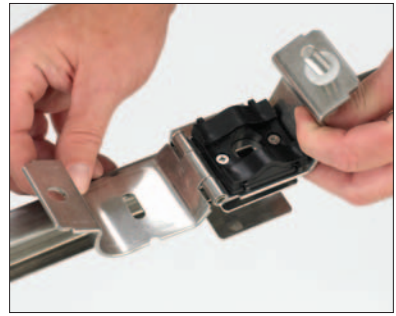
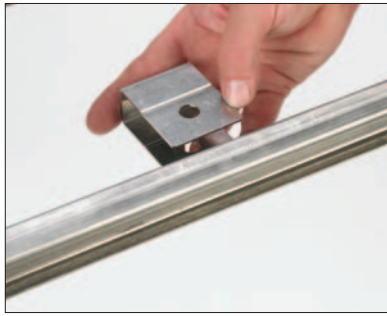

Cable Cleat Selection and Specification

Step 1: Know Your Cables

- What type of cable is being used?
 - Single or Multi-conductor
- What is the outside diameter of the cable(s)?
- What is the cable arrangement (single conductor cables only)?
 - Flat or Trefoil
- If a ground wire will be installed within the cleat, you will need the ground wire outside diameter.

Step 2: Know Your System

- What is the available short circuit current (RMS or i_p (peak))?
- What type of Cooper B-Line cable tray is installed?

Step 3: Select Your Cable Cleats

- See Pages 6 & 7

Step 4: Select Your Mounting Bracket

Mounting brackets are used to attach cable cleats to the rungs of the ladder type cable trays. Your tray type will determine the mounting bracket used.

Cooper B-Line Tray Types	Mounting Bracket
Aluminum welded rung trays with standard rungs. Steel Series 2, 3, 4 or 5, trays with standard rungs Fiberglass trays with standard rungs	9SS6-CCB-C
REDI-Rail™ Cable Tray	9SS6-CCB-D
Steel trays with strut rungs Aluminum trays with "Marine Rungs"	9SS6-CCB-B
Steel Series 1 trays with standard rungs	9SS6-CCB-A

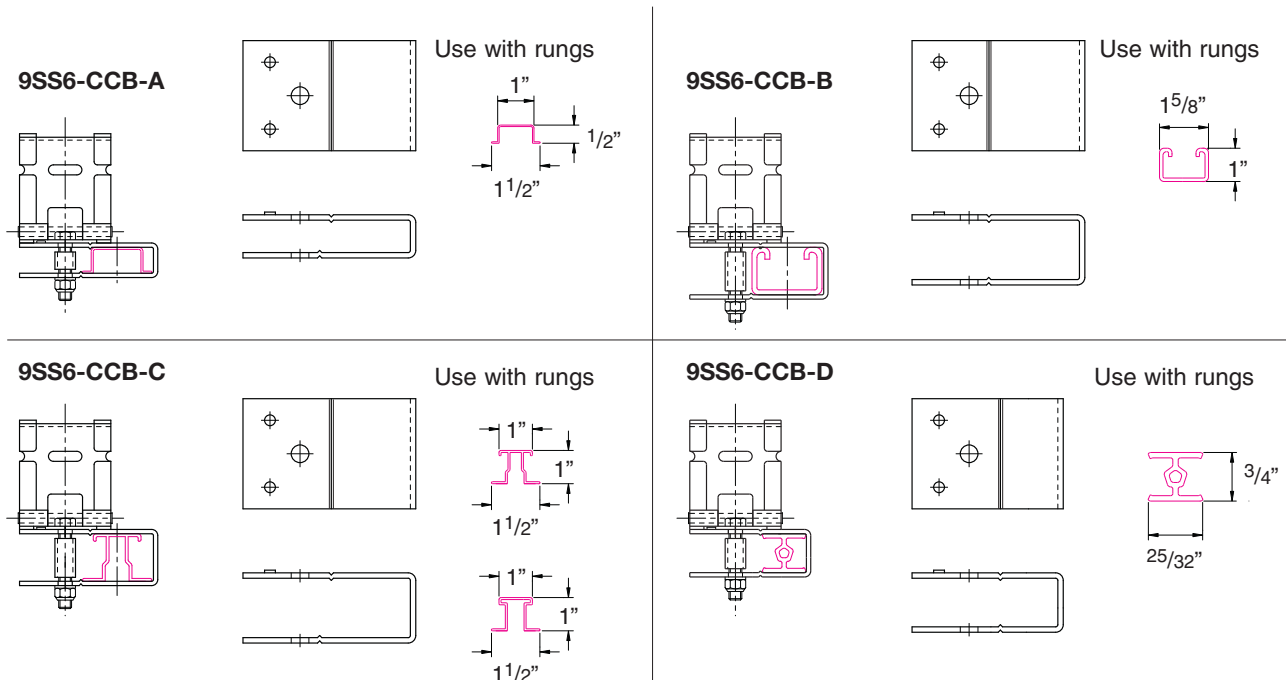

Step 5: Determine Cleat Spacing for Installation

Your cable diameter is equal to the spacing between conductor centers shown below. Find your cable diameter at the top of the table and look down at the column below it. Find the value equal to or greater than the available short circuit for your system.

Single Conductor Short Circuit Withstand Table													
Max. Cable Cleat Spacing (A)		Spacing Between Conductor Centers (mm)											
		23	25	27	29	31	33	35	37	39	41	43	45
mm	In.	i_p peak (kA)											
225	9	179	187	194	203	209	216	220	229	234	240	246	250
300	12	155	163	168	174	181	187	192	198	203	209	214	215
450	18	128	133	137	144	148	152	157	161	165	170	174	178
600	24	110	115	119	124	128	132	135	139	143	148	150	153
675	27	104	108	113	117	121	124	128	132	135	139	143	147
900	36	89	93	97	102	104	108	110	115	117	121	124	127

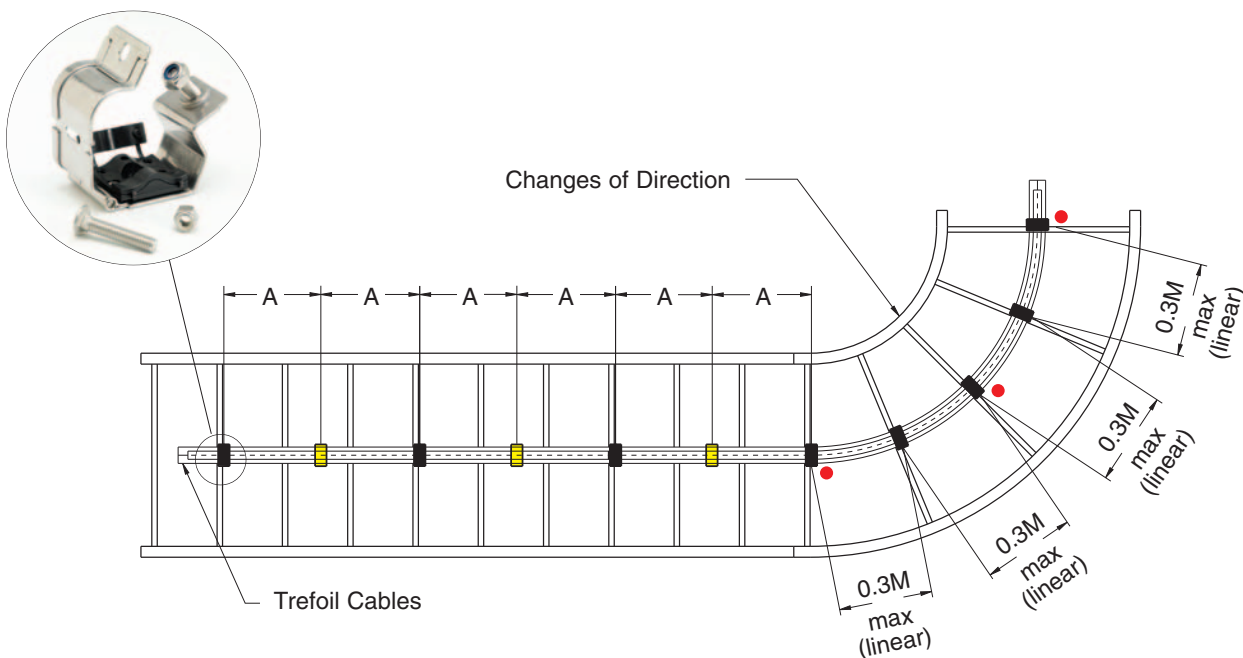

IMPORTANT: Recommended Installation Procedures

It is important that the cleats are installed properly to secure your cables:

- It is not necessary for every cleat to be attached to the tray. Every other cleat (■) must be attached to the tray system to mount cable in tray. Unattached cleats (□) provide additional restraint to keep cables bundled.
- The bend radius should be 8 to 12 times the cable diameter.
- Cleats should always be installed at the beginning, middle and end of a bend (●), and at no time should the distance between cleats on a bend be more than 0.3M center to center.

Cooper B-Line Sales Engineers are available to assist you in selecting your cable cleats.

Phone: (800) 851-7415 ext. 366

Trefoil Cable Cleats

Trefoil Cable Cleat with LSF Pad

1. Cable Cleats are recommended for installations where the highest levels of short circuit withstand are required.
2. Cable Cleats have been short circuit current tested in accordance with BS EN 50368:2003 standard.
3. Cable Cleats are available for single and trefoil cable applications.
4. Cable Cleat LSF-pad incorporate an integral low smoke, low fume, zero halogen pad.
5. Hardware to attach cleat to rung attachment bracket is included with cleat. Bracket must be ordered separately.

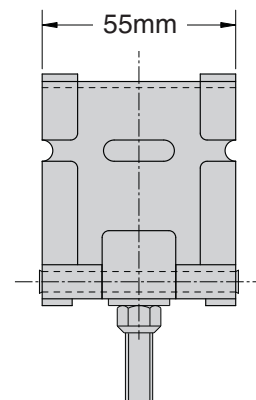
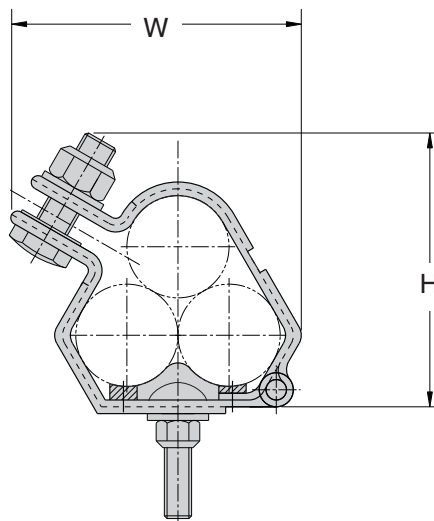

BS EN 50368:2003 (Cable Cleats for Electric Installations) Classification	
Cleat Type	Composite
Resistance to Electromechanical Force	130 kA peak / 50 kA RMS 600 mm spacing
Lateral Load Test	3.439 kg average
Axial Load Test	Pass
Operating Temperature Range	-40°C to +60°C
Impact Resistance	Very Heavy
Needle Flame Test	30 seconds

Technical Specifications	
Frame	50mm x 2mm Marine grade, Non-magnetic 316L
Closure Hardware	Captive 316 Stainless Steel M8 or M10 (M12 available) bolt and nylon-lock nut (Optional Hex Flange Lock Nut available)
Integral Pad	Low Smoke, Low Fume, Zero Halogen
Tools Required	Impact Wrench
Mounting Bolt	Provided with Cable Cleat

Part No.	Cable Range (mm)		Dimensions (mm)	
	Min. Dia.	Max. Dia.	H	W
9SS6-CCT1323	13	22	74	66
9SS6-CCT2125	21	25	77	70
9SS6-CCT2329	23	29	81	78
9SS6-CCT2531	25	31	84	81
9SS6-CCT2733	27	33	86	83
9SS6-CCT2935	29	35	90	89
9SS6-CCT3238	32	38	94	95
9SS6-CCT3541	35	41.5	98	100
9SS6-CCT3844	38	44.5	101	104
9SS6-CCT4248	42	48	105	111
9SS6-CCT4551	45	51	109	117
9SS6-CCT4753	47	53	111	120
9SS6-CCT4955	49	55	114	124
9SS6-CCT5157	51	57	116	127
9SS6-CCT5359	53	59	119	133
9SS6-CCT5561	55	61	127	137
9SS6-CCT5763	57	63	126	140
9SS6-CCT5965	59	65	128	144

Part No.	Cable Range (mm)		Dimensions (mm)	
	Min. Dia.	Max. Dia.	H	W
9SS6-CCT6167	61	67	132	147
9SS6-CCT6369	63	69	136	150
9SS6-CCT6571	65	71	140	153
9SS6-CCT6773	67	73	143	156
9SS6-CCT6975	69	75	147	160
9SS6-CCT7177	71	77	151	163
9SS6-CCT7379	73	79	154	166
9SS6-CCT7581	75	81	158	169
9SS6-CCT7783	77	83	161	173
9SS6-CCT7985	79	85	164	176
9SS6-CCT8187	81	87	169	179
9SS6-CCT8389	83	89	173	182
9SS6-CCT8896	88	96	181	192
9SS6-CCT96103	96	103	190	201
9SS6-CCT103111	103	111	199	204
9SS6-CCT111119	111	119	208	213
9SS6-CCT119128	119	128	217	221

Single Cable Cleat with LSF Pad

1. Cable Cleats are recommended for installations where the highest levels of short circuit withstand are required.
2. Cable Cleats have been short circuit current tested in accordance with BS EN 50368:2003 standard.
3. Cable Cleats are available for single and trefoil cable applications.
4. Cable Cleat LSF-pad incorporate an integral low smoke, low fume, zero halogen pad.
5. Hardware to attach cleat to rung attachment bracket is included with cleat. Bracket must be ordered separately.

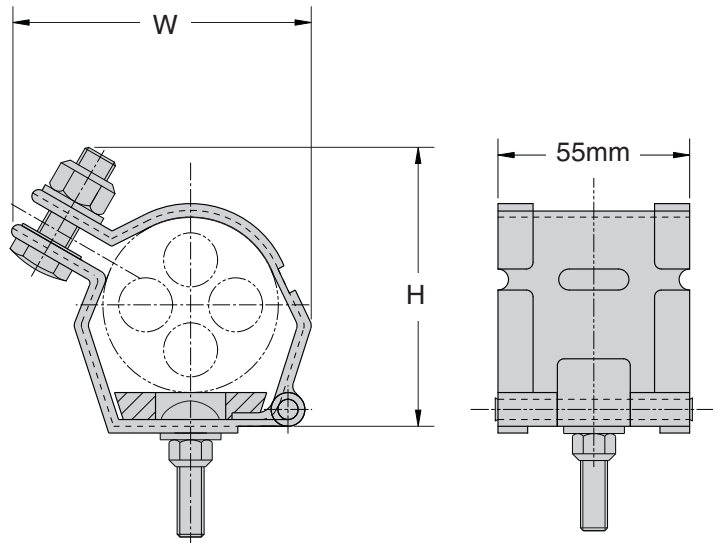
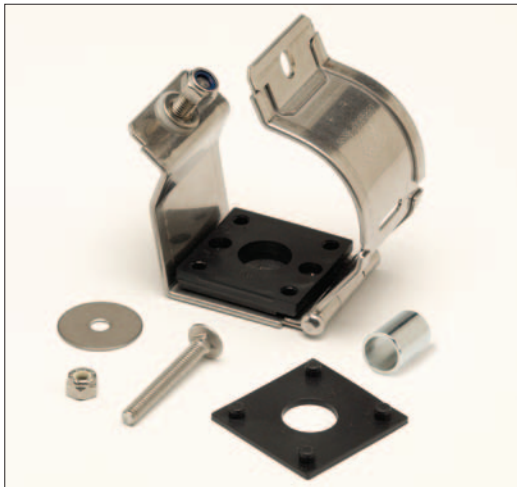

BS EN 50368:2003 (Cable Cleats for Electric Installations) Classification	
Cleat Type	Composite
Resistance to Electromechanical Force	130 kA peak / 50 kA RMS 600 mm spacing
Lateral Load Test	3.439 kg average
Axial Load Test	Pass
Operating Temperature Range	-40°C to +60°C
Impact Resistance	Very Heavy
Needle Flame Test	30 seconds

Technical Specifications	
Frame	50mm x 2mm Marine grade, Non-magnetic 316L
Closure Hardware	Captive 316 Stainless Steel M8 or M10 (M12 available) bolt and nylon-lock nut (Optional Hex Flange Lock Nut available)
Integral Pad	Low Smoke, Low Fume, Zero Halogen
Tools Required	Impact Wrench
Mounting Bolt	Provided with Cable Cleat

Part No.	Cable Range (mm)		Dimensions (mm)	
	Min. Dia.	Max. Dia.	H	W
9SS6-CCS2832	28	32	61	55
9SS6-CCS3034	30	34	63	57
9SS6-CCS3236	32	36	65	59
9SS6-CCS3438	34	38	67	61
9SS6-CCS3640	36	40	69	63
9SS6-CCS3842	38	42	71	65
9SS6-CCS4044	40	44	73	67
9SS6-CCS4246	42	46	75	69
9SS6-CCS4448	44	48	77	71
9SS6-CCS4650	46	50	79	73
9SS6-CCS4852	48	52	81	75
9SS6-CCS5054	50	54	83	77
9SS6-CCS5256	52	56	85	79
9SS6-CCS5458	54	58	87	81
9SS6-CCS5660	56	60	89	83
9SS6-CCS5862	58	62	91	85
9SS6-CCS6064	60	64	93	87

Part No.	Cable Range (mm)		Dimensions (mm)	
	Min. Dia.	Max. Dia.	H	W
9SS6-CCS6266	62	66	88	89
9SS6-CCS6468	64	68	90	91
9SS6-CCS6670	66	70	91	93
9SS6-CCS6872	68	72	93	95
9SS6-CCS7074	70	74	95	97
9SS6-CCS7276	72	76	97	99
9SS6-CCS7478	74	78	99	101
9SS6-CCS7680	76	80	101	103
9SS6-CCS7682	76	82	103	105
9SS6-CCS8084	80	84	105	107
9SS6-CCS8286	82	86	107	109
9SS6-CCS8488	84	88	109	111
9SS6-CCS8690	86	90	110	113
9SS6-CCS9094	90	94	116	120
9SS6-CCS94118	94	118	135	137
9SS6-CCS118130	118	130	141	143
9SS6-CCS127150	127	150	162	165

Cooper B-Line Product Lines

Strut Systems (Bolted Framing)
Cable Tray Systems
Electrical Enclosures
Electronic Enclosures
Metering
Pipe Hangers & Support Systems
Spring Steel Fasteners
Cable Runway & Relay Racks (CommData)
Meter Mounting & Distribution Equipment
Safety Grating
Anchors

CTCC-10

Cooper B-Line

509 West Monroe Street
Highland, IL 62249
Phone: 800-851-7415
Fax: 618-654-1917

www.cooperbline.com

• Contact Information •



SYSTEMS THAT MAKE SENSE

Cooper Industries, Ltd.
600 Travis, Ste. 5800
Houston, TX 77002-1001
Phone: 713-209-8400
www.cooperindustries.com