

Grip Strut® Safe Loading Tables

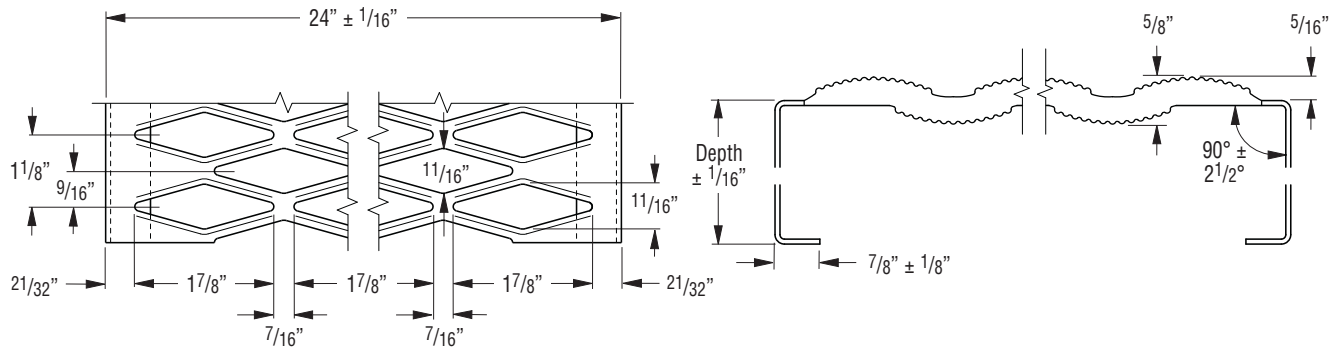

10-Diamond Plank — 24" Width



Product Selection/Design Tables

Allowable Loads and Deflections: U=Uniform Load (lb./ft.²) C= Concentrated Load (lb.) D=Deflection (in.)
Spans to the left of heavy red line produce a deflection of 1/4" or less under a uniform load of 100 lb./ft.²

Material Gauge	Channel Depth in. (mm)	Weight lb./lin. ft. (kg/m)	Catalog Number	Span																			
				2'-0"	2'-6"	3'-0"	3'-6"	4'-0"	4'-6"	5'-0"	5'-6"	6'-0"	6'-6"	7'-0"	7'-6"	8'-0"	9'-0"	10'-0"	11'-0"	12'-0"			
Steel 14 ga.	2" (50.8)	7.4 (11.0)	102014	U	300	300	228	168	128	102	82	68	57	49	42								
				D	.46	.48	.42	.38	.38	.41	.44	.49	.55	.62	.70								
				C	400	400	343	294	257	229	206	187	172	158	147								
				D	.34	.35	.32	.30	.29	.29	.30	.31	.33	.35	.37								
	3" (76.2)	7.9 (11.8)	103014	U	300	300	300	264	202	160	130	107	90	77	66	58	51	40					
				D	.42	.43	.46	.44	.39	.36	.35	.36	.39	.44	.45	.49	.54	.65					
				C	400	400	400	400	400	360	324	295	270	249	232	216	203	180					
				D	.33	.33	.34	.35	.37	.35	.33	.33	.32	.32	.33	.34	.35	.38					
Steel 12 ga.	2" (50.8)	19.4 (15.5)	102012	U	475	416	289	212	162	128	104	86	72	62	53	46							
				D	.40	.39	.33	.31	.31	.34	.38	.44	.48	.56	.63	.71							
				C	650	520	434	372	325	289	260	237	217	200	186	174							
				D	.26	.22	.19	.20	.20	.21	.22	.23	.25	.28	.31	.34							
	3" (76.2)	11.1 (16.5)	103012	U	475	475	475	392	300	237	192	159	133	114	98	85	75	59	48				
				D	.38	.39	.42	.38	.36	.34	.35	.37	.39	.43	.47	.52	.58	.70	.85				
				C	900	900	800	686	600	534	480	437	400	369	343	320	300	267	240				
				D	.34	.35	.33	.29	.27	.26	.26	.26	.26	.27	.29	.30	.32	.36	.41				

Engineering Data For Both Channels

Material Gauge	Channel Depth-in.	Sx in. ³	Ix in. ⁴	EI lb. x in. ²
Steel 14 ga.	2"	.303	.232	6.73 x 10 ⁶
Steel 14 ga.	3"	.484	.713	20.68 x 10 ⁶
Steel 12 ga.	2"	.387	.346	10.03 x 10 ⁶
Steel 12 ga.	3"	.715	.959	27.81 x 10 ⁶

Strut Loading

Material Gauge	Type Loading**	Load	Deflection in.
Steel 14 ga.	U	300	.49
	Cs	300	.40
Steel 12 ga.	U	475	.45
	Cs	475	.36

** U = Allowable Uniform Load (lb./ft.²)
Cs = Allowable Concentrated Load per ft. of length at mid-width (lb./ft.)



Grip Strut® Safe Loading Tables

10-Diamond Walkway — 24" Width

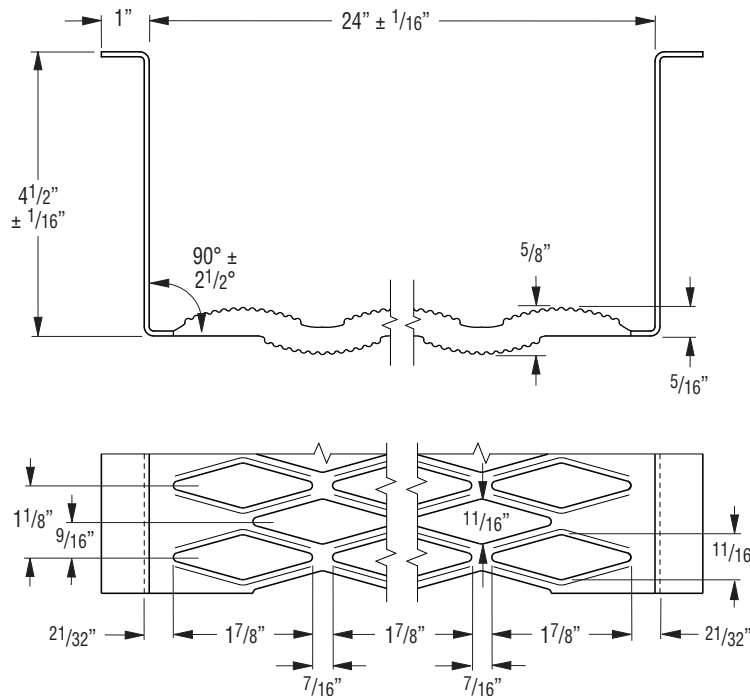

Product Selection/Design Tables

Allowable Loads and Deflections: U=Uniform Load (lb./ft.²) C= Concentrated Load (lb.) D=Deflection (in.)
Spans to the left of heavy red line produce a deflection of 1/4" or less under a uniform load of 100 lb./ft.²

Material Gauge	Weight lb./in. ft. (kg/m)	Catalog Number	Span																	
			2'-0"	2'-6"	3'-0"	3'-6"	4'-0"	4'-6"	5'-0"	5'-6"	6'-0"	6'-6"	7'-0"	7'-6"	8'-0"	9'-0"	10'-0"	11'-0"	12'-0"	
Steel 14 ga	8.9 (13.2)	104514-U	U	300	300	300	300	300	263	213	176	148	126	109	95	83	66	53	43	
			D	.41	.41	.42	.45	.48	.47	.42	.40	.40	.41	.43	.45	.47	.55	.64	.75	
			C	400	400	400	400	400	400	400	400	400	400	380	355	333	296	266	242	
			D	.32	.33	.33	.33	.34	.35	.36	.38	.39	.41	.42	.41	.41	.42	.44	.47	
Steel 12 ga	12.5 (18.6)	104512-U	U	475	475	475	475	475	420	340	281	236	201	173	151	133	105	85	70	59
			D	.37	.37	.38	.40	.43	.43	.39	.37	.37	.37	.39	.41	.44	.51	.59	.69	.80
			C	900	900	900	900	900	900	850	773	709	654	607	567	531	472	425	387	354
			D	.34	.34	.35	.35	.36	.37	.37	.35	.34	.33	.33	.33	.33	.33	.35	.37	.40

Engineering Data For Both Channels

Material Gauge	Channel Depth-in.	Sx in. ³	Ix in. ⁴	EI lb. x in. ²
Steel 14 ga.	4 1/2"	.806	1.43	41.47 x 10 ⁶
Steel 12 ga.	4 1/2"	1.290	2.42	10.03 x 10 ⁶

Strut Loading

Material Gauge	Type Loading**	Load	Deflection in.
Steel 14 ga.	U	300	.49
	Cs	300	.40
Steel 12 ga.	U	475	.45
	Cs	475	.36

** U = Allowable Uniform Load (lb./ft.²)
Cs = Allowable Concentrated Load per ft. of length at mid-width (lb./ft.)