



GRATE-LOCK™ Grating

Solid Deck Planking & LAMBDA-LOK™

Strength, Safety, Selection & Savings

GSGLG-10

**COOPER B-Line**

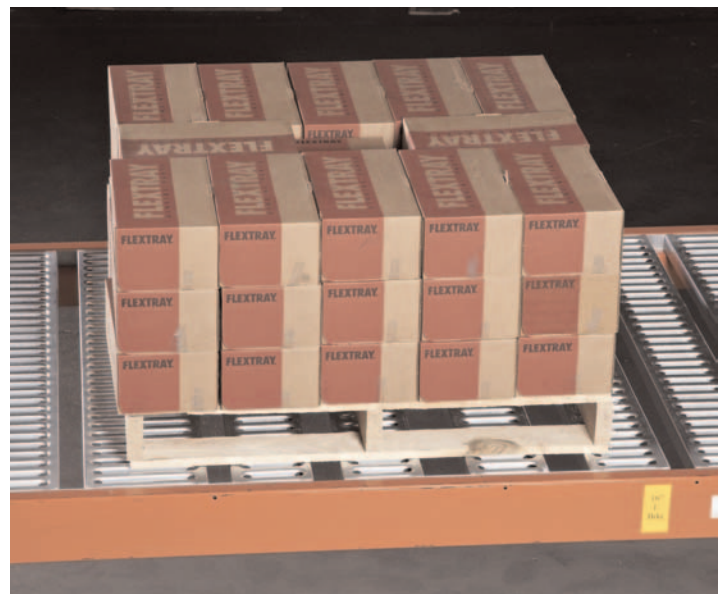

Table of Contents & Advantages

Advantages	2
How to Specify	2
Proof of Performance	3
Applications	4
Specifications	5
System Components	6-7
GRATE-LOCK Loading Tables (6", 9", & 12" Widths)	
1 1/2" Channel Height	8-9
2 1/2" Channel Height	10-11
3" Channel Height	12-13
4" Channel Height	14-15
Solid Deck Planking	16-17
LAMBDA-LOK™	18-19

GRATE-LOCK™

With Sole-Gripping Dimples



Without Dimples



- Cost-saving design
- Wide range of sizes, accessories
- Fast field assembly
- Traction grip and plain surfaces
- Choice of two standard gauges: 14 and 18
Special 16 gauge is available

Solid Deck Planking

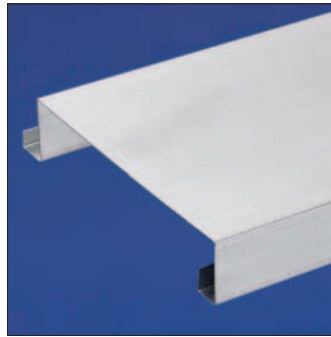

- Solid Deck is a durable, solid surface
- Low-cost installation & low maintenance
- Easy to replace
- Pre-galvanized with a variety of uses

LAMBDA-LOK™

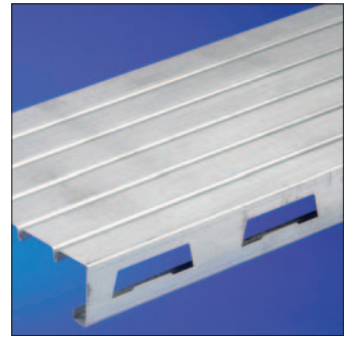

- LAMBDA-LOK is a durable, pre-galvanized surface
- Low-cost installation & low maintenance
- Easy to replace
- Heavy loads over long spans
- Add extra Lambda-Loks for concentrated loads

GRATE-LOCK™ grating is an easy-to-install system of interlocking grating planks, treads, and accessories that provides safe, sturdy footing for mezzanine floors, platforms, walkways and other applications where non-slip performance is required. Hundreds of sole-gripping dimples insure a safe surface in all kinds of weather and environments. The grating is available textured for safer working surfaces and non-textured for wheeled traffic or rack decking.



Design Improves Loading Performance

The unique design of GRATE-LOCK grating provides more design options. Increased load performance (see charts pages 8-15) has been achieved through interlocking planks, stronger rung design and an expanded selection of leg heights and material gauges. GRATE-LOCK lets you specify lighter gauge steel for substantial material savings.

More Sizes and Gauges

GRATE-LOCK grating provides one of the broadest line of grating products of any manufacturer.

- Three (3) plank width options
- Four (4) plank height options
- Three (3) gauge options
- Lengths up to 24 feet

Interlocking sections provide the strength you need for extra-wide designs.

Full Line of Accessories

Our line includes kickplates, hold-down clamps, attachment hardware and stair treads for complete job design.

Fast Bolt-Together Assembly

Helps save time in the field with Grate-Lock bolt-together slotted assemblies. Kickplates and plank sections are prepunched. For additional ease, planks can be straight, curved, or angle cut with hand tools.

Specify GRATE-LOCK Grating with Confidence

We have constructed our tables using the most stringent interpretation of the AISI standards. Our safe allowable loads guard against harmful local distortion as well as failure, while other manufacturers have prepared allowable load tables guarding against failure only.

Applications

GRATE-LOCK™ - Ideal for Various Applications

GRATE-LOCK grating and stair treads are stocked in multiple locations in the United States. For the finest in Safety Grating and Stair Treads, contact Cooper B-Line or look for your local GRATE-LOCK grating distributor on the internet using www.cooperblineline.com.



GRATE-LOCK Roof-Top Ramps



GRATE-LOCK Roof-Top Crossovers



GRATE-LOCK Walkway



LAMBDA-LOK Applications

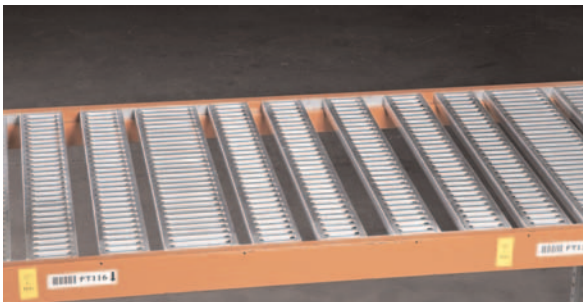

Rack Decks

Recommended Design Practices

1. These specifications are presented as a general guide to the architect or structural engineer in preparing project specifications. Allowable loads, spans and other limiting conditions presented in this catalog offer product data for use in design and construction. These products must not be used without prior structural evaluation by a qualified engineer or architect.
2. All supports should provide a smooth, level, 1½" minimum bearing surface (2½" when using hold-down clip), free of burrs, bridging, welds or other irregularities.
3. Random cut ends and diagonal or circular cut exposed edges should be banded and welded at contact points at the discretion of the design engineer.
4. Bolted connections, except stair or ladder tread attachment to stringer channels, may be replaced by welded connections that develop the same strength.
5. Interlocking panels must be bolted or welded together when kickplates are used.

Architectural Specifications

Part 1: General

- 1.1 Scope** - The contractor shall furnish and install GRATE-LOCK™ Mezzanine Gratings as specified in all areas where shown in the drawings and as specified herein.
- 1.2 Qualifications** - All GRATE-LOCK gratings and accessories, unless otherwise indicated, shall be manufactured by Cooper B-Line, and shall be installed in accordance with its current printed directions.
- 1.3 Submittals** - The contractor shall furnish shop drawings of grating layout, framing and supports, unit dimensions and sections, type and location of fasteners and welds.
- 1.4 Storage and Handling** - All materials shall be stored and handled to avoid damage. Damaged or deteriorated materials shall be removed from the premises.

Part 2: Products

2.1 Grating Materials

- a. **Type:** GRATE-LOCK grating
- b. **Metal:** (carbon steel) (hot dipped, mill-galvanized steel)
- c. **Finish:** (mill-galvanized before fabrication, ASTM A653)
- d. **Metal gauge:** (14-ga. steel) (16-ga./ steel special order), (18-ga. steel)
- e. **Section width:** (12") (9") (6") (3"-4"-supplied FM flange only)
- f. **Channel height:** (1½") (2½") (3") (4")
- g. **Standard Lengths:** 12', 20', 24' (other lengths to order)
- h. **Flange options:** (FM) (MM) (FF)
- i. **Surface condition:** (MG - traction grip) (MS - smooth)

Part 3: Execution

- 3.1 Condition of Surfaces** - Prior to grating installation, contractor shall inspect supports for correct size, layout and alignment and verify that surfaces to relieve grating are free of debris. The contractor shall report to the design or consulting engineer or owner's agent in writing any defects considered detrimental to proper application or grating so defects can be remedied before grating is applied.
- 3.2 Grating Installation** - Install grating in accordance with manufacturer's recommendations and shop drawings. Position grating sections flat and square with ends bearing min. 1½" on supporting structure. Keep grating sections at least ¼" away from vertical steel sections and ½" from concrete walls. Allow clearance at joints between sections of max. ¼" at side channels and max. ⅜" at ends. Band random cut ends and diagonal or circular cut exposed edges with a min. ⅛" thick bar welded at contact points.
- 3.3 Grating Attachment** - Attach grating to supports without warp or deflection as follows:
 - a. **Single plank application** - Secure plank ends to supporting members at every point of contact. Use GRATE-LOCK Anchoring Devices.
 - b. **Multiple plank application** - Secure plank ends to supporting members at every point of contact and intermediate grating sections with at least one attachment each end of plank on alternate sides. For added rigidity, attach side channels of adjacent plank together (at mid-point of span).
 - c. **Welded attachment** - Secure side channels to supports by fusion welding with ⅛" fillet welds 1" long. Weld adjacent planks together with ⅛" fillet welds 1" long, 24" o.c. staggered top and bottom.
 - d. **Clamp and bolt attachment** - Secure intermediate planks to supports using proper length hold-down clamps.

Special Services

Custom Fabrication - On large jobs, Cooper B-Line estimates, quotes, details and fabricates to your specifications. Quotations are made from submitted plans and specification. After receipt of order, a bill of materials and necessary layout drawings are prepared. Grating is supplied with special cutting, banding and toe plates installed where needed. Fabrication services are available through your GRATE-LOCK grating distributor.

Stair Treads - Contact Cooper B-Line at the toll-free number listed below for information on standard and custom stair tread designs.

Distributors - GRATE-LOCK grating for mezzanines are stocked by distributors in principal cities. Consult your local classified telephone directory under GRATE-LOCK or call Cooper B-Line for assistance.

For more information call Cooper B-Line toll free: (800) 851-9341 • FAX (770) 268-7213

NOTICE: We shall not be liable for incidental and consequential damages, directly or indirectly sustained, nor for any loss caused by application of these goods not in accordance with current printed instructions or for other than the intended use. Our liability is expressly limited to replacement of defective goods. Any claim shall be deemed waived unless made in writing to us within thirty (30) days from date it was or reasonably should have been discovered.

Cooper B-Line Safety Grating - Safety for Every Walk of Life

GRATE-LOCK™ System Components

GRATE-LOCK™ Grating Non-Slip Components

Plank Sections

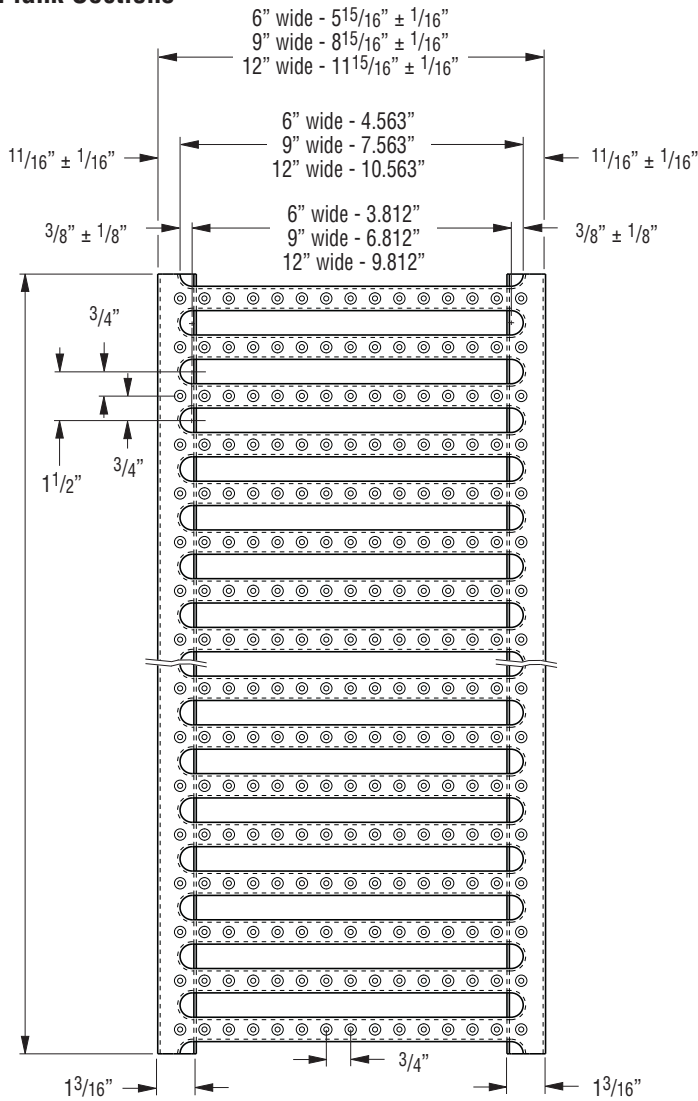

- Widths:** 3", 4"(*), 6", 9", 12"
Heights: 1 1/2"(**), 2 1/2", 3"(*), 4"(*)
Gauges: 18, 16(*), 14
Lengths: 12'-0", 20'-0", 24'-0"
 Other Lengths Available

Note: 3" & 4" filler plank is solid. FM interlock.

- (*) Special quote required.
 (**) The 1 1/2" product is available only in 12'-0" length and differs in side channel detail and loading capabilities. See pages 8 & 9.

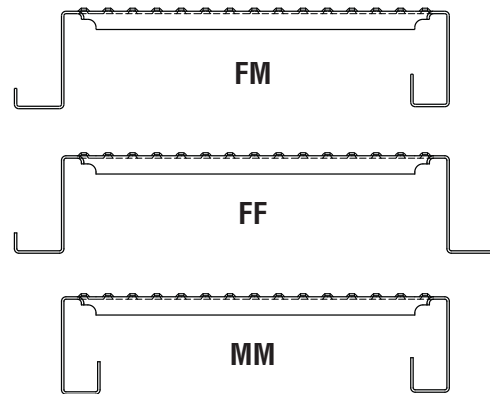

Stair Treads

Stair treads are available in standard and custom designs. Contact Cooper B-Line at (800) 592-3643 for more information.

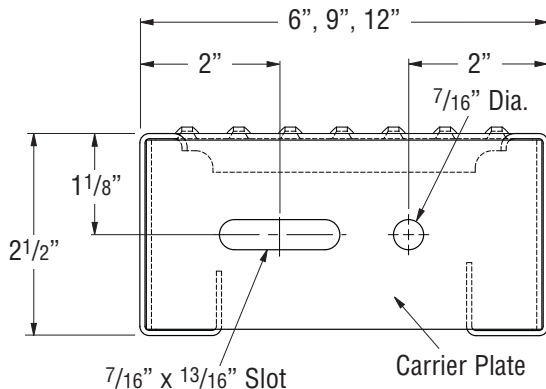

Stair Tread Design and Selection Table

Span	Catalog Number					
	T-MG62514		T-MG92514		T-MG122514	
	U	C	U	C	U	C
2'-0"	3722	1461	2357	974	1276	730
2'-6"	2382	1168	1508	974	816	730
3'-0"	1654	1241	1050	974	783	730
4'-0" (1)	931	931	593	889	442	730

U - Uniform Load (lb/sq. ft) C - Concentrated Load (lb)
 (1) Intermediate stringer recommended for spans over 4

GRATE-LOCK™ System Components

System Components

Item	Product Code	Height
Side kickplate (14 ga.) 12-ft. lengths	M-SK-2514	6½"
	M-SK-3014	7"
	M-SK-4014	8"
End kickplate (14 ga.) 12-ft. lengths	M-EK-2514	6½"
	M-EK-3014	7"
	M-EK-4014	8"
Kickplate clip	M-KC	
Hold-down clamp	M-HC-25	2½"
	M-HC-30	3"
	M-HC-40	4"
	M-HC-15	1½"
J-Bolt	M-250J	5/16 - 2½"
Tap screw (self-drilling)	M-SDST-25	1/4" x 1"
3/8" Hex head bolt with nut and washer	M-100-B	3/8 - 1"

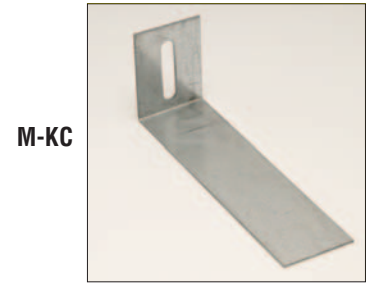

M-KC



M-HC-30



M-250J



M-SDST-25



M-100-B

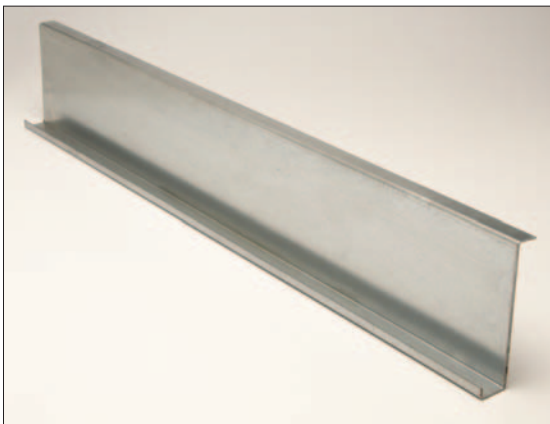

M-SK-3014

How to Specify:

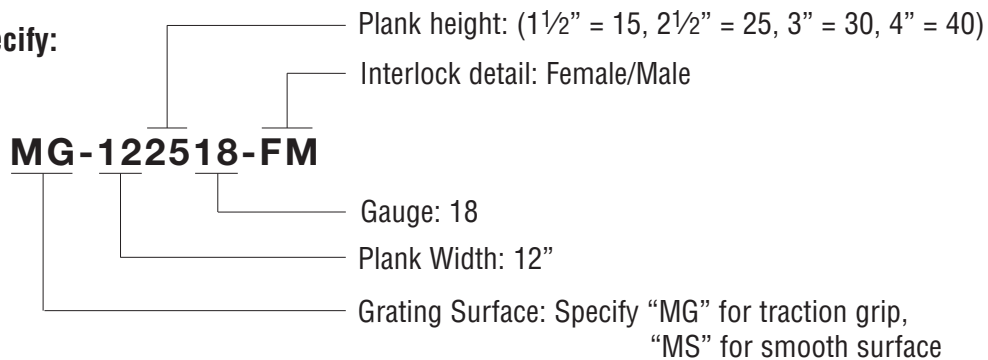

GRATE-LOCK™ Safe Loading Tables

1 1/2" Channel Height — 6", 9", & 12" Widths

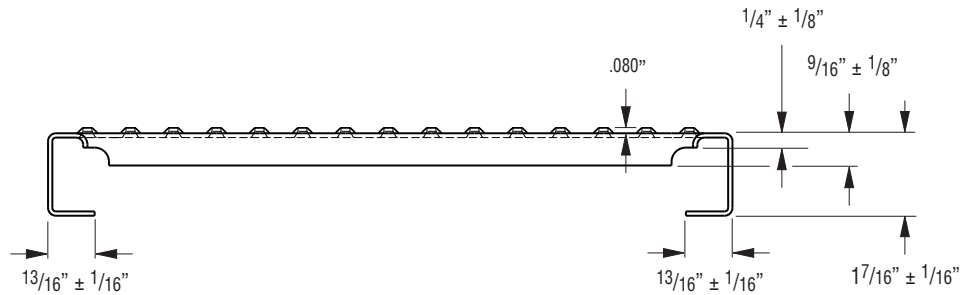

Component Availability of Galvanized Steel Panels Section Description

Interlock Detail	Steel Gauge	Width	Standard Length	Catalog Number (2)	Wt./lin. ft. (lbs.)	Open Area (percent)
(1)	18	12"	12'	MG-121518	2.9	45
		9"		MG-91518	2.3	43
		6"		MG-61518	1.9	39
(1)	16*	12"	12'	MG-121516	3.5	43
		9"		MG-91516	2.9	41
		6"		MG-61516	2.3	37
(1)	14	12"	12'	MG-121514	4.2	40
		9"		MG-91514	3.5	38
		6"		MG-61514	2.7	35

(1) Specify interlock detail of panel, i.e., FM, FF or MM. Refer to general catalog (page 2) for details.

(2) Traction grip surface (MG) is standard. For smooth surface replace "MG" in catalog number with "MS".

Note: Refer to page 6 for information on accessories and 2 1/2", 3" and 4" channel height panels.

* Special Order Only Consult Factory

GRATE-LOCK™ Safe Loading Tables

1 1/2" Channel Height — 6", 9", & 12" Widths

Panel Design Loads

Allowable Loads and Deflections: U=Uniform Load ⁽³⁾ (lb./ft.²) C=Concentrated Load ⁽⁴⁾ (lb.) D=Deflection (in.)

Gauge	Width		Span																					
			2'-0"	2'-6"	3'-0"	3'-6"	4'-0"	4'-6"	5'-0"	5'-6"	6'-0"	6'-6"	7'-0"	7'-6"	8'-0"	8'-6"	9'-0"	9'-6"	10'-0"	10'-6"	11'-0"	11'-6"	12'-0"	
18	12"	U	443	283	196	144	110	87	70	58	49	41	36	31	27	24	21	19	17	16	14	13	12	
		D	.10	.11	.14	.18	.22	.27	.33	.40	.48	.56	.65	.74	.84	.95	1.06	1.18	1.31	1.45	1.59	1.73	1.89	
		C																						
		D																						
		9"	U	591	378	263	193	147	116	94	78	65	56	48	42	37	32	29	26	23	21	19	17	16
			D	.10	.11	.14	.18	.22	.27	.33	.40	.48	.56	.65	.74	.84	.95	1.06	1.18	1.31	1.45	1.59	1.73	1.89
	C		440	352	293	251	220	195	176	160	146	135	125	117	110	103	97	92	86	83	80	76	73	
	D		.04	.07	.10	.13	.17	.21	.26	.32	.38	.45	.52	.60	.68	.77	.86	.96	1.06	1.17	1.28	1.40	1.54	
	6"		U	890	570	395	290	222	175	142	117	99	84	72	63	55	49	44	39	35	32	29	26	24
			D	.10	.11	.14	.18	.22	.27	.33	.40	.48	.56	.65	.74	.84	.95	1.06	1.18	1.31	1.45	1.59	1.73	1.89
		C																						
		D																						
16*		12"	U	549	351	244	179	137	108	87	72	61	52	44	39	34	30	27	24	22	19	18	16	15
			D	.10	.11	.14	.18	.22	.27	.33	.40	.48	.56	.65	.74	.84	.95	1.06	1.18	1.31	1.45	1.59	1.73	1.89
	C																							
	D																							
	9"		U	733	469	326	239	183	144	117	97	81	69	59	52	45	40	36	32	29	26	24	22	20
			D	.10	.11	.14	.18	.22	.27	.33	.40	.48	.56	.65	.74	.84	.95	1.06	1.18	1.31	1.45	1.59	1.73	1.89
		C	546	437	364	312	273	242	218	198	182	168	156	145	136	128	121	115	109	104	99	95	91	
		D	.04	.07	.10	.13	.17	.21	.26	.32	.38	.45	.52	.60	.68	.77	.86	.96	1.06	1.17	1.28	1.40	1.54	
		6"	U	1104	706	490	360	276	218	176	146	122	104	90	78	69	61	54	49	44	40	36	33	30
			D	.10	.11	.14	.18	.22	.27	.33	.40	.48	.56	.65	.74	.84	.95	1.06	1.18	1.31	1.45	1.59	1.73	1.89
	C																							
	D																							
14	12"		U	667	427	296	217	166	131	106	88	74	63	54	47	41	36	32	29	26	24	22	20	18
			D	.10	.11	.14	.18	.22	.27	.33	.40	.48	.56	.65	.74	.84	.95	1.06	1.18	1.31	1.45	1.59	1.73	1.89
		C																						
		D																						
		9"	U	891	570	396	291	222	176	142	117	99	84	72	63	55	49	44	39	35	32	29	27	24
			D	.10	.11	.14	.18	.22	.27	.33	.40	.48	.56	.65	.74	.84	.95	1.06	1.18	1.31	1.45	1.59	1.73	1.89
	C		663	531	442	379	331	295	265	241	221	204	189	177	165	156	147	139	132	126	120	115	110	
	D		.04	.07	.10	.13	.17	.21	.26	.32	.38	.45	.52	.60	.68	.77	.86	.96	1.06	1.17	1.28	1.40	1.54	
	6"		U	1341	858	596	438	335	265	214	177	149	127	109	95	83	74	66	59	53	48	44	40	37
			D	.10	.11	.14	.18	.22	.27	.33	.40	.48	.56	.65	.74	.84	.95	1.06	1.18	1.31	1.45	1.59	1.73	1.89
		C																						
		D																						

⁽³⁾ Simple or equal-length double spans; multiply uniform load values by 1.07 for three, or 1.04 for four equal-length continuous spans. Deflections shown for simple spans (all were within 1/120th of span limitation); multiply deflection values by 0.71 for equal-length double spans, or by 0.76 for three or four equal-length continuous spans.

⁽⁴⁾ Simple spans; multiply concentrated load volumes by 1.23 for equal-length double spans, 1.17 for three, or 1.19 for four equal length continuous spans. Load(s) applied to top section, as a line across entire section width, at center of (each) span.

* Special Order Only Consult Factory

GRATE-LOCK™ Safe Loading Tables

2 1/2" Channel Height — 6", 9", & 12" Widths

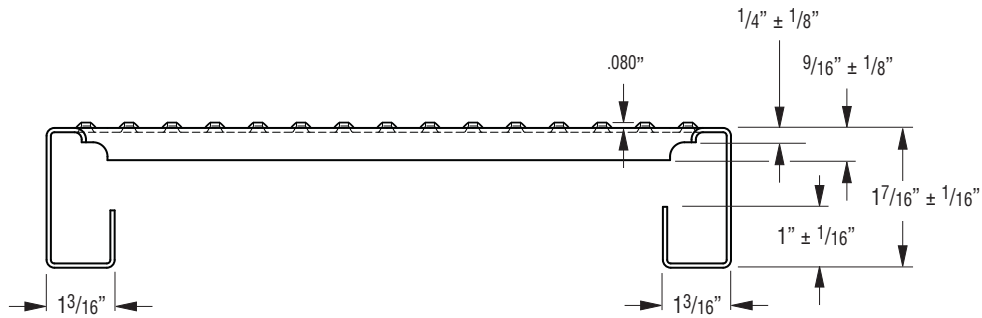

Component Availability/Galvanized Steel Panels Section Description

Interlock Detail	Steel Gauge	Width	Standard Length	Catalog Number (2)	Wt./lin. ft. (lbs.)	Open Area (percent)
(1)	18	12"	12'	MG-122518	3.5	45
		9"		MG-92518	3.0	43
		6"		MG-62518	2.5	39
(1)	16*	12"	12'	MG-122516	4.3	43
		9"		MG-92516	3.7	41
		6"		MG-62516	3.1	37
(1)	14	12"	12'	MG-122514	5.2	40
		9"		MG-92514	4.4	38
		6"		MG-62514	3.7	35

(1) Specify interlock detail of panel, i.e., FM, FF or MM. Refer to general catalog (page 2) for details.

(2) Traction grip surface (MG) is standard. For smooth surface replace "MG" in catalog number with "MS".

Note: Refer to page 7 for information on accessories.

* Special Order Only Consult Factory

GRATE-LOCK™ Safe Loading Tables

2 1/2" Channel Height — 6", 9", & 12" Widths

Product Selection/Design Table

Allowable Loads and Deflections: U=Uniform Load (lb./ft.²) C=Concentrated Load (lb.) D=Deflection (in.)

Gauge	Width	Weight Lb./lin.ft.	Cat. No.	Load Type	Clear Span (Lin.Ft.)																	
					2'-0"	3'-0"	4'-0"	5'-0"	6'-0"	7'-0"	8'-0"	9'-0"	10'-0"	11'-0"	12'-0"	13'-0"	14'-0"	15'-0"	16'-0"	17'-0"	18'-0"	
18	12"	3.70	MG122518	U	1057	552	312	200	140	103	80	64	52	43	36	31	27	23	20	18	16	
				D	0.03	0.10	0.17	0.27	0.39	0.54	0.71	0.90	1.13	1.38	1.61	1.91	2.23	2.47	2.83	3.20	3.60	
				C	529	529	529	501	420	362	319	286	260	239	217	207	194	184	175	167	160	
				D	0.01	0.05	0.12	0.22	0.31	0.43	0.57	0.72	0.90	1.09	1.33	1.57	1.85	2.15	2.48	2.85	3.24	
	9"	3.16	MG92518	U	1552	691	390	251	175	129	100	79	65	54	46	40	35	30	27	24	21	
				D	0.05	0.10	0.18	0.28	0.41	0.56	0.74	0.95	1.18	1.44	1.73	2.05	2.41	2.80	3.22	3.69	4.01	
				C	705	705	585	470	394	339	299	268	243	223	207	193	181	171	163	153	145	
				D	0.02	0.07	0.14	0.23	0.33	0.45	0.59	0.76	0.94	1.15	1.38	1.64	1.93	2.24	2.58	2.91	3.27	
	6"	2.62	MG62518	U	2141	954	538	346	241	178	137	109	89	74	63	54	47	42	37	33	30	
				D	0.04	0.09	0.16	0.25	0.36	0.50	0.65	0.83	1.04	1.27	1.52	1.80	2.11	2.45	2.82	3.23	3.67	
				C	1053	715	538	432	362	312	274	246	223	204	189	176	165	156	148	141	135	
				D	0.04	0.07	0.13	0.20	0.29	0.40	0.52	0.67	0.83	1.01	1.22	1.44	1.69	1.96	2.26	2.58	2.93	
16*	12"	4.55	MG122516	U	1276	655	370	238	166	123	95	76	62	52	44	37	32	28	24	22	20	
				D	0.03	0.10	0.17	0.27	0.39	0.54	0.71	0.91	1.13	1.39	1.67	1.94	2.21	2.55	2.81	3.34	3.59	
				C	638	638	638	595	499	432	381	342	312	285	261	241	224	209	196	184	174	
				D	0.01	0.05	0.12	0.22	0.31	0.43	0.57	0.72	0.91	1.10	1.31	1.53	1.78	2.04	2.34	2.63	2.94	
	9"	3.89	MG92516	U	1949	869	491	316	220	163	126	100	82	69	58	49	43	37	33	29	26	
				D	0.05	0.10	0.18	0.29	0.41	0.57	0.75	0.96	1.19	1.46	1.76	2.05	2.39	2.69	3.16	3.48	3.92	
				C	851	851	736	592	496	428	378	339	308	283	261	241	224	209	196	184	174	
				D	0.02	0.09	0.15	0.23	0.33	0.45	0.60	0.76	0.95	1.17	1.40	1.64	1.90	2.19	2.48	2.77	3.15	
	6"	3.22	MG62516	U	2774	1235	696	447	312	230	177	140	114	95	81	69	60	53	47	42	38	
				D	0.04	0.09	0.17	0.26	0.38	0.51	0.67	0.86	1.06	1.30	1.55	1.84	2.15	2.49	2.86	3.26	3.69	
				C	1134	926	696	559	467	402	354	316	286	262	242	225	211	198	188	178	170	
				D	0.02	0.07	0.13	0.21	0.30	0.41	0.54	0.69	0.85	1.04	1.24	1.47	1.72	1.99	2.29	2.61	2.95	
14	12"	5.62	MG122514	U	1276	783	442	284	199	147	113	90	74	62	52	44	38	35	29	28	25	
				D	0.03	0.10	0.17	0.27	0.39	0.54	0.71	0.91	1.13	1.38	1.63	1.94	2.20	2.70	2.92	3.58	4.08	
				C	730	730	730	711	596	514	454	407	370	338	310	286	266	248	233	219	207	
				D	0.01	0.05	0.12	0.22	0.31	0.43	0.57	0.72	0.90	1.09	1.31	1.53	1.77	2.04	2.33	2.63	2.96	
	9"	4.80	MG92514	U	2357	1050	593	381	266	196	151	121	98	82	70	58	50	45	40	36	32	
				D	0.04	0.10	0.18	0.28	0.41	0.56	0.74	0.94	1.17	1.43	1.72	1.88	2.21	2.57	2.96	3.39	3.85	
				C	974	974	889	714	598	516	454	407	369	339	314	282	265	250	238	227	218	
				D	0.02	0.07	0.14	0.23	0.33	0.45	0.59	0.75	0.94	1.14	1.38	1.50	1.77	2.05	2.37	2.71	3.08	
	6"	3.98	MG62514	U	3722	1654	931	596	414	304	233	184	149	123	103	88	76	66	58	52	46	
				D	0.05	0.10	0.18	0.29	0.42	0.56	0.74	0.93	1.15	1.39	1.65	1.93	2.25	2.57	2.91	3.32	3.70	
				C	1461	1241	931	744	620	532	465	414	372	338	310	286	266	248	233	219	207	
				D	0.03	0.09	0.14	0.23	0.33	0.45	0.58	0.74	0.92	1.11	1.32	1.55	1.80	2.06	2.36	2.65	2.98	

Notes:

These tables are prepared based on test conducted in accordance with the 1980 edition, section 6.2 of the American Iron and Steel Institute Specification for the design of cold-rolled steel structural members with results checked and adjusted where required by calculations in accordance with section 2 of the same specification.

Safe Allowable Loads with deflections equal to or less than L/120

Safe Allowable Loads with deflections equal to or less than L/240

*Special Order Only Consult Factory

GRATE-LOCK™ Safe Loading Tables

3" Channel Height — 6", 9", & 12" Widths

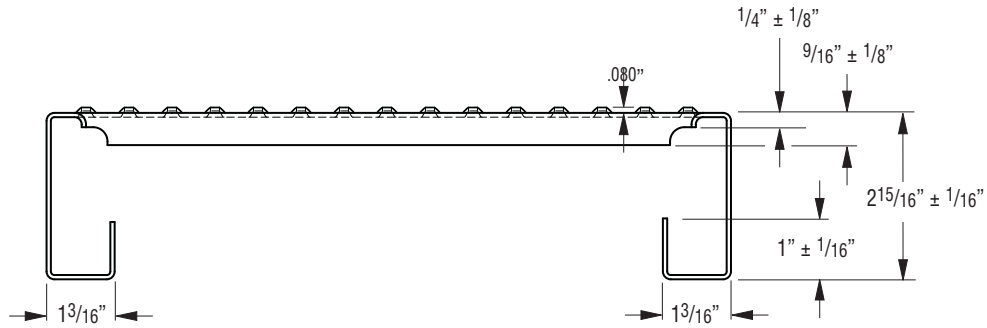

Component Availability of Galvanized Steel Panels Section Description

Interlock Detail	Steel Gauge	Width	Standard Length	Catalog Number (2)	Wt./lin. ft. (lbs.)	Open Area (percent)
(1)	18	12"	12'	MG-123018	3.6	45
		9"		MG-93018	3.1	43
		6"		MG-63018	2.6	39
(1)	16*	12"	12'	MG-123016	4.5	43
		9"		MG-93016	3.7	41
		6"		MG-63016	3.2	37
(1)	14	12"	12'	MG-123014	5.4	40
		9"		MG-93014	4.7	38
		6"		MG-63014	3.9	35

(1) Specify interlock detail of panel, i.e., FM, FF or MM. Refer to general catalog (page 2) for details.

(2) Traction grip surface (MG) is standard. For smooth surface replace "MG" in catalog number with "MS".

Note: Refer to page 7 for information on accessories.

* Special Order Only Consult Factory

GRATE-LOCK™ Safe Loading Tables

3" Channel Height — 6", 9", & 12" Widths

Product Selection/Design Table

Allowable Loads and Deflections: U=Uniform Load (lb./ft.²) C=Concentrated Load (lb.) D=Deflection (in.)

Gauge	Width	Weight Lb./lin.ft.	Cat. No.	Load Type	Clear Span (Lin.Ft.)																	
					2'-0"	3'-0"	4'-0"	5'-0"	6'-0"	7'-0"	8'-0"	9'-0"	10'-0"	11'-0"	12'-0"	13'-0"	14'-0"	15'-0"	16'-0"	17'-0"	18'-0"	
18	12"	3.88	MG123018	U	1057	611	345	222	155	114	88	70	57	48	41	35	31	27	24	22	20	
				D	0.02	0.07	0.12	0.19	0.28	0.39	0.51	0.65	0.80	0.98	1.20	1.43	1.68	1.95	2.25	2.58	2.93	
				C	529	529	529	529	472	405	354	316	287	263	244	229	215	203	193	184	177	
				D	0.01	0.03	0.07	0.14	0.22	0.31	0.41	0.52	0.64	0.79	0.95	1.14	1.34	1.56	1.80	2.06	2.34	
				U	1881	840	472	302	210	154	118	93	76	62	52	45	39	34	30	26	24	
				D	0.03	0.08	0.13	0.21	0.31	0.42	0.55	0.68	0.86	1.01	1.21	1.43	1.70	1.93	2.23	2.47	2.81	
	9"	3.34	MG93018	C	705	705	705	567	472	405	354	315	283	258	236	218	202	189	177	168	161	
				D	0.01	0.04	0.11	0.17	0.24	0.33	0.44	0.55	0.68	0.82	0.98	1.15	1.32	1.52	1.74	1.97	2.24	
				U	2834	1260	709	453	315	231	177	140	113	94	79	67	58	50	44	39	35	
				D	0.04	0.07	0.13	0.21	0.29	0.39	0.52	0.66	0.80	0.99	1.19	1.37	1.14	1.82	2.08	2.34	2.60	
				C	1058	945	709	567	472	405	354	315	283	258	236	218	202	189	177	167	157	
				D	0.02	0.06	0.11	0.16	0.23	0.32	0.42	0.53	0.65	0.60	0.93	1.11	1.28	1.47	1.66	1.14	2.09	
16*	12"	4.77	MG123016	U	1276	775	438	282	197	160	123	98	80	66	56	45	39	35	31	28	25	
				D	0.02	0.07	0.12	0.20	0.28	0.45	0.59	0.75	0.93	1.13	1.35	1.43	1.69	1.96	2.27	2.61	2.97	
				C	638	638	638	638	591	559	492	440	398	365	337	293	276	262	249	238	229	
				D	0.01	0.03	0.07	0.05	0.23	0.36	0.47	0.60	0.74	0.90	1.08	1.15	1.35	1.57	1.82	2.09	2.38	
				U	2275	1029	581	373	261	193	149	118	97	81	69	59	52	46	40	36	33	
				D	0.03	0.03	0.13	0.21	0.30	0.41	0.54	0.69	0.87	1.06	1.27	1.51	1.77	2.06	2.37	2.70	3.05	
	9"	4.11	MG93016	C	851	851	851	700	587	506	446	400	363	333	309	288	271	256	242	230	220	
				D	0.01	0.04	0.11	0.17	0.24	0.33	0.44	0.56	0.69	0.85	1.02	1.21	1.42	1.65	1.89	2.16	2.44	
				U	3418	1519	854	547	380	279	214	169	137	113	95	82	71	62	55	49	45	
				D	0.03	0.07	0.12	0.20	0.28	0.39	0.50	0.64	0.79	0.95	1.13	1.34	1.56	1.81	2.08	2.37	2.68	
				C	1134	1134	854	684	570	480	427	380	342	310	286	266	249	234	221	210	201	
				D	0.02	0.05	0.10	0.15	0.23	0.31	0.40	0.51	0.63	0.76	0.91	1.07	1.25	1.45	1.66	1.89	2.14	
14	12"	5.89	MG123014	U	1461	950	536	345	241	178	137	109	89	74	63	54	47	42	37	33	30	
				D	0.02	0.07	0.13	0.20	0.29	0.40	0.53	0.67	0.84	1.02	1.23	1.46	1.71	1.99	2.29	2.62	2.98	
				C	730	730	730	730	722	622	548	491	446	409	379	353	332	314	298	284	272	
				D	0.01	0.03	0.07	0.14	0.23	0.32	0.42	0.54	0.67	0.82	0.98	1.17	1.37	1.59	1.83	2.10	2.38	
				U	2597	1477	831	532	369	271	208	164	133	110	92	79	68	59	52	46	41	
				D	0.03	0.09	0.16	0.25	0.36	0.48	0.63	0.79	0.98	1.19	1.40	1.67	1.94	2.18	2.53	2.81	3.14	
	9"	5.07	MG93014	C	974	974	974	974	831	712	623	554	498	453	415	383	356	332	311	293	277	
				D	0.01	0.04	0.10	0.20	0.28	0.38	0.50	0.63	0.78	0.95	1.12	1.32	1.54	1.76	2.00	2.27	2.54	
				U	4984	2215	1246	797	554	407	311	246	199	165	138	118	102	89	78	69	62	
				D	0.04	0.09	0.15	0.24	0.34	0.46	0.60	0.76	0.94	1.14	1.35	1.60	1.85	2.12	2.42	2.72	3.05	
				C	1461	1461	1246	997	831	712	623	554	498	453	415	383	356	332	311	293	277	
				D	0.02	0.06	0.12	0.19	0.27	0.36	0.48	0.61	0.75	0.91	1.08	1.27	1.48	1.70	1.92	2.18	2.43	

Notes:

These tables are prepared based on test conducted in accordance with the 1980 edition, section 6.2 of the American Iron and Steel Institute Specification for the design of cold-rolled steel structural members with results checked and adjusted where required by calculations in accordance with section 2 of the same specification.

Safe Allowable Loads with deflections equal to or less than L/120

Safe Allowable Loads with deflections equal to or less than L/240

*Special Order Only Consult Factory

GRATE-LOCK™ Safe Loading Tables

4" Channel Height — 6", 9", & 12" Widths

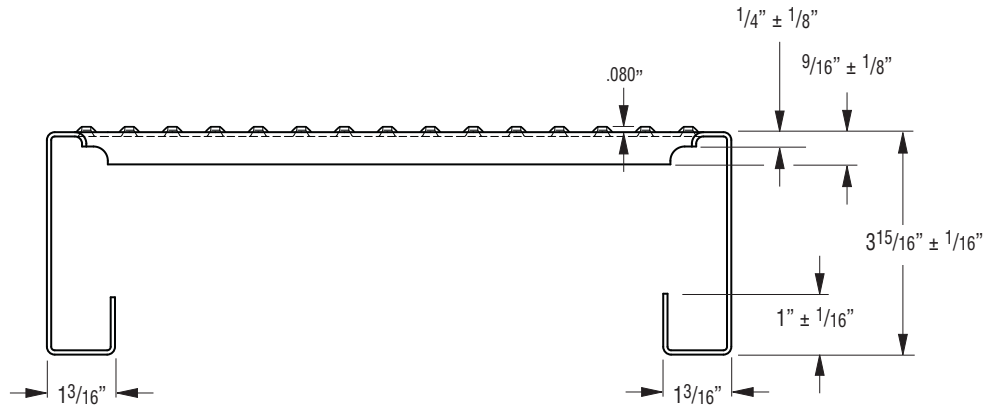

Component Availability of Galvanized Steel Panels Section Description

Interlock Detail	Steel Gauge	Width	Standard Length	Catalog Number (2)	Wt./lin. ft. (lbs.)	Open Area (percent)
(1)	18	12"	12'	MG-124018	4.0	45
		9"		MG-94018	3.5	43
		6"		MG-64018	3.0	39
(1)	16*	12"	12'	MG-124016	4.9	43
		9"		MG-94016	4.3	41
		6"		MG-64016	3.7	37
(1)	14	12"	12'	MG-124014	5.9	40
		9"		MG-94014	5.2	38
		6"		MG-64014	4.4	35

(1) Specify interlock detail of panel, i.e., FM, FF or MM. Refer to general catalog (page 2) for details.

(2) Traction grip surface (MG) is standard. For smooth surface replace "MG" in catalog number with "MS".

Note: Refer to page 7 for information on accessories.

* Special Order Only Consult Factory



GRATE-LOCK™ Safe Loading Tables

4" Channel Height — 6", 9", & 12" Widths

Product Selection/Design Table

Allowable Loads and Deflections: U=Uniform Load (lb./ft.²) C=Concentrated Load (lb.) D=Deflection (in.)

Gauge	Width	Weight Lb./lin.ft.	Cat. No.	Load Type	Clear Span (Lin.Ft.)																	
					2'-0"	3'-0"	4'-0"	5'-0"	6'-0"	7'-0"	8'-0"	9'-0"	10'-0"	11'-0"	12'-0"	13'-0"	14'-0"	15'-0"	16'-0"	17'-0"	18'-0"	
18	12"	4.24	MG124018	U	1057	996	560	359	249	183	140	111	90	74	62	53	46	40	35	31	28	
				D	0.03	0.06	0.11	0.16	0.24	0.34	0.42	0.54	0.66	0.81	0.96	1.09	1.26	1.45	1.65	1.90	2.11	
				C	529	529	529	529	529	529	529	498	448	408	374	345	320	299	280	264	249	
				D	0.00	0.01	0.04	0.08	0.13	0.21	0.32	0.44	0.53	0.65	0.77	0.87	1.01	1.17	1.33	1.50	1.68	
	9"	3.70	MG94018	U	1881	1329	747	478	332	244	187	148	120	99	83	71	61	53	47	41	37	
				D	0.02	0.06	0.12	0.18	0.26	0.35	0.47	0.58	0.72	0.86	1.03	1.21	1.41	1.60	1.83	2.05	2.34	
				C	705	705	705	705	705	641	560	498	448	408	374	345	320	299	280	264	249	
				D	0.01	0.02	0.06	0.12	0.20	0.28	0.36	0.46	0.57	0.70	0.83	0.96	1.12	1.28	1.47	1.65	1.85	
	6"	3.16	MG64018	U	4232	1993	1121	717	498	366	280	221	179	148	125	106	92	80	70	62	55	
				D	0.03	0.06	0.10	0.18	0.25	0.34	0.44	0.55	0.69	0.83	0.99	1.17	1.35	1.54	1.77	1.98	2.24	
				C	1058	1058	1058	897	747	641	560	498	448	408	374	345	320	299	280	264	249	
				D	0.01	0.04	0.08	0.13	0.19	0.26	0.35	0.45	0.55	0.67	0.80	0.93	1.07	1.24	1.41	1.60	1.78	
16*	12"	5.21	MG124016	U	1276	1215	685	439	306	226	173	138	112	93	79	69	60	53	47	42	37	
				D	0.03	0.06	0.11	0.17	0.25	0.34	0.45	0.51	0.71	0.86	1.03	1.11	1.29	1.49	1.71	1.95	2.20	
				C	638	638	638	638	638	638	638	619	560	512	472	450	420	395	373	354	337	
				D	0.00	0.01	0.04	0.08	0.14	0.21	0.33	0.46	0.57	0.69	0.83	0.89	1.03	1.20	1.37	1.56	1.76	
	9"	4.55	MG94016	U	2275	1612	907	580	403	296	227	179	145	120	101	86	75	66	58	52	47	
				D	0.02	0.06	0.10	0.16	0.24	0.37	0.48	0.60	0.75	0.91	1.07	1.27	1.48	1.71	1.96	2.22	2.51	
				C	851	851	851	851	851	777	680	604	544	495	453	420	393	369	348	330	314	
				D	0.01	0.02	0.05	0.10	0.18	0.29	0.38	0.49	0.60	0.73	0.86	1.01	1.18	1.37	1.56	1.78	2.01	
	6"	3.89	MG64016	U	5118	2418	1360	870	604	444	340	269	218	180	151	129	111	97	85	75	67	
				D	0.02	0.06	0.10	0.16	0.22	0.30	0.40	0.51	0.63	0.76	0.90	1.05	1.22	1.41	1.59	1.80	2.02	
				C	1134	1134	1134	1088	907	777	680	604	544	495	453	418	389	363	340	320	302	
				D	0.01	0.03	0.07	0.12	0.18	0.25	0.32	0.41	0.50	0.60	0.72	0.85	0.98	1.13	1.28	1.44	1.61	
14	12"	6.49	MG124014	U	1461	1448	814	521	362	266	204	161	131	109	92	79	69	61	54	48	43	
				D	0.01	0.06	0.10	0.16	0.24	0.32	0.42	0.54	0.67	0.82	0.98	1.16	1.35	1.57	1.80	2.06	2.33	
				C	730	730	730	730	730	730	730	724	655	599	554	515	483	455	430	409	391	
				D	0.00	0.01	0.04	0.07	0.12	0.20	0.30	0.43	0.54	0.65	0.78	0.93	1.08	1.26	1.44	1.65	1.87	
	9"	5.62	MG94014	U	2597	1988	1120	719	501	369	284	225	184	153	129	111	96	84	75	67	60	
				D	0.02	0.06	0.11	0.17	0.25	0.34	0.44	0.57	0.70	0.85	0.92	1.21	1.41	1.63	1.88	2.14	2.42	
				C	974	974	974	974	974	969	852	761	688	629	581	540	505	475	449	426	406	
				D	0.01	0.02	0.05	0.10	0.17	0.27	0.36	0.45	0.56	0.68	0.82	0.97	1.13	1.31	1.50	1.71	1.93	
	6"	4.80	MG64014	U	5843	2895	1629	1042	724	532	407	322	261	215	181	154	133	116	102	91	82	
				D	0.03	0.06	0.12	0.19	0.28	0.37	0.48	0.61	0.75	0.91	1.08	1.26	1.47	1.69	1.92	2.19	2.48	
				C	1461	1461	1461	1303	1086	931	814	724	651	592	513	501	465	434	407	386	367	
				D	0.01	0.04	0.09	0.15	0.21	0.30	0.39	0.49	0.60	0.73	0.87	1.01	1.18	1.35	1.54	1.75	1.98	

Notes:

These tables are prepared based on test conducted in accordance with the 1980 edition, section 6.2 of the American Iron and Steel Institute Specification for the design of cold-rolled steel structural members with results checked and adjusted where required by calculations in accordance with section 2 of the same specification.

Safe Allowable Loads with deflections equal to or less than L/120

Safe Allowable Loads with deflections equal to or less than L/240

*Special Order Only Consult Factory

Solid Deck Planking

Solid deck planking provides the flexibility of a medium weight and a smooth surface. Manufactured with the same interlocking system of GRATE-LOCK™, Solid deck locks into place for quick installation. Use Solid deck in areas where a solid, sturdy covering surface is needed. Available in a wide variety of gauges and special quote options.

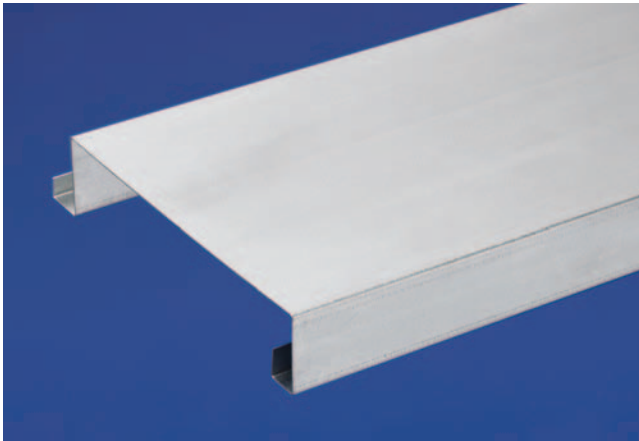

Solid Deck Planking Features

- Durable, pre-galvanized solid surface
- Quick, low-cost installation
- Easy to replace
- Minimum maintenance
- Accessories available
- Applications include rack decking, filler planks, and light-load flooring
- Other gauges, widths, and lengths are available by special order. On large jobs, Cooper B-Line estimates, details, and fabricates to your specifications.
- Available in widths of 6", 9", and 12"
- Available in heights of 1½" and 2½"
- Available in lengths of 12'-0", 20'-0", 24'-0"
- Standard 14 gauge steel

How to Specify:

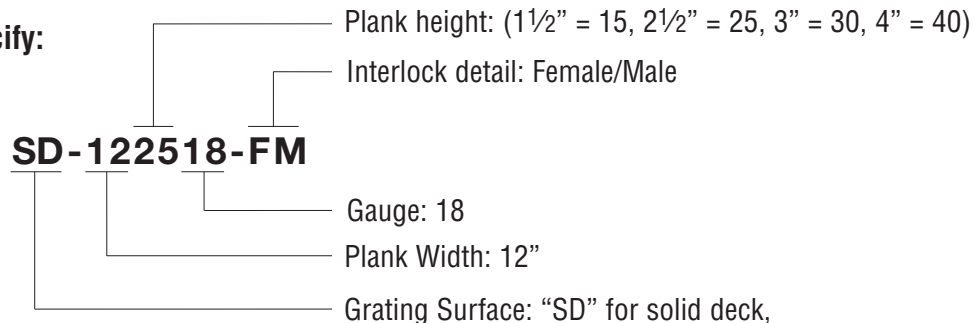

Solid Deck Planking

** Profile for 1 1/2" Channel Depth

Interlocking Options for 2 1/2" Channel Depth

Specify interlock detail of panel, i.e., FM, FF or MM. Refer to general catalog (page 2) for details

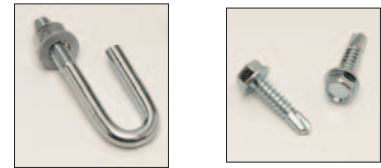
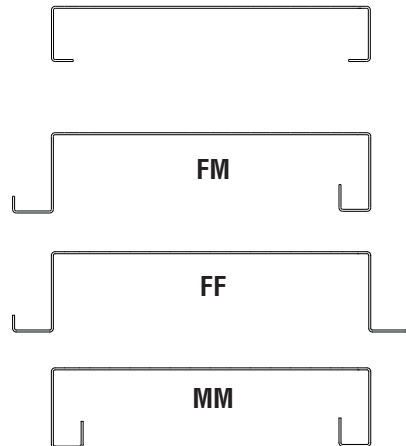

Standard Accessories

Channel Depth	Gauge	Width	Catalog Number	Weight Lb./lin.ft.	Load Type	Clear Span (Lin.Ft.)										
						2'-0"	3'-0"	4'-0"	5'-0"	6'-0"	7'-0"	8'-0"	9'-0"	10'-0"	11'-0"	12'-0"
1 1/2" **	14	12"	SD-121514	4.5	U	316	296	166	106	74	54	41	32	26	22	18
					D	0.03	0.14	0.22	0.33	0.48	0.65	0.84	1.06	1.31	1.59	1.89
		9"	SD-91514	3.7	U	420	398	222	142	99	72	55	44	35	29	24
					D	0.03	0.14	0.22	0.33	0.48	0.65	0.85	1.06	1.31	1.59	1.89
		6"	SD-61514	2.9	U	690	596	335	214	149	109	83	66	53	44	37
					D	0.03	0.06	0.10	0.18	0.25	0.34	0.44	0.55	0.69	0.83	0.99
2 1/2"	14	12"	SD-122514	5.8	U	316	316	316	284	199	147	113	90	74	62	52
					D	0.01	0.04	0.13	0.27	0.39	0.54	0.71	0.91	1.13	1.38	1.63
		9"	SD-92514	5.0	U	420	420	420	381	266	196	151	121	98	82	70
					D	0.01	0.04	0.13	0.28	0.41	0.56	0.74	0.94	1.17	1.43	1.72
		6"	SD-62514	4.2	U	690	690	690	596	414	304	233	184	149	123	103
					D	0.01	0.04	0.14	0.29	0.42	0.56	0.74	0.93	1.15	1.39	1.65
6"	SD-62514	4.2	C	344	344	344	344	344	344	344	344	344	344	338	310	
			D	0.01	0.02	0.05	0.11	0.18	0.29	0.43	0.62	0.85	1.11	1.32		

Notes:

These tables are prepared based on tests conducted in accordance with the 1986 edition, section F.1 of the American Iron and Steel Institute Specification for the design of cold-rolled steel structural members with the results checked and adjusted where required by calculations in accordance with section A5 of the same specification.

 Safe Allowable Loads with deflections equal to or less than L/120

 Safe Allowable Loads with deflections equal to or less than L/240

Bold Print values designate loads/deflections limited due to 'Strut Loading'

U = Allowable Simple Span Uniform Load (lb./ft.²) C = Allowable Simple Span Concentrated Line Load (lb.) at Midspan

D = Vertical Deflection (in.) at Midspan

LAMBDA-LOK™ - Solid Mezzanine & Industrial Flooring

LAMBDA-LOK is a solid steel plank flooring that does not duplicate conventional grating. It is no longer necessary to have slots and holes for reinforcing the top surface that prohibit wheel use on elevated or mezzanine floors. Small wheels roll freely on LAMBDA-LOK's strong ribbed surface.

The load bearing lok will lock the solid steel planks together without the need for nuts, bolts, or crimping tools by twisting into place with pliers. Patented, positive attachment, holds planks in place, and provide an "unlocking" feature for later removal or replacement.

Fast Installation

Male/male planks assemble fast and can be spliced anywhere, even in the field, and require fewer support members. See chart on page 19.

LAMBDA-LOK Application



View from below



View from above

LAMBDA-LOK Features

- Designed for carts and two wheelers (not recommended for pallet movers)
- Simple low-cost installation - no nuts or bolts! Twist into place with a pliers
- Will handle heavy loads over long spans
- Durable, pre-galvanized surface with minimum maintenance
- Extra load bearing loks can be added for concentrated loads
- Easy to replace if section is damaged
- Applications include mezzanines, catwalks, sub-floors, walkways, and inverted ceilings

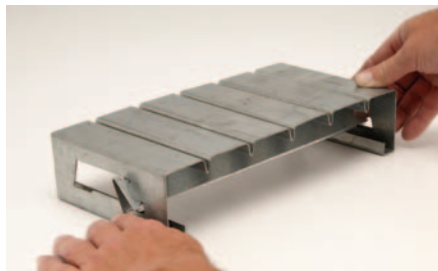

LAMBDA-LOK™ - Solid Mezzanine & Industrial Flooring

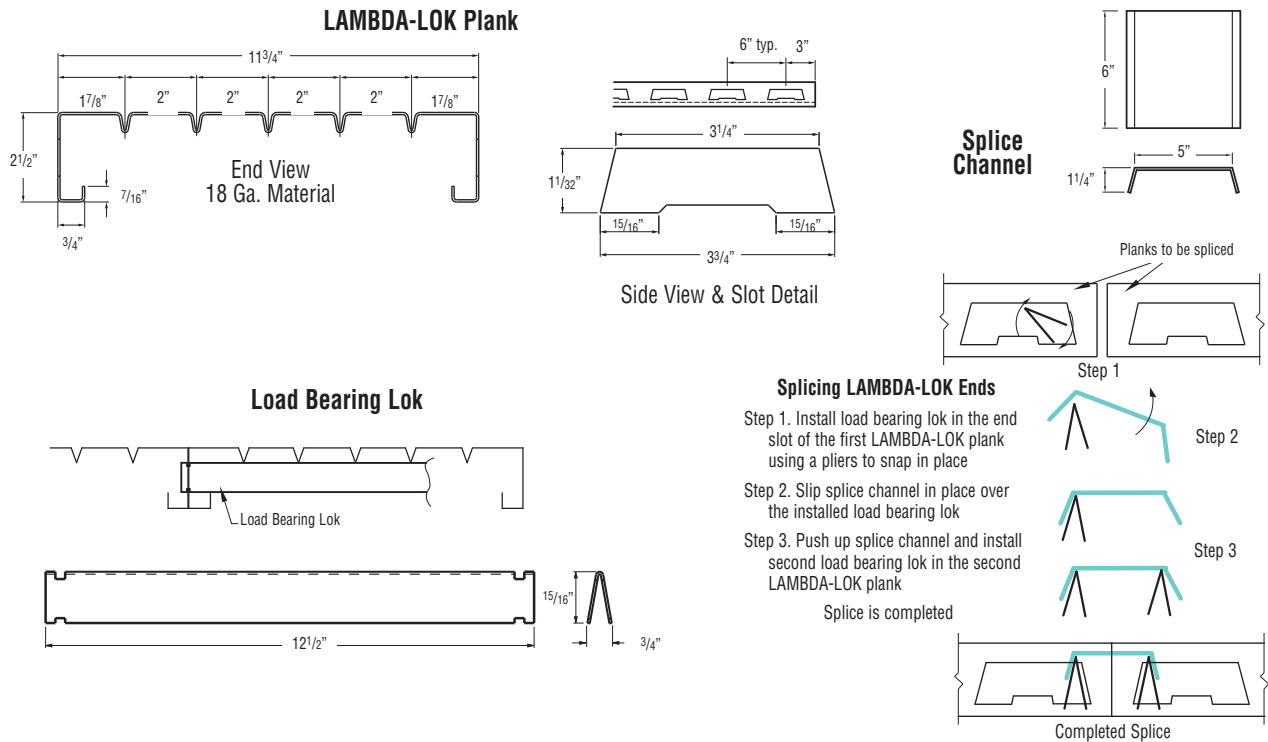

Allowable Load Capacities (Safety Factor 1.5)

Span	2'-0"	3'-0"	4'-0"	5'-0"	6'-0"	7'-0"	8'-0"
C	1604	1069	802	642	535	458	401
D_c	.03	.07	.12	.18	.26	.36	.45
W (Wheel)	300	300	300	300	256	219	192
U	1637	728	409	262	182	134	102
D_u	.01	.08	.15	.23	.33	.45	.58

Notes

U - Allowable Uniform Load (lbs./sq.ft.)

C - Allowable Concentrated Line Load at Midspan (lbs.)

D - Deflection at Midspan (in.)

W - Allowable Wheel Load Simulated by a 1 1/2" x 1" Point Load at Mid-Width and Midspan (lbs.)

LAMBDA-LOK Spacing

Spacing should be 12" on center for most applications

Splicing Conditions

To maintain allowable loads when splicing, the following conditions must be met:

1. Outer most panels must be spliced at supports only
2. Inner panels can be spliced anywhere, including midspan, providing the distance between splices/connections of adjacent panels equals or exceeds the support spacing

Global Locations

Cooper B-Line's U.S. Customer Service Center is staffed Monday through Friday from 7 a.m. to 5:00 p.m. Central Standard Time. If a situation requires that you have to contact us after hours, please leave a message via phone or E-mail so we can give it immediate attention the following business day.

Service Facility - United States:

Cooper B-Line - USA

509 West Monroe Street
Highland, IL 62249
United States
Phone: (800) 851-7415
Fax: (800) 356-1438
Email: blineus@cooperindustries.com

Service Facility - Canada:

Cooper B-Line - Canada

Div. of Cooper Ind. Canada, Inc.
5925 McLaughlin Road
Mississauga, ON L5R 1B8
Canada
Phone: (800) 569-3660
Fax: (888) 753-3355
Email: blinecanada@cooperindustries.com

Service Facility - Europe:

Cooper B-Line, Ltd. - UK

Walrow, Highbridge
Somerset, TA9 4AQ
United Kingdom
Phone: + 44 (0) 1278 783371
Fax: + 44 (0) 1278 789037
Email: sales@cooperblines.co.uk

Cooper B-Line - Saudia Arabia:

PO Box 70160 - Al Khobar - 31952
Kingdom of Saudia Arabia
Phone: 00966 3 812 2236
Fax: 00966 3 812 1291
Email: blineme@cooperindustries.com

Literature Fulfillment Questions:

Phone: (314) 426-1800
Fax: (314) 426-6022
Email: cooperblines@repcographics.com

Request Literature Website:

<http://order.repcographics.com/cooperb/>

U.S. Customer Service

Cooper B-Line

509 West Monroe Street

Highland, IL 62249

Phone: 800-851-9341

Fax: 770-268-7213