

Series 3 & 4 Stainless Steel

Series 3 & 4 Stainless Steel

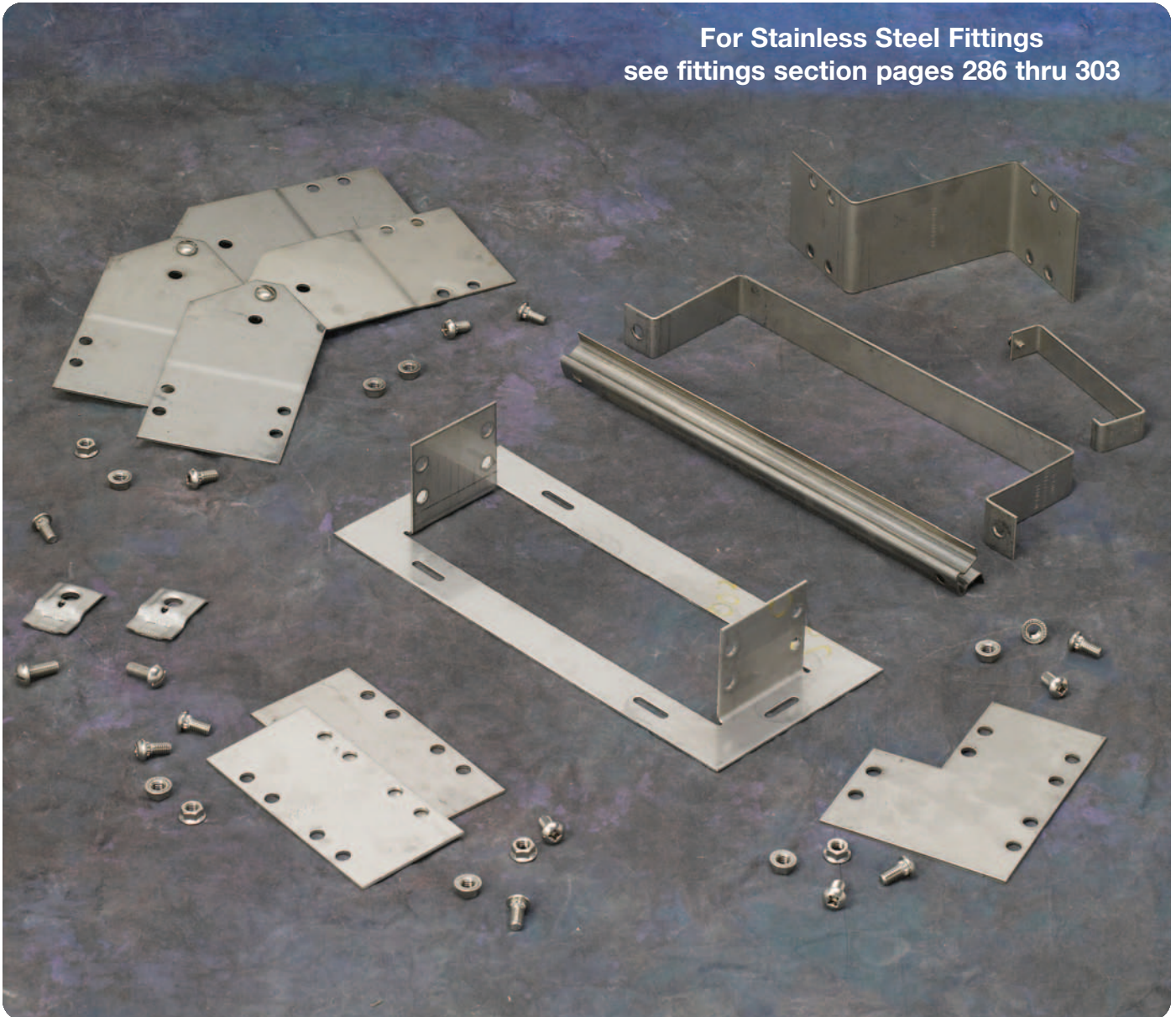

For Stainless Steel Fittings
see fittings section pages 286 thru 303



How The Service Advisor Works

B-Line knows that your time is important! That's why the color-coding system in this catalog is designed to help you select products that fit your service needs. Products are marked to indicate the typical lead time for orders of 50 pieces or less.

Customer: How do I select my straight sections, covers, or fittings so that I get the quickest turnaround?

Service Advisor: Each part of our selection chart is shown in colors. If any section of a part number is a different color, the part will typically ship with the longer lead time represented by the colors.

- Green = Fastest shipped items
- Black = Normal lead-time items
- Red = Normally long lead-time items

Example: 348SS4 09 - 12 - 144
 ● ● ● ●

Part will have a long lead time.

Series 3 & 4 Stainless Steel - Straight Sections

3" NEMA VE 1 Loading Depth 4" Side Rail Height

Straight Section Part Numbering

Prefix
Example: **348 SS6 09 - 24 - 240**

Series	Material	*Type	*Width	Length
● 348	● SS4 = 304 Stainless Steel ● SS6 = 316 Stainless Steel	Ladder- ● 06 = 6" rung spacing ● 09 = 9" rung spacing ● 12 = 12" rung spacing Trough- 6" and Wider ● 04 = Vented Bottom ● SB = Non-Ventilated	● 06 = 6" ● 09 = 9" ● 12 = 12" ● 18 = 18" ● 24 = 24" ● 30 = 30" ● 36 = 36"	● ① 144 = 12 ft. ● ② 120 = 10 ft. 348 ① Primary Length. ② Secondary Length. See page 39 for explanation of lengths. Passivation available see page 18.

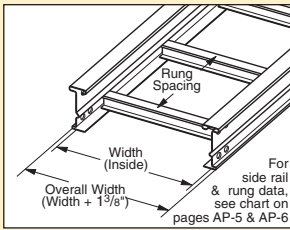

See page 362 for additional rung options. *Special sizes available.

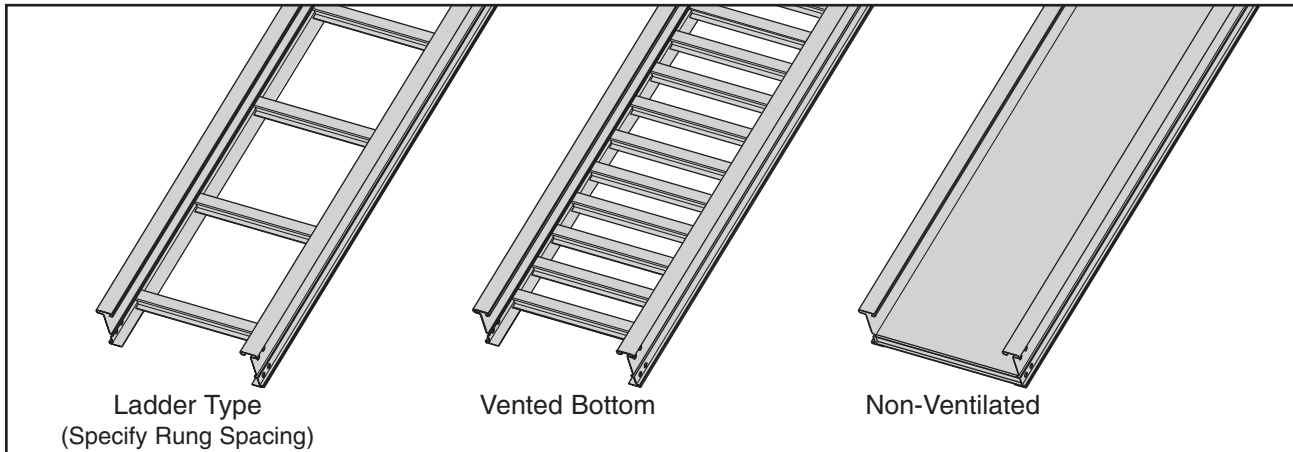

Values are based on simple beam tests per NEMA VE 1 on 36" wide cable tray rungs spaced on 12" centers. Cable trays will support without collapse a 200 lb. (90.7 kg) concentrated load over and above published loads. Published load safety factor is 1.5. To convert 1.5 safety factor to 2.0, multiply published load by 0.75. To obtain mid-span deflection, multiply a load by the deflection multiplier. Cable tray must be supported on spans shorter than or equal to the length of the cable being installed.

B-Line Series	Side Rail Dimensions	NEMA, CSA Classifications	Span ft	Load lbs/ft	Deflection Multiplier	Design Factors for Two Rails	Span meters	Load kg/m	Deflection Multiplier	Design Factors for Two Rails
348 SSt†		NEMA: 16A, 12C CSA: C1-3m UL Cross-Sectional Area: 0.40 in ²	10	180	0.0042	Area=0.74 in ² Sx=0.79 in ³ Ix=1.85 in ⁴	3.0	268	0.072	Area=4.77 cm ² Sx=12.95 cm ³ Ix=77.00 cm ⁴
			12	125	0.009		3.7	186	0.148	
			14	92	0.016		4.3	137	0.275	
			16	70	0.027		4.9	105	0.469	
			18	56	0.044		5.5	83	0.752	
			20	45	0.067		6.1	67	1.145	

When cable trays are used in continuous spans, the deflection of the cable tray is reduced by as much as 50%. Design factors: Ix = Moment of Inertia, Sx = Section Modulus. † Insert 4 for 304 stainless steel or 6 for 316 stainless steel.

● Green = Fastest shipped items ● Black = Normal lead-time items ● Red = Normally long lead-time items

4" NEMA VE 1 Loading Depth 5" Side Rail Height

Straight Section Part Numbering

Prefix
Example: **358 SS6 09 - 24 - 240**

Series	Material	*Type	*Width	Length
● 358	<ul style="list-style-type: none"> ● SS4 = 304 Stainless Steel ● SS6 = 316 Stainless Steel 	Ladder- <ul style="list-style-type: none"> ● 06 = 6" rung spacing ● 09 = 9" rung spacing ● 12 = 12" rung spacing Trough- 6" and Wider <ul style="list-style-type: none"> ● 04 = Vented Bottom ● SB = Non-Ventilated 	<ul style="list-style-type: none"> ● 06 = 6" ● 09 = 9" ● 12 = 12" ● 18 = 18" ● 24 = 24" ● 30 = 30" ● 36 = 36" 	<ul style="list-style-type: none"> ● ① 144 = 12 ft. ● ② 240 = 20 ft. <p style="text-align: right; margin-right: 20px;">358</p> <p>① Primary Length. ② Secondary Length.</p> <p>See page 39 for explanation of lengths.</p> <p>Passivation available see page 18.</p>

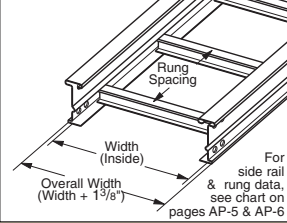

For side rail & rung data, see chart on pages AP-5 & AP-6

See page 362 for additional rung options. *Special sizes available.

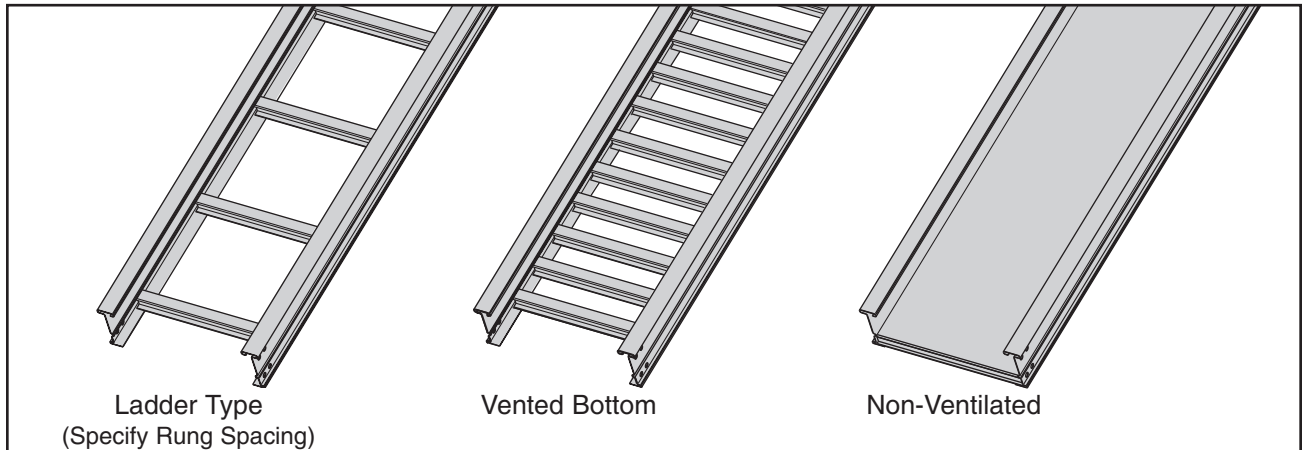

Values are based on simple beam tests per NEMA VE 1 on 36" wide cable tray rungs spaced on 12" centers. Cable trays will support without collapse a 200 lb. (90.7 kg) concentrated load over and above published loads. Published load safety factor is 1.5. To convert 1.5 safety factor to 2.0, multiply published load by 0.75. To obtain mid-span deflection, multiply a load by the deflection multiplier. Cable tray must be supported on spans shorter than or equal to the length of the cable being installed.

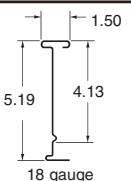
B-Line Series	Side Rail Dimensions	NEMA, CSA & UL Classifications	Span ft	Load lbs/ft	Deflection Multiplier	Design Factors for Two Rails	Span meters	Load kg/m	Deflection Multiplier	Design Factors for Two Rails
358 SS†		NEMA: 20A, 16B CSA: 89 kg/m 6.1m UL Cross-Sectional Area: 0.70 in ²	10	248	0.0025	Area=0.83 in ² Sx=1.09 in ³ Ix=3.10 in ⁴	3.0	369	0.043	Area=5.35 cm ² Sx=17.86 cm ³ Ix=129.03 cm ⁴
			12	172	0.0052		3.7	256	0.089	
			14	127	0.010		4.3	188	0.164	
			16	97	0.016		4.9	144	0.280	
			18	77	0.026		5.5	114	0.448	
			20	62	0.040		6.1	92	0.684	

When cable trays are used in continuous spans, the deflection of the cable tray is reduced by as much as 50%. Design factors: Ix = Moment of Inertia, Sx = Section Modulus. † Insert 4 for 304 stainless steel or 6 for 316 stainless steel.

● Green = Fastest shipped items ● Black = Normal lead-time items ● Red = Normally long lead-time items

Series 3 & 4 Stainless Steel - Straight Sections

5" NEMA VE 1 Loading Depth 6" Side Rail Height

Straight Section Part Numbering

Prefix

Example: **368 SS6 09 - 24 - 240**

Series	Material	*Type	*Width	Length
● 368	● SS4 = 304 Stainless Steel	Ladder- ● 06 = 6" rung spacing ● 09 = 9" rung spacing ● 12 = 12" rung spacing	● 06 = 6" ● 09 = 9" ● 12 = 12" ● 18 = 18" ● 24 = 24" ● 30 = 30" ● 36 = 36"	● ① 240 = 20 ft. 368 ● ② 144 = 12 ft. ● ① 240 = 20 ft. 464 ● ② 288 = 24 ft.

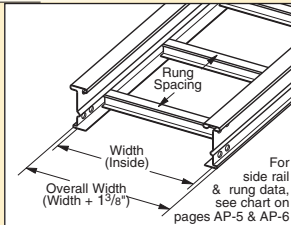

- Trough-
6" and Wider**
- **04** = Vented Bottom
 - **SB** = Non-Ventilated

① Primary Length.
② Secondary Length.
See page 39 for explanation of lengths.
Passivation available see page 18.

See page 362 for additional rung options. *Special sizes available.

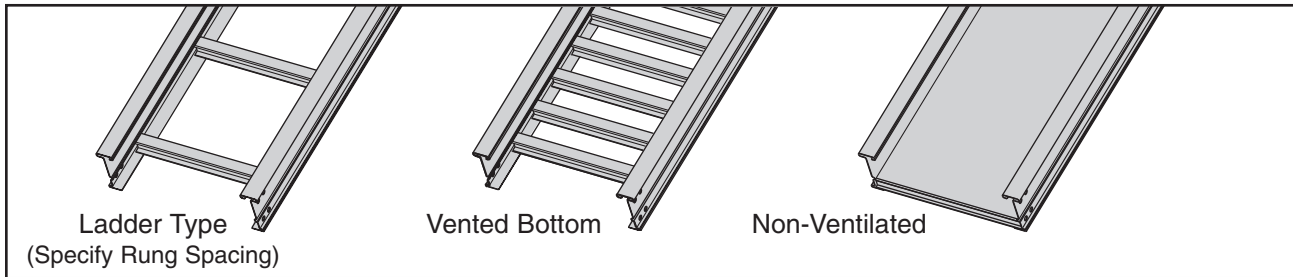

Values are based on simple beam tests per NEMA VE 1 on 36" wide cable tray rungs spaced on 12" centers. Cable trays will support without collapse a 200 lb. (90.7 kg) concentrated load over and above published loads. Published load safety factor is 1.5. To convert 1.5 safety factor to 2.0, multiply published load by 0.75. To obtain mid-span deflection, multiply a load by the deflection multiplier. Cable tray must be supported on spans shorter than or equal to the length of the cable being installed.

B-Line Series	Side Rail Dimensions	NEMA, CSA Classifications	Span ft	Load lbs/ft	Deflection Multiplier	Design Factors for Two Rails	Span meters	Load kg/m	Deflection Multiplier	Design Factors for Two Rails
368 SS†		NEMA: 20A, 16B CSA: D1-3m UL Cross-Sectional Area: 0.70 in ²	10	236	0.0016	Area=0.92 in ² Sx=1.41 in ³ Ix=4.77 in ⁴	3.0	351	0.028	Area=5.94 cm ² Sx=23.11 cm ³ Ix=198.54 cm ⁴
			12	164	0.0034		3.7	244	0.058	
			14	120	0.0062		4.3	179	0.107	
			16	92	0.011		4.9	137	0.182	
			18	73	0.017		5.5	108	0.291	
			20	59	0.026		6.1	88	0.444	

B-Line Series	Side Rail Dimensions	NEMA, CSA Classifications	Span ft	Load lbs/ft	Deflection Multiplier	Design Factors for Two Rails	Span meters	Load kg/m	Deflection Multiplier	Design Factors for Two Rails
464 SS†		NEMA: 20C+ CSA: E-6m UL Cross-Sectional Area: 1.00 in ²	12	342	0.002	Area=1.49 in ² Sx=2.28 in ³ Ix=7.65 in ⁴	3.7	508	0.036	Area=9.61 cm ² Sx=37.36 cm ³ Ix=318.42 cm ⁴
			16	192	0.007		4.9	286	0.113	
			18	152	0.011		5.5	226	0.182	
			20	123	0.016		6.1	183	0.277	
			22	102	0.024		6.7	151	0.406	
			24	85	0.034		7.3	127	0.574	

When cable trays are used in continuous spans, the deflection of the cable tray is reduced by as much as 50%. Design factors:
Ix = Moment of Inertia, Sx = Section Modulus. † Insert 4 for 304 stainless steel or 6 for 316 stainless steel.

● Green = Fastest shipped items ● Black = Normal lead-time items ● Red = Normally long lead-time items

Splice Plates

- Standard 8-hole pattern for all stainless steel splice plates.
- Furnished in pairs with hardware.
- One pair including hardware provided with straight section.
- Boxed in pairs with hardware.
- (*) Insert **SS4** or **SS6**

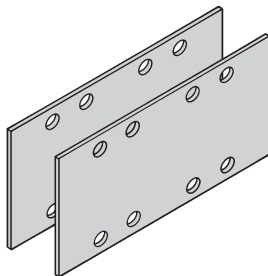

Catalog No.	Height	
	in.	mm
9(*)-8004	4	101
9(*)-8005	5	127
9(*)-8006	6	152

Expansion Splice Plates

- Expansion plates allow for one inch expansion or contraction of the cable tray, or where expansion joints occur in the support structure.
- Furnished in pairs with hardware.
- **Bonding Jumpers are required. Order Separately.**
- (*) Insert **SS4** or **SS6**

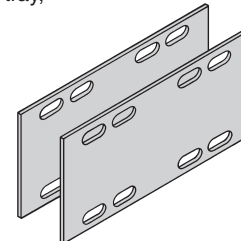

Catalog No.	Height	
	in.	mm
9(*)-8014	4	101
9(*)-8015	5	127
9(*)-8016	6	152

Universal Splice Plates

- Used to splice to existing cable tray systems.
- Furnished in pairs with hardware.
- (*) Insert **SS4** or **SS6**

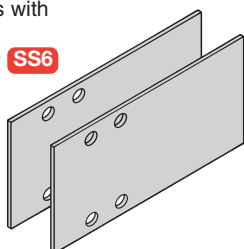

Catalog No.	Height	
	in.	mm
9(*)-8004-1/2	4	101
9(*)-8005-1/2	5	127
9(*)-8006-1/2	6	152

Step Down Splice Plates

- These splice plates are offered for connecting cable tray sections having side rails of different heights.
- Furnished in pairs with hardware.
- (*) Insert **SS4** or **SS6**

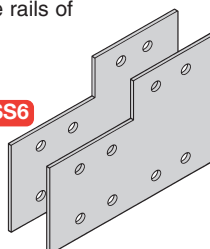

Catalog No.	Height	
	in.	mm
9(*)-8045	5 to 4	127 to 101
9(*)-8046	6 to 4	152 to 101
9(*)-8060	6 to 5	152 to 127

Vertical Adjustable Splice Plates

- These plates provide for changes in elevation that do not conform to standard vertical fittings.
- Furnished in pairs with hardware.
- (*) Insert **SS4** or **SS6**

Requires supports within 24" on both sides, per NEMA VE 2.

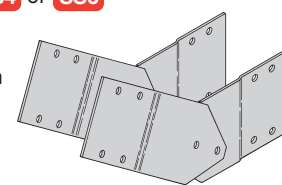

Catalog No.	Height	
	in.	mm
9(*)-8024	4	101
9(*)-8025	5	127
9(*)-8026	6	152

Horizontal Adjustable Splice Plates

- Offered to adjust a cable tray run for changes in direction in a horizontal plane that do not conform to standard horizontal fittings.
- Furnished in pairs with hardware.
- New design bonding jumpers **not** required.
- (*) Insert **SS4** or **SS6**
- (X) Insert 4, 5 or 6 for side rail height.

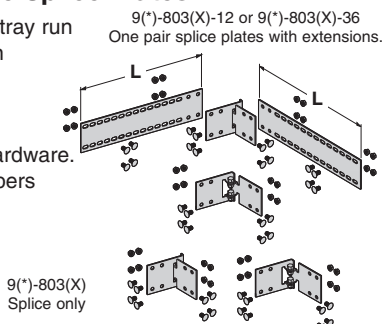

Catalog No.	Cable Tray End Cut	Tray Width	'L'	Requires supports within 24" on both sides, per NEMA VE 2.
9(*)-803(X)	Mitered	Thru 36"	N/A	
9(*)-803(X)-12	Not Mitered	Thru 12"	16"	
9(*)-803(X)-36	Not Mitered	Thru 36"	41"	

Branch Pivot Connectors

- Branch from existing cable tray runs at any point.
- Pivot to any required angle.
- UL Classified for grounding (bonding jumper not required).
- Furnished in pairs with hardware.
- (*) Insert **SS4** or **SS6**

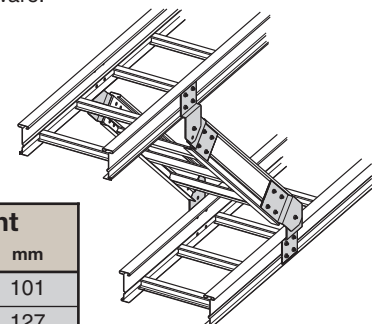

Catalog No.	Height	
	in.	mm
9(*)-8244	4	101
9(*)-8245	5	127
9(*)-8246	6	152

● Green = Fastest shipped items ● Black = Normal lead-time items ● Red = Normally long lead-time items

Series 3 & 4 Stainless Steel - Accessories

Cross Connector Bracket

- For field connecting crossing sections.
- Furnished in pairs with 3/8" hardware.
- (*) Insert **SS4** or **SS6**

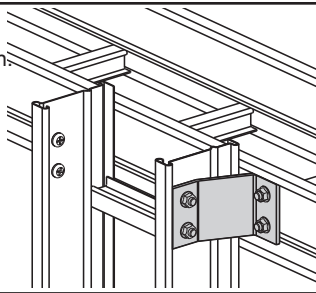
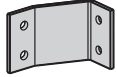

Catalog No. 9(*)-1240

Offset Reducing Splice Plate

- This plate is used for joining cable trays having different widths. When used in pairs they form a straight reduction; when used singly with a standard splice plate, they form an offset reduction.

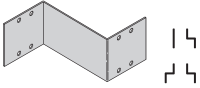

- Furnished as one plate with hardware.
- (‡) Insert reduction
- (*) Insert **SS4** or **SS6**

Catalog No.	Height	
	in.	mm
9(*)-8064-(‡)	4	101
9(*)-8065-(‡)	5	127
9(*)-8066-(‡)	6	152

Tray to Box Splice Plates

- Used to attach the end of a cable tray run to a distribution box or control panel.
- Furnished in pairs with hardware.
- (*) Insert **SS4** or **SS6**

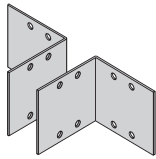

Catalog No.	Height	
	in.	mm
9(*)-8054	4	101
9(*)-8055	5	127
9(*)-8056	6	152

Frame Type Box Connector

- Designed to attach the end of a cable tray run to a distribution cabinet or control center to help reinforce the box at the point of entry.
- Furnished with cable tray connection hardware.
- (‡) Insert tray width
- (*) Insert **SS4** or **SS6**

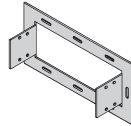

Catalog No.	Height	
	in.	mm
9(*)-8074-(‡)	4	101
9(*)-8075-(‡)	5	127
9(*)-8076-(‡)	6	152

Blind End

- This plate forms a closure for a dead end cable tray.
- Furnished as one plate with hardware.
- (‡) Insert tray width
- (*) Insert **SS4** or **SS6**

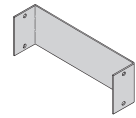

Catalog No.	Height	
	in.	mm
9(*)-8084-(‡)	4	101
9(*)-8085-(‡)	5	127
9(*)-8086-(‡)	6	152

Conduit to Tray Adaptors

- Assembly required.
- Mounting hardware included.
- Conduit clamps provided.
- (‡) = Conduit size (1/2" thru 4").

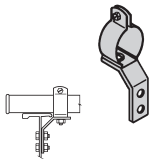

Catalog No. ● 9SS4-1150-(‡)

- Assembly required.
- Conduit clamp included.
- (‡) = Conduit size (1/2" thru 4").

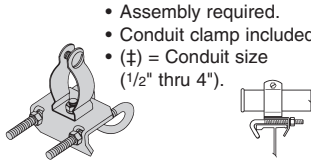

Catalog No. ● 9SS4-1155-(‡)

Conduit to Tray Adaptor

- For easy attachment of conduit terminating at a cable tray.
- Use on aluminum or steel cable trays.

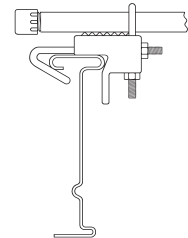
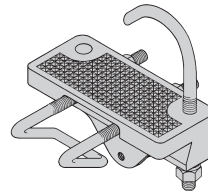

Steel I-Beam

Catalog No.	Conduit Size	
	in.	mm
● 9G-1158-1/2, 3/4	1/2, 3/4	15, 20
● 9G-1158-1, 1 1/4	1, 1 1/4	25, 32
● 9G-1158-1 1/2, 2	1 1/2, 2	40, 50
● 9G-1158-2 1/2, 3	2 1/2, 3	65, 80
● 9G-1158-3 1/2, 4	3 1/2, 4	90, 100

Cable Tie (Ladder Tray)

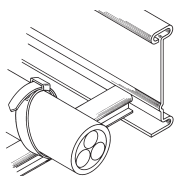

Nylon ties provide easy attachment of cable to ladder rungs; maximum cable O.D. of 3" (76mm).



Overall Length 15"

Catalog No. ● 9-2125-15

● Green = Fastest shipped items ● Black = Normal lead-time items ● Red = Normally long lead-time items

Ladder Drop-Out

- Specially-designed Ladder Drop-Outs provide a rounded surface with 4" (101 mm) radius to protect cable as it exits from the cable tray, preventing damage to insulation. The drop-out will attach to any desired rung.
- (‡) Insert tray width
- (*) Insert **SS4** or **SS6**

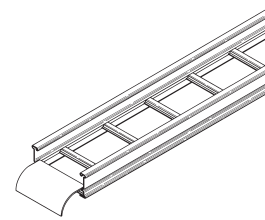
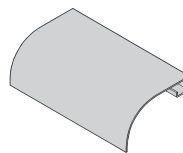

Catalog No. 9(*)-1104-(‡)

Barriers

Straight Section

- Standard length: 120" (3 m) 144" (12 ft.).
- Order catalog number based on loading depth.
- Furnished with four #10 x 1/2" SS4 self-drilling screws and a 99-9982 splice.
- (*) Insert **SS4** or **SS6**

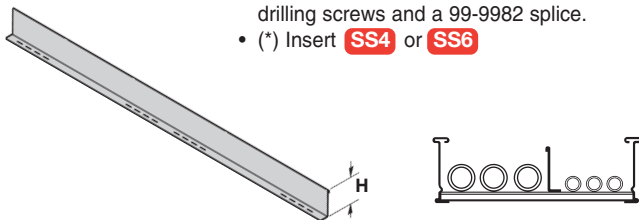

Catalog No.	Side Rail Height		Loading Depth 'H'	
	in.	mm	in.	mm
73(*)-Length	4	101	3	76
74(*)-Length	5	127	4	101
75(*)-Length	6	152	5	127

Length =
144 for 12'
or
120 for 10'

Horizontal Bend

- Horizontal Bend Barriers are flexible in order to conform to any horizontal fitting radius. Cut to length.
- Order catalog number based on loading depth.
- Furnished with three #10 x 1/2" SS4 self-drilling screws and a 99-9982 Barrier Strip Splice.
- Standard length is 72" (6 ft.), sold individually.
- (*) Insert **SS4** or **SS6**

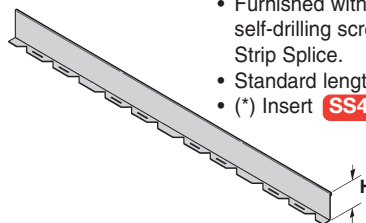

Catalog No.	Side Rail Height		Loading Depth 'H'	
	in.	mm	in.	mm
73(*)-90HBFL	4	101	3	76
74(*)-90HBFL	5	127	4	101
75(*)-90HBFL	6	152	5	127

Vertical Bend Barriers

- Vertical Bend Barriers are preformed to conform to a specific vertical fitting.
- Furnished with three #10 x 1/2" SS4 self-drilling screws and a 99-9982 Barrier Strip Splice.
- (*) Insert **SS4** or **SS6**
- (**) Insert 30, 45, 60 or 90 for degrees
- (†) Insert 12, 24, 36 or 48 for radius

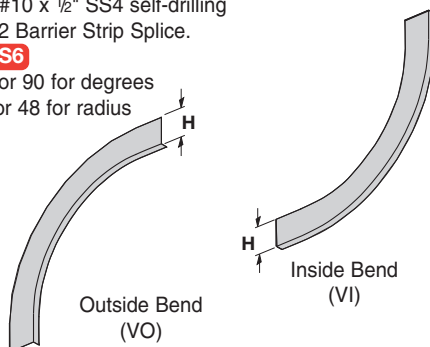

Inside Bend Catalog No.	Outside Bend Catalog No.	Side Rail Height		Loading Depth 'H'	
		in.	mm	in.	mm
73(*)-(**)VI(†)	73(*)-(**)VO(†)	4	101	3	76
74(*)-(**)VI(†)	74(*)-(**)VO(†)	5	127	4	101
75(*)-(**)VI(†)	75(*)-(**)VO(†)	6	152	5	127

Barrier Strip Clip

- Zinc plated steel barrier clip fastens to either aluminum or steel ladder rung.
- Furnished with one #10 x 1/2" SS4 plated self-drilling screw.
- (*) Insert **SS4** or **SS6**

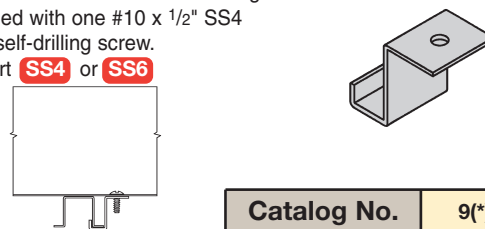

Catalog No. 9(*)-9002

Barrier Strip Splice

- Plastic splice holds adjoining barrier strips in straight alignment.

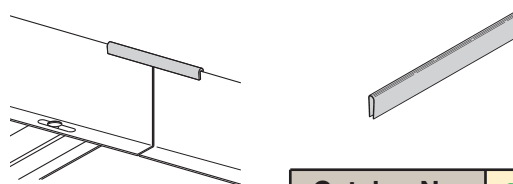

Catalog No. ● 99-9982

● Green = Fastest shipped items ● Black = Normal lead-time items ● Red = Normally long lead-time items

Series 3 & 4 Stainless Steel - Accessories

Series 3 & 4 Stainless Steel

Stainless Steel Cable Clamp

- Fits with series 3 & 4 rungs.
- Shipped flat. Field form around the cable at the time of installation.

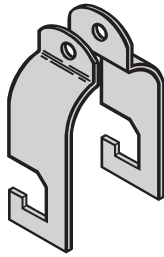

Refer to Section CF
Cable Fixing

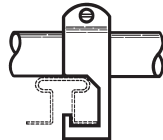
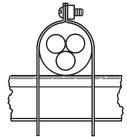

Catalog No.	Cable Size	
	in.	mm
● 9SS4-4050	0.50 - 0.75	13 - 19
● 9SS4-4075	0.75 - 1.00	19 - 25
● 9SS4-4100	1.00 - 1.25	25 - 32
● 9SS4-4125	1.25 - 1.50	32 - 38
● 9SS4-4150	1.50 - 1.75	38 - 45
● 9SS4-4175	1.75 - 2.00	45 - 51
● 9SS4-4200	2.00 - 2.25	51 - 57
● 9SS4-4225	2.25 - 2.50	57 - 64
● 9SS4-4250	2.50 - 2.75	64 - 70
● 9SS4-4275	2.75 - 3.00	70 - 76
● 9SS4-4300	3.00 - 3.25	76 - 82
● 9SS4-4325	3.25 - 3.50	82 - 89
● 9SS4-4350	3.50 - 3.75	89 - 95
● 9SS4-4375	3.75 - 4.00	95 - 102
● 9SS4-4400	4.00 - 4.25	100 - 106
● 9SS4-4425	4.25 - 4.50	106 - 113
● 9SS4-4450	4.50 - 4.75	113 - 121
● 9SS4-4475	4.75 - 5.00	121 - 125

Cable Tray Clamp/Guide

- Features a no-twist design.
- Has four times the strength of the traditional design.
- Each side is labeled to ensure proper installation.
- Available for either 3/8" or 1/2" hardware.
- Furnished in pairs without hardware.

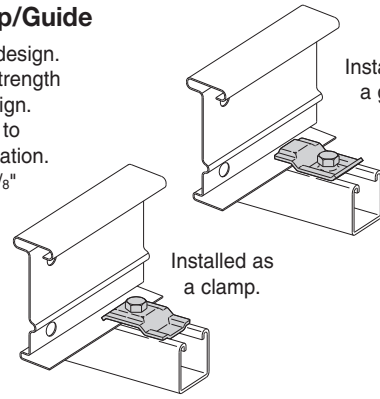

Patent #
RE35479

Catalog No. ● 9SS6-1205

Vertical Tray Hanger

- (*) Insert **SS4** or **SS6**
- Design load 1500 lbs/pair.
Safety Factor of 2.5
- Furnished in pairs with hardware.

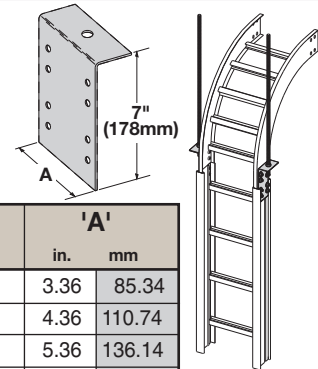

Catalog No.	Outside Cable Tray Ht.	'A'	
		in.	mm
9(*)-8224	4"	3.36	85.34
9(*)-8225	5"	4.36	110.74
9(*)-8226	6"	5.36	136.14
9(*)-8227	7"	6.36	161.54

Cable Tray Guide

- Expansion guide for single or double cable tray runs.
- Guide allows for longitudinal movement of the cable tray.
- No field drilling of support I-beam or channel is required.
- Guides are required on both sides of cable tray to prevent lateral movement - can be placed on either the inside or outside flange of cable tray.
- Guides are sold in pieces - two guides are required per tray.
- Maximum flange thickness 1 1/8" (28.58 mm).

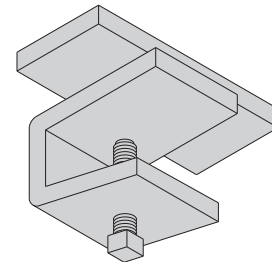
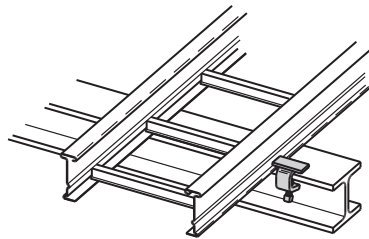

Catalog No.	Finish
● 9G-1249	HDGAF

Threaded Rod (ATR) & Rod Coupling

Size	Loading lbs	Catalog No.	Available Lengths	Coupling Cat. No.
3/8-16	730	● ATR 3/8 x Length	36", 72", 144"	● B655-3/8
1/2-13	1350	● ATR 1/2 x Length	36", 72", 144"	● B655-1/2

Loading based on safety factor 5.

Standard Finish: SS4 or SS6

See B-Line Strut Systems Catalog for other sizes and finishes.

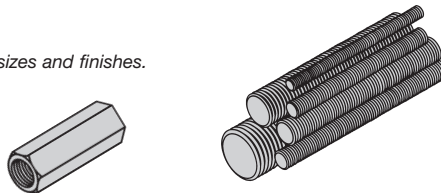

Nylon Pad

- Use for friction reduction.
- Hardness: Shore D80.
- Low friction coefficient.
- UV resistant.
- Excellent weatherability.
- UL - 94HB.

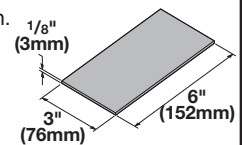

Cat. No. ● 99-NY36

Neoprene Roll

- Use for material isolation.
- 1/8" x 2" x 25' roll.
- Hardness: Shore A60.
- Good weatherability.

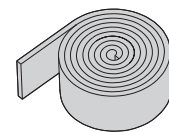

Catalog No. ● 99-NP300

● Green = Fastest shipped items ● Black = Normal lead-time items ● Red = Normally long lead-time items

Cantilever Bracket

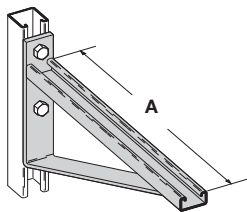

- (*) Insert **SS4** or **SS6**
- Safety Load Factor 2.5

Catalog No.	Uniform Load		Tray Width		'A'	
	lbs	kN	in.	mm	in.	mm
B494-12(*)	1580	7.02	6 & 9	152 & 229	12	305
B494-18(*)	1000	4.45	12	305	18	457
B494-24(*)	996	4.43	18	457	24	610

Cantilever Bracket

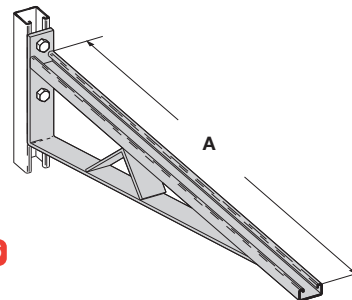

- (*) Insert **SS4** or **SS6**
- Safety Load Factor 2.5

Catalog No.	Uniform Load		Tray Width		'A'	
	lbs	kN	in.	mm	in.	mm
B494-30(*)	924	4.11	24	610	30	762
B494-36(*)	864	3.84	30	762	36	914
B494-42(*)	580	2.58	36	914	42	1067
B494-48(*)	500	2.22	42	1067	48	1219

Cantilever Bracket

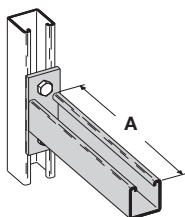

- (*) Insert **SS4** or **SS6**
- Safety Load Factor 2.5

Catalog No.	Uniform Load		Tray Width		'A'	
	lbs	kN	in.	mm	in.	mm
B409-12(*)	960	4.27	6 & 9	152 & 229	12	305
B409-18(*)	640	2.84	12	305	18	457
B409-24(*)	480	2.13	18	457	24	610

Cantilever Bracket

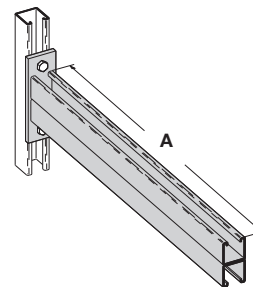

- (*) Insert **SS4** or **SS6**
- Safety Load Factor 2.5

Catalog No.	Uniform Load		Tray Width		'A'	
	lbs	kN	in.	mm	in.	mm
B297-12(*)	1660	7.37	6 & 9	152 & 229	12	305
B297-18(*)	1100	4.88	12	305	18	457
B297-24(*)	835	3.71	18	457	24	610
B297-30(*)	665	2.95	24	610	30	762
B297-36(*)	550	2.44	30	762	36	914
B297-42(*)	465	2.06	36	914	42	1067

Rooftop Support Bases with B22 Channel

Designed as a superior rooftop support for cable tray,

UV resistant and approved for most roofing material or other flat surfaces.

Can be used with any of Cooper B-Line's cable tray clamps and guides.

Ultimate Load Capacity:
1,000 lbs. (uniform load)



Catalog No.	Height x Width x Length
● DB10-28	5 ⁵ / ₈ " x 6" x 28.0"
● DB10-36	5 ⁵ / ₈ " x 6" x 36.0"
● DB10-42	5 ⁵ / ₈ " x 6" x 42.0"
● DB10-50	5 ⁵ / ₈ " x 6" x 50.0"
● DB10-60	5 ⁵ / ₈ " x 6" x 60.0"

LEEDS credit available, base made from 100% recycled material.

General Note: Consult roofing manufacturer or engineer for roof load capacity. The weakest point may be the insulation board beneath the rubber membrane.

● Green = Fastest shipped items ● Black = Normal lead-time items ● Red = Normally long lead-time items

Series 3 & 4 Stainless Steel - Accessories

Beam Clamp

- Sold in pieces with hardware.
- Finishes available: **SS4** or **SS6**

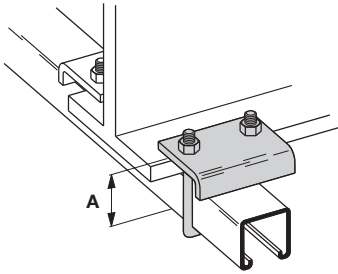

Design load when used in pairs.
Safety Load Factor 5.0

Catalog No.	Design Load*		'A'	
	lbs	kN	in.	mm
B441-22(*)	1200	5.34	3 ³ / ₈	86
B441-22A(*)	1200	5.34	5	127

Beam Clamp B355SS4 ●

- Sold in pieces.
- Design load is 1200 lbs. when used in pairs.
- Safety Load Factor 5.0
- Order HHCS and Channel Nuts separately.

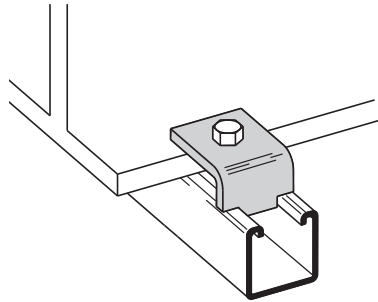

Beam Clamp

- Sold in pieces.
- 304 stainless steel

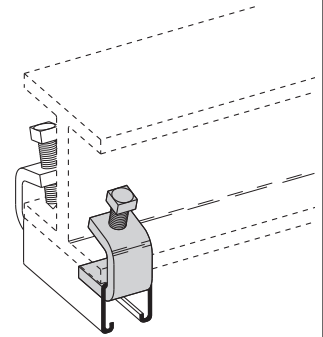

Design load when used in pairs.
Safety Load Factor 5.0

Cat. No.	● B212-1/4SS4		● B212-3/8SS4	
	Design Load *	600 lbs.	2.67 kN	1000 lbs.
Max. Flange Thick	3/4"	19 mm	1 1/8"	28.6 mm
Mat'l. Thickness	1/4"	6.3 mm	3/8"	9.5 mm

Heavy Duty Hold Down Bracket

- Design load is 2000 lbs/pair.
- Two bolt design.
- Sold in pairs.
- 3/8" cable tray attachment hardware provided.
- 1/2" support attachment hardware **not** provided.
- (*) Insert **SS4** or **SS6**

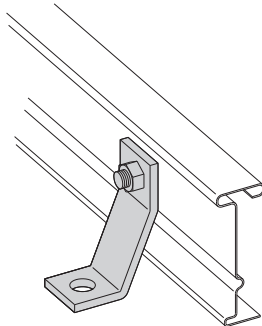

Catalog No. 9(*)-1241

Heavy Duty Hold-Down Bracket

- Design load is 4000 lbs/pair.
- Four bolt design.
- Sold in pairs.
- 3/8" cable tray attachment hardware provided
- 1/2" support attachment hardware **not** provided.
- (*) Insert **SS4** or **SS6**

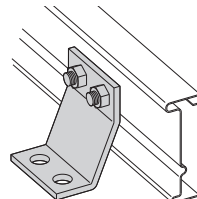

Catalog No. 9(*)-1242

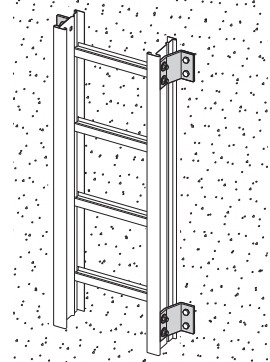

● Green = Fastest shipped items ● Black = Normal lead-time items ● Red = Normally long lead-time items

Covers

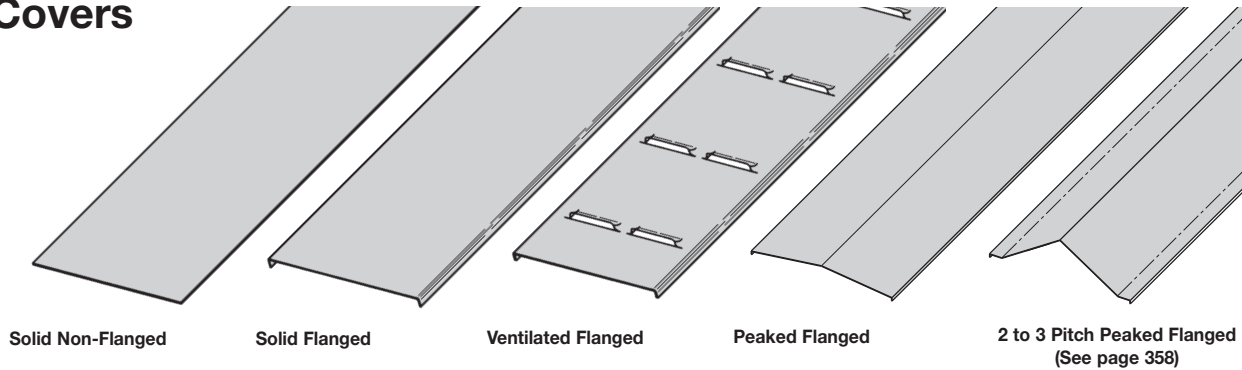

A full range of covers is available for straight sections and fittings.

Solid covers should be used when maximum enclosure of the cable is desired and no accumulation of heat is expected. **Ventilated covers** provide an overhead cable shield yet allow heat to escape.

Cooper B-Line recommends that covers be placed on vertical cable tray runs to a height of 6 ft. (1.83 m) to 8 ft. (2.44 m) above the floor to isolate both cables and personnel. **Flanged covers** have a 1/2 in. (13 mm) flange. Cover clamps are **not included** with the cover and must be ordered separately. All **peaked covers** are flanged. Standard peaked covers have 1/2" peak. Special purpose peaked covers, having a 2 to 3 pitch, provide additional slope and material thickness. The 2 to 3 pitch fitting covers are of multiple piece, welded construction.

Stainless Steel Cover Part Numbering

Prefix
Example: **80 3 SS4 - 20 - 24 - 144**

Cover Type	Detail	Material	Material Thickness	Tray Width	Item Description
<ul style="list-style-type: none"> ● 80 = Solid ● 81 = Ventilated ● 82 = Peaked 	<ul style="list-style-type: none"> ● 2= Flanged Stainless Steel (All fittings) ● 3= Flanged Stainless Steel (All straight sections) ● 4= Non-Flanged Stainless Steel (80 & 81 type only) (All fittings) 	<ul style="list-style-type: none"> ● SS4 = 304 Stainless Steel ● SS6 = 316 Stainless Steel 	<ul style="list-style-type: none"> ● 20 = 20 Ga. Stainless Steel 	<ul style="list-style-type: none"> ● 06 = 6" ● 09 = 9" ● 12 = 12" ● 18 = 18" ● 24 = 24" ● 30 = 30" ● 36 = 36" 	<p>For Straight Section Cover:</p> <ul style="list-style-type: none"> ● 144 = 12 ft. (3.66 m) ● 120 = 10 ft. (3.05 m) ● 72 = 6 ft. (1.83 m) ● 60 = 5 ft. (1.52 m) <p>For fitting covers: Insert suffix of fitting to be covered. See example below.</p>

Covers 30" and 36" wide have reinforcing ridges.

Examples of Catalog Numbers for Fitting Covers:

Horizontal Bend Cover		Vertical Bend Cover	
Prefix	Suffix	Prefix	Suffix
80 2	SS4 20 - 18 - 90 HB 24	80 2	SS4 20 - 24 - 90 VO 24 - 4*
	Radius		Side Rail*
	Fitting		Height
	Angle		Radius
	Width		Fitting
	Material		Angle
	Thickness		Width
	Material		Material
	Detail		Thickness
	Cover Type		Material
			Detail
			Cover Type

* Required for VO fittings only

● Green = Fastest shipped items ● Black = Normal lead-time items ● Red = Normally long lead-time items

Series 3 & 4 Stainless Steel - Accessories

Series 3 & 4 Stainless Steel

Standard Cover Clamp

- For indoor service only.
- Sold per piece.

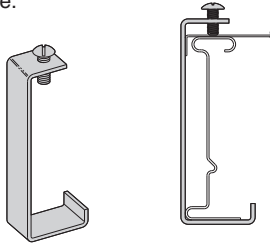

Tray Type	Side Rail Height		Catalog No.
	in.	mm	
Stainless Steel	4	101	● 9SS6-9014
	5	127	● 9SS6-9015
	6	152	● 9SS6-9016

Combination Cover and Hold Down Clamp

- Sold per piece.
- (*) Insert **SS4** or **SS6**
- For indoor service only.

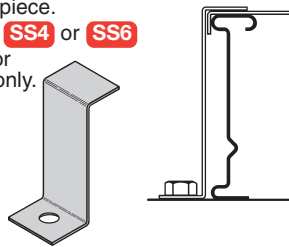

Tray Type	Side Rail Height		Catalog No.
	in.	mm	
Stainless Steel	4	101	9(*)-9043
	5	127	9(*)-9053
	6	152	9(*)-9063

Raised Cover Clamp

- For indoor service only.
- (*) Insert **SS4** or **SS6**
- For use with flanged covers only.

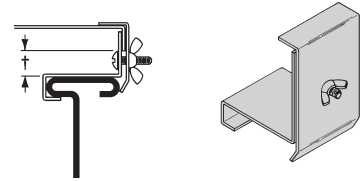

† Specify gap of 1", 2", 3" or 4".

Tray Type	Catalog No.
Series 3 & 4 Steel Straight Section	9(*)-9115-†
All Steel Fittings	9(*)-910†

Heavy Duty Cover Clamp

- Recommended for outdoor service.
- (*) Insert **SS4** or **SS6**

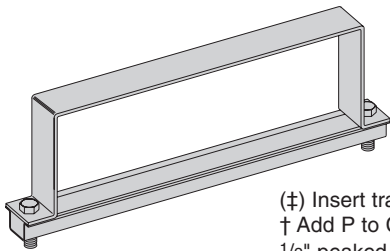

Peaked Cover Clamp

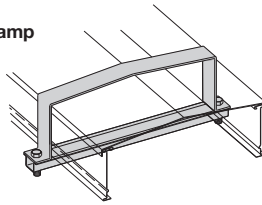

(‡) Insert tray width
† Add P to Catalog No. for 1/2" peaked cover clamp.

Catalog No.	Side Rail Height	
	in.	mm
9(*)-(‡)-9044†	4	101
9(*)-(‡)-9054†	5	127
9(*)-(‡)-9064†	6	152

Cover Joint Strip

- Used to join Covers
- Plastic
- (‡) Insert tray width

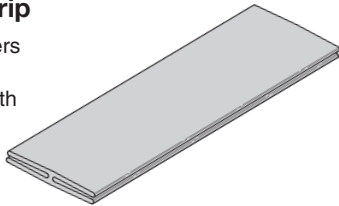

Catalog No. ● 99-9980-(‡)

Quantity of Standard Cover Clamps Required

- Straight Section 60" or 72"4 pcs.
- Straight Section 120" or 144"6 pcs.
- Horizontal/Vertical Bends4 pcs.
- Tees6 pcs.
- Crosses8 pcs.

Note: When using the Heavy Duty Cover Clamp, only one-half the number of clamps stated above is required.

Cable Cleats

(see pages 356 thru 360)

Trefoil Cable Cleats



Single Cable Cleats

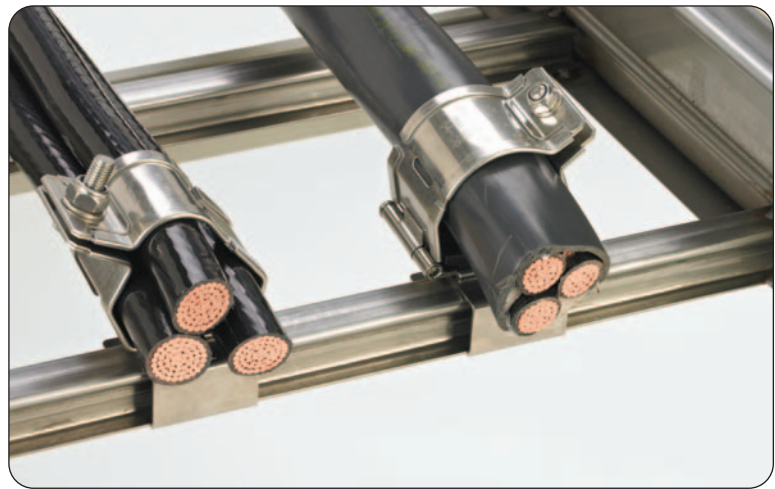
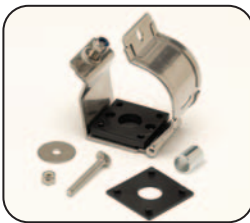

● Green = Fastest shipped items ● Black = Normal lead-time items ● Red = Normally long lead-time items

Section 1- Acceptable Manufacturers

- 1.01 Manufacturer: Subject to compliance with these specifications, cable tray systems shall be as manufactured by Cooper B-Line, Inc.

Section 2- Cable Tray Sections and Components

- 2.01 General: Except as otherwise indicated, provide metal cable trays, of types, classes and sizes indicated; with splice plates, bolts, nuts and washers for connecting units. Construct units with rounded edges and smooth surfaces; in compliance with applicable standards; and with the following additional construction features. Cable tray shall be installed according to the latest revision of NEMA VE 2.
- 2.02 Stainless Steel: Straight section and fitting side rails and rungs shall be made of AISI Type [304] [316] stainless steel. Transverse members (rungs) or corrugated bottoms shall be welded to the side rails with Type 316 stainless steel welding wire. Hardware shall be AISI Type 316 stainless steel.
- 2.03 Ladder Cable Trays shall consist of two longitudinal members (side rails) with transverse members (rungs) welded to the side rails. Rungs shall be spaced [6] [9] [12] inches on center. Rung spacing in radiused fittings shall be industry standard 9" and measured at the center of the tray's width. Each rung must be capable of supporting a 200 lb. concentrated load at the center of the cable tray with a safety factor of 1.5.
- 2.04 Ventilated Trough Cable Trays shall consist of two longitudinal members (side rails) with a corrugated bottom welded to the side rails or rungs spaced 4" on center. The peaks of the corrugated bottom shall have a minimum flat cable bearing surface of 2³/₄" and shall be spaced on 6" centers. To provide ventilation in the tray, the valleys of the corrugated bottom shall have 2¹/₄" x 4" rectangular holes punched along the width of the bottom.
- 2.05 Non-Ventilated Bottom Trough Cable Trays shall consist of two longitudinal members (side rails) with a corrugated bottom welded to the side rails or a solid sheet over rungs. The peaks of the corrugated bottom shall have a minimum flat cable bearing surface of 2³/₄" and shall be spaced on 6" centers.
- 2.06 Cable tray loading depth shall be [3] [4] [5] inches per NEMA VE 1.
- 2.07 Straight sections shall be fabricated as I-beams. Straight sections shall be supplied in standard [12 foot] [24 foot] [10 foot (3 m)] [20 foot (6 m)] lengths.
- 2.08 Cable tray widths shall be [6] [9] [12] [18] [24] [30] [36] inches or as shown on drawings.
- 2.09 Splice plates shall be manufactured of high strength steel and be secured with 8 nuts and bolts per plate. The resistance of fixed splice connections between an adjacent section of tray shall not exceed 0.00033 ohm.
- 2.11 All fittings must have a minimum radius of [12] [24] [36] [48] inches.

Section 3- Loading Capacities and Testing

- 3.01 Cable tray shall be capable of carrying a uniformly distributed load of _____ lbs./ft. on a _____ ft. support span with a safety factor of 1.5 when supported as a simple span and tested per NEMA VE 1 5.2. In addition to the uniformly distributed load the cable tray shall support 200 lbs. concentrated load at mid-point of span. Load and safety factors specified are applicable to both the side rails and rung capacities. Cable tray shall be made to manufacturing tolerances as specified by NEMA.
- 3.02 Upon request, manufacturer shall provide test reports in accordance with the latest revision of NEMA VE 1 or CSA C22.2 No. 126.