

Horizontal Expanding Tee (HT)

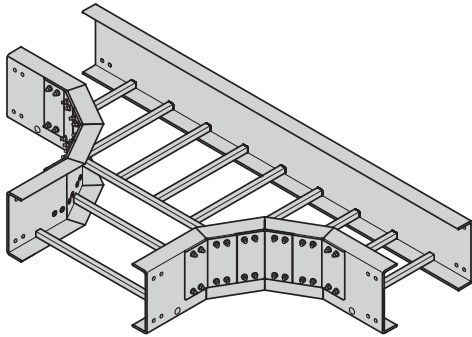

Two pair of splice plates with SS6 hardware included.

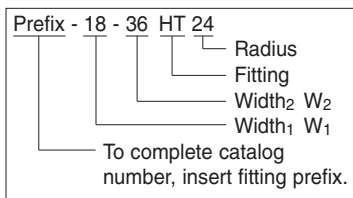

(Prefix) See page 330 for catalog number prefix.
Dimensions for reference only, when critical contact factory.

For 3" Fittings

(Radius 12" only)

W₁ tray widths - 6" thru 18"

W₂ tray widths - 9" thru 24"

Polyester, Vinyl Ester, Zero Halogen/Dis-Stat

All are mitered

For 4" Fittings

(Radius 12", 24" & 36")

W₁ tray widths - 6" thru 30"

W₂ tray widths - 9" thru 36"

Polyester, Vinyl Ester, Zero Halogen/Dis-Stat

All radius are mitered

For 6" Fittings

(Radius 12", 24" & 36")

W₁ tray widths - 6" thru 30"

W₂ tray widths - 9" thru 36"

Polyester, Vinyl Ester, Zero Halogen/Dis-Stat

All radius are mitered

For 8" Fittings

(Radius 12", 24" & 36")

W₁ tray widths - 6" thru 30"

W₂ tray widths - 9" thru 36"

Polyester, Vinyl Ester, Zero Halogen/Dis-Stat

All radius are mitered

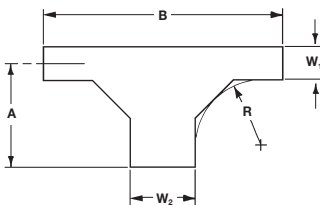

Mitered

(For dimensions, see chart on page 339)

Horizontal Expanding Tee (HT)

Mitered Fittings

| Tray Width | | | | Catalog No. * Insert radius (12", 24" or 36") | 12" Radius (305) | | | | 24" Radius (609) | | | | 36" Radius (914) | | | |
|----------------|-----|----------------|-----|---|------------------|-----|-----|------|------------------|------|-----|------|------------------|------|------|------|
| W ₁ | | W ₂ | | | A | | B | | A | | B | | A | | B | |
| in. | mm | in. | mm | | in. | mm | in. | mm | in. | mm | in. | mm | in. | mm | in. | mm |
| 6 | 152 | 9 | 228 | (Prefix)-06-09-HT* | 19¼ | 489 | 41½ | 1054 | 31¼ | 794 | 65½ | 1664 | 43¼ | 1098 | 89½ | 2273 |
| | | 12 | 305 | (Prefix)-06-12-HT* | 19¼ | 489 | 44½ | 1130 | 31¼ | 794 | 68½ | 1740 | 43¼ | 1098 | 92½ | 2349 |
| | | 18 | 457 | (Prefix)-06-18-HT* | 19¼ | 489 | 50½ | 1283 | 31¼ | 794 | 74½ | 1892 | 43¼ | 1098 | 98½ | 2502 |
| | | 24 | 609 | (Prefix)-06-24-HT* | 19¼ | 489 | 56½ | 1435 | 31¼ | 794 | 80½ | 2045 | 43¼ | 1098 | 104½ | 2654 |
| | | 30 | 762 | (Prefix)-06-30-HT* | 19¼ | 489 | 62½ | 1587 | 31¼ | 794 | 86½ | 2197 | 43¼ | 1098 | 110½ | 2807 |
| | | 36 | 914 | (Prefix)-06-36-HT* | 19¼ | 489 | 68½ | 1740 | 31¼ | 794 | 92½ | 2349 | 43¼ | 1098 | 116½ | 2959 |
| 9 | 228 | 12 | 305 | (Prefix)-09-12-HT* | 20¾ | 527 | 44½ | 1130 | 32¾ | 832 | 68½ | 1740 | 44¾ | 136 | 92½ | 2349 |
| | | 18 | 457 | (Prefix)-09-18-HT* | 20¾ | 527 | 50½ | 1283 | 32¾ | 832 | 74½ | 1892 | 44¾ | 136 | 98½ | 2502 |
| | | 24 | 609 | (Prefix)-09-24-HT* | 20¾ | 527 | 56½ | 1435 | 32¾ | 832 | 80½ | 2045 | 44¾ | 136 | 104½ | 2654 |
| | | 30 | 762 | (Prefix)-09-30-HT* | 20¾ | 527 | 62½ | 1587 | 32¾ | 832 | 86½ | 2197 | 44¾ | 136 | 110½ | 2807 |
| | | 36 | 914 | (Prefix)-09-36-HT* | 20¾ | 527 | 68½ | 1740 | 32¾ | 832 | 92½ | 2349 | 44¾ | 136 | 116½ | 2959 |
| 12 | 305 | 18 | 457 | (Prefix)-12-18-HT* | 22¼ | 565 | 50½ | 1283 | 34¼ | 870 | 74½ | 1892 | 46¼ | 1175 | 98½ | 2502 |
| | | 24 | 609 | (Prefix)-12-24-HT* | 22¼ | 565 | 56½ | 1435 | 34¼ | 870 | 80½ | 2045 | 46¼ | 1175 | 104½ | 2654 |
| | | 30 | 762 | (Prefix)-12-30-HT* | 22¼ | 565 | 62½ | 1587 | 34¼ | 870 | 86½ | 2197 | 46¼ | 1175 | 110½ | 2807 |
| | | 36 | 914 | (Prefix)-12-36-HT* | 22¼ | 565 | 68½ | 1740 | 34¼ | 870 | 92½ | 2349 | 46¼ | 1175 | 116½ | 2959 |
| 18 | 457 | 24 | 609 | (Prefix)-18-24-HT* | 25¼ | 641 | 56½ | 1435 | 37¼ | 946 | 80½ | 2045 | 49¼ | 1251 | 104½ | 2654 |
| | | 30 | 762 | (Prefix)-18-30-HT* | 25¼ | 641 | 62½ | 1587 | 37¼ | 946 | 86½ | 2197 | 49¼ | 1251 | 110½ | 2807 |
| | | 36 | 914 | (Prefix)-18-36-HT* | 25¼ | 641 | 68½ | 1740 | 37¼ | 946 | 92½ | 2349 | 49¼ | 1251 | 122½ | 3111 |
| 24 | 609 | 30 | 762 | (Prefix)-24-30-HT* | 28¼ | 717 | 62½ | 1587 | 40¼ | 1022 | 86½ | 2197 | 52¼ | 1327 | 110½ | 2807 |
| | | 36 | 914 | (Prefix)-24-36-HT* | 28¼ | 717 | 68½ | 1740 | 40¼ | 1022 | 92½ | 2349 | 52¼ | 1327 | 116½ | 2959 |
| 30 | 762 | 36 | 914 | (Prefix)-30-36-HT* | 31¼ | 794 | 68½ | 1740 | 43¼ | 1098 | 92½ | 2349 | 55¼ | 1403 | 116½ | 2959 |