

Channel Cable Tray - Straight Sections

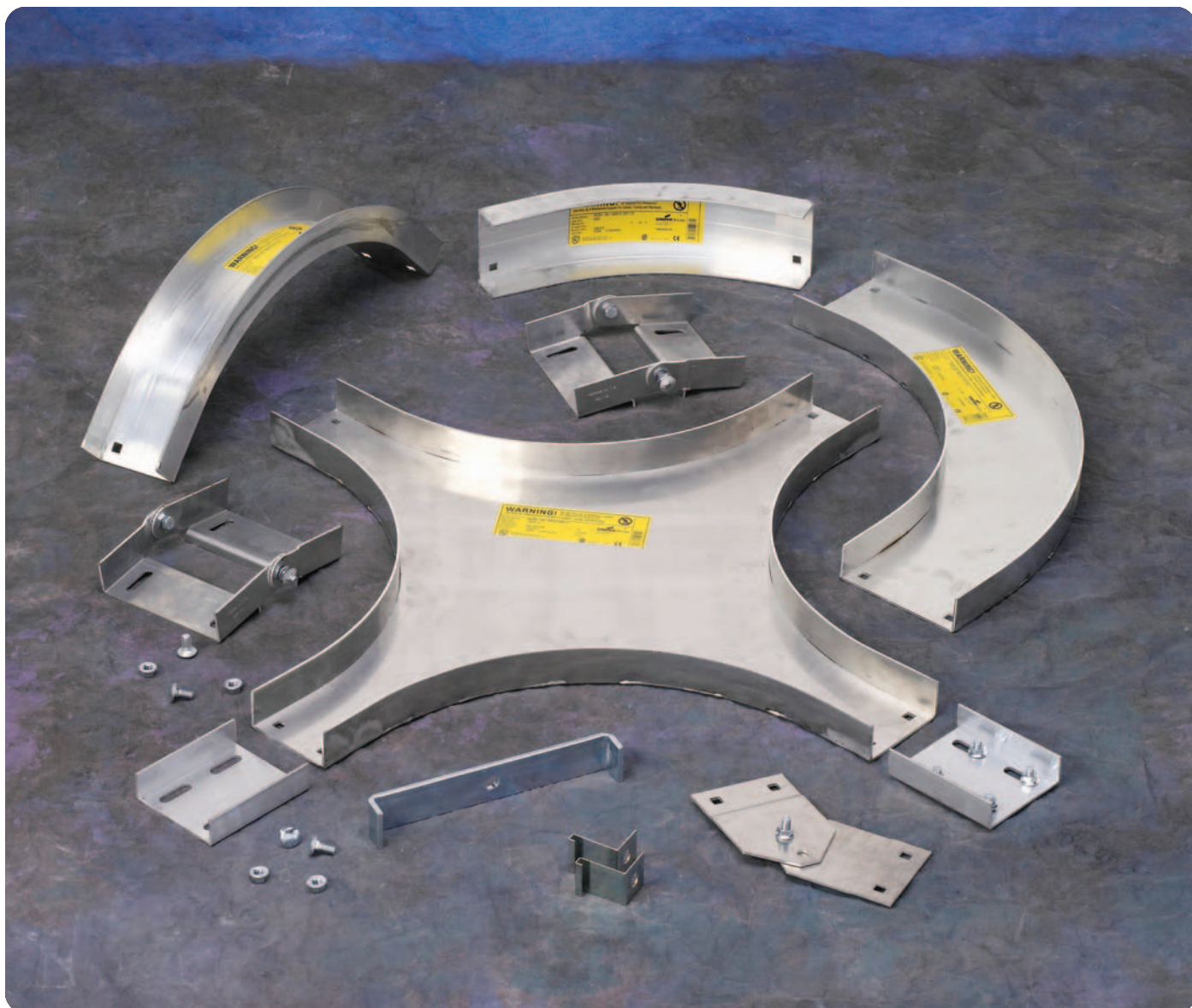



How The Service Advisor Works

B-Line knows that your time is important! That's why the color-coding system in this catalog is designed to help you select products that fit your service needs. Products are marked to indicate the typical lead time for orders of 50 pieces or less.

Customer: How do I select my cable channel product so that I get the quickest turnaround?

Service Advisor: Each part of our selection chart is shown in colors. If any section of a part number is a different color, the part will typically ship with the longer lead time represented by the colors.

- Green = Fastest shipped items
- Black = Normal lead-time items
- Red = Normally long lead-time items

Example:

A **CC** **03** - **144**
● ● ● ●

Part will have a normal lead time because of the 03 width.

Changing the part number to 04 width instead of 03 will reduce the lead time.

Channel Cable Tray - Straight Sections

Straight Section Part Numbering

Prefix
Example: **A CC - 04 - 120**

Material

- **A** = Aluminum 6063-T4
- **G** = Type 1 - HDGAF
- **P** = Type 2 - Pre-Galvanized
- **SS4** = 304 Stainless Steel
- **SS6** = 316 Stainless Steel

Type

- **CC** = Ventilated Cable Channel
- **CCN** = Non-Ventilated Cable Channel

Width

- **03** = 3"
- **04** = 4"
- **06** = 6"

Length

- **① 144** = 12 ft.
- **② 120** = 10 ft.

① Primary Length.
② Secondary Length.

See page 39 for explanation of lengths.

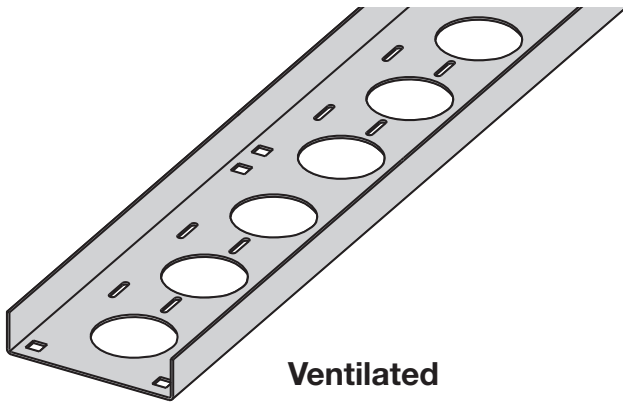

Ventilated

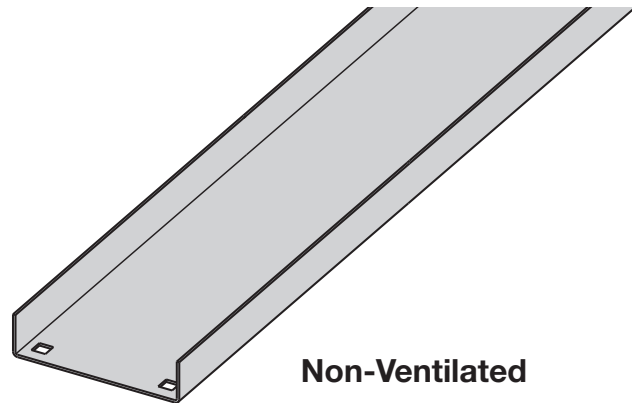

Non-Ventilated

Ventilated straight sections contain 2¹/₄" diameter holes and 3³/₁₆" x 7⁷/₈" slots for cable attachment. Ventilated straight sections also have splice holes repeating every 12" to simplify field modifications.

Material Type	Width in.	Depth in.	UL Area in. ²	Load Data * Safety Factor = 1.5	Support Span (Ft)				Load Data * Safety Factor = 1.5	Support Span (m)			
					5	6	10	12		1.5	1.8	3.0	3.7
Aluminum	3 (75)	1.25 (32)	0.6	Load (lbs/ft)	22	15	5	4	Load (kg/m)	33	22	7	6
				Deflection Multiplier	0.025	0.051	0.395	0.820	Deflection Multiplier	.427	0.871	6.743	13.997
	4 (100)	1.75 (44)	0.6	Load (lbs/ft)	48	33	12	8	Load (kg/m)	71	49	18	12
				Deflection Multiplier	0.0071	0.015	0.114	0.236	Deflection Multiplier	0.121	0.256	1.946	4.028
	6 (150)	1.75 (44)	1.00	Load (lbs/ft)	52	36	13	9	Load (kg/m)	77	54	19	13
				Deflection Multiplier	0.0055	0.011	0.088	0.183	Deflection Multiplier	0.094	0.188	1.502	3.124
Steel 14 Gauge	3 (75)	1.25 (32)	0.20	Load (lbs/ft)	24	17	6	4	Load (kg/m)	36	25	9	6
				Deflection Multiplier	0.013	0.028	0.216	0.447	Deflection Multiplier	0.222	0.478	3.687	7.630
	4 (100)	1.75 (44)	0.40	Load (lbs/ft)	52	36	13	9	Load (kg/m)	77	54	19	13
				Deflection Multiplier	0.0039	0.0082	0.063	0.130	Deflection Multiplier	0.067	0.140	1.075	2.219
	6 (150)	1.75 (44)	0.40	Load (lbs/ft)	59	41	15	10	Load (kg/m)	88	61	22	15
				Deflection Multiplier	0.003	0.0063	0.049	0.101	Deflection Multiplier	0.051	0.108	0.836	1.724

To calculate simple Beam Deflection in inches, multiply the design load (lbs/ft) by the Deflection Multiplier shown for the span.
To calculate simple Beam Deflection in millimeters, multiply the design load (kg/m) by the Deflection Multiplier shown for the span.
All dimensions in parentheses are millimeters unless otherwise specified.

* Load data is determined by realistic deflection, not by failure.

● Green = Fastest shipped items ● Black = Normal lead-time items ● Red = Normally long lead-time items

Channel Cable Tray - Accessories

Splice Plate

The Splice Plate has the standard 4-hole pattern for all cable channel.

- Provided with straight sections and fittings.
- Furnished as one plate with hardware.
- (*) Insert **A G P SS4 SS6**

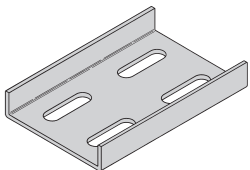

Catalog No.	Channel Width	
	in.	mm
9(*)-1043	3	76
9(*)-1044	4	101
9(*)-1044-6	6	152

Blind End Plate

The Blind End Plate forms a closure for any cable channel dead end.

- Furnished as one plate with hardware.
- (*) Insert **A G P SS4 SS6**

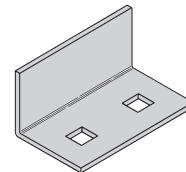

Catalog No.	Channel Width	
	in.	mm
9(*)-1583	3	76
9(*)-1584	4	101
9(*)-1586	6	152

Horizontal Adjustable Splice Plate

The Horizontal Adjustable Splice Plate adapts to changes in direction in a horizontal plane, beyond the capability of the standard horizontal fittings.

- Furnished as one plate with hardware.
- (*) Insert **A G P SS4 SS6**

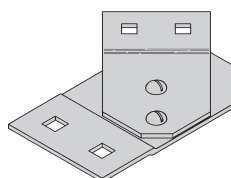

Requires supports within 24" on both sides, per NEMA VE 2.

Catalog No.	Channel Width	
	in.	mm
9(*)-1743	3	76
9(*)-1744	4	101
9(*)-1746	6	152

Vertical Adjustable Splice Plate

The Adjustable Splice Plate allows changes in elevation where standard vertical fittings are not applicable.

- Furnished as one plate with hardware.
- (*) Insert **A G P SS4 SS6**

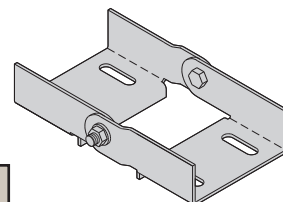

Requires supports within 24" on both sides, per NEMA VE 2.

Catalog No.	Channel Width	
	in.	mm
9(*)-1643	3	76
9(*)-1644	4	101
9(*)-1646	6	152

Box Connector

The Box Connector is used to attach the end of a cable channel run to a distribution box or a control center.

- Furnished as one connector with hardware.
- (*) Insert **A G P SS4 SS6**

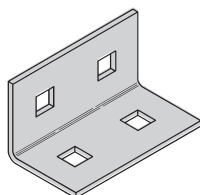

Catalog No.	Channel Width	
	in.	mm
9(*)-1543	3	76
9(*)-1544	4	101
9(*)-1546	6	152

Channel To Tray or Channel To Channel Connector

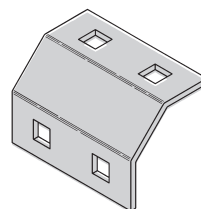

Channel to Channel

Channel to Tray



Catalog No.	Channel Width	
	in.	mm
9(*)-1261-3	3	76
9(*)-1261-4	4	101
9(*)-1261-6	6	152

The Channel Connector is used to link a cable channel to a cable tray, or a cable channel to cable channel.

- Furnished as one plate with hardware.
- (*) Insert **A G P SS4 SS6**

Channel Reducer Plate

The Channel Reducer Plate is used to join cable channel sections of different widths.

- Furnished as one plate with hardware.
- (*) Insert **A G P SS4 SS6**

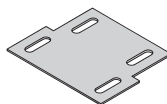

Catalog No.	Channel Width	
	in.	mm
9(*)-1843	4 to 3	101 to 76
9(*)-1863	6 to 3	152 to 76
9(*)-1864	6 to 4	152 to 101

Mounting Bracket - Channel To Tray

The Mounting Bracket allows a parallel run of cable channel to be attached to the side of a cable tray. It can also serve as a support splice connection.

- Furnished as one bracket.
- Order hardware separately.
- (*) Insert **A G ZN SS4 SS6**

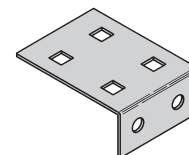

Catalog No.	Channel Width	
	in.	mm
9(*)-1237-3	3	76
9(*)-1237-4	4	101
9(*)-1237-6	6	152



All dimensions in shaded areas are millimeters unless otherwise specified.

● Green = Fastest shipped items ● Black = Normal lead-time items ● Red = Normally long lead-time items

Channel Cable Tray - Accessories

Expansion Guide Clamp

The Expansion Guide Clamp allows cable channel to expand and contract in the horizontal plane, but not in the transverse plane.

- Furnished as one clamp.
- Order 1/2" hardware separately.
- (*) Insert **A G ZN SS4 SS6**

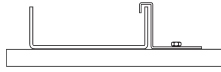

Catalog No.	Channel Width	
	in.	mm
9(*)-1243	3	76
9(*)-1244	4	101
9(*)-1244	6	152

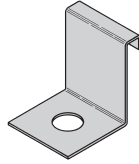

Hold-Down Clamp

The Hold-Down Clamp secures cable channel to a support member.

- Furnished as one clamp.
- Order 1/2" hardware separately.
- (*) Insert **A G ZN SS4 SS6**



Catalog No.	Channel Width	
	in.	mm
9(*)-1245	3	76
9(*)-1246	4	101
9(*)-1246	6	152

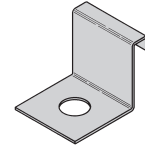

Channel To Floor Base Plate

The Channel to Floor Base Plate is used to attach the end of a cable channel run to the floor or to an equipment mounting pad.

- Anchors and hardware are ordered separately.
- (*) Insert **A G ZN SS4 SS6**

Catalog No.	Channel Width	
	in.	mm
9(*)-3305-3	3	76
9(*)-3305-4	4	101
9(*)-3305-6	6	152

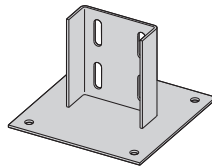

Cable Channel Bushing

The Cable Channel Bushing is a snap-in plastic bushing used to protect cable insulation from mechanical wear.

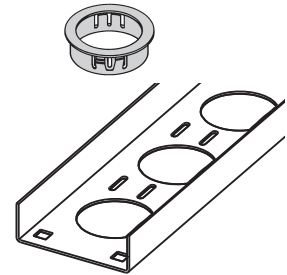

Catalog No.	99-1125
-------------	---------

Cable Channel Bracket

- Uniform Load: 225 lbs (1.00 kN)
Safety Factor of 2.5
- Finishes available: **ZN G**

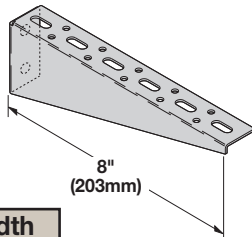

Catalog No.	Channel Width	
	in.	mm
B185CCL	3	76
	4	101
	6	152

Cable Channel Bracket

- Safety Factor of 2.5
- Finishes available: **ZN G GRN**

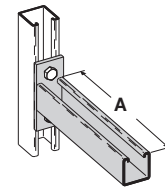

Catalog No.	Channel Width		Uniform Load		A	
	in.	mm	lbs	kN	in.	mm
B409-6	3	76	1920	8.54	6	152
B409-9	4, 6	101, 152	1280	5.69	9	228

Cable Channel Hanger

Designed for 1/2" Threaded Rod, Double Nut Installation

Single Cable Channel Hanger and Wall Mount

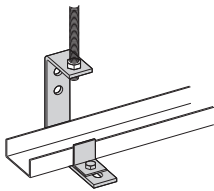

150 lb.
Safety Factor 3.0

Material	Channel Width							
	in.		mm		in.		mm	
	3	76	4	101	6	152		
Zinc Plated Steel	● 9ZN-1232-3		● 9ZN-1232-4		● 9ZN-1232-6			
	● 9ZN-1231-3 & 4		● 9ZN-1231-3 & 4		● 9ZN-1231-6			
HDGAF Steel (18 Ga.)	● 9G-1232-3		● 9G-1232-4		● 9G-1232-6			
	● 9G-1231-3 & 4		● 9G-1231-3 & 4		● 9G-1231-6			

Double Cable Channel Hanger

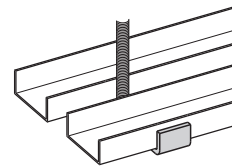

265 lb.
Safety Factor 3.0

All dimensions in shaded areas are millimeters unless otherwise specified.

● Green = Fastest shipped items ● Black = Normal lead-time items ● Red = Normally long lead-time items

Channel Cable Tray - Accessories

Cable Channel Covers

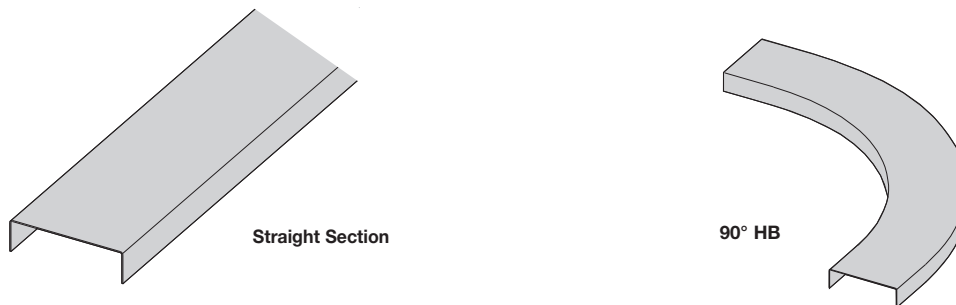

Covers Part Numbering

Prefix
Example: **80 8 A 40 - 04 - 144**

Cover Type	Detail	Material	Material Thickness	Tray Width	Item Description
80 = Solid	8 = Flanged	<ul style="list-style-type: none"> ● A = Aluminum ● G = Type 1 HDGAF ● P = Type 2 Pre-Galvanized ● SS4 = 304 Stainless Steel ● SS6 = 316 Stainless Steel 	<ul style="list-style-type: none"> 40 = .040 Aluminum 20 = 20 Gauge Pre-Galvanized, Gauge SS4 and SS6 18 = 18 Gauge HDGAF 	<ul style="list-style-type: none"> ● 03 = 3" ● 04 = 4" ● 06 = 6" 	For Straight Section Cover: Pre-Galv & Aluminum Only: 144 = 12 ft. 120 = 10 ft. Pre-Galv, HDGAF & Alum 72 = 6 ft. 60 = 5 ft. For fitting covers: Insert suffix of fitting to be covered.

All items normal lead time except for those indicated

Straight Section Part Number Material	Length	Channel Width								
		in.		mm		in.		mm		
<ul style="list-style-type: none"> ● Aluminum (.040) Solid 	12' (3.56m)	3	76	4	101	6	152	808A40-03-144	808A40-04-144	808A40-06-144
	10' (3.05m)							808A40-03-120	808A40-04-120	808A40-06-120
<ul style="list-style-type: none"> ● Type II Pre-Galvanized Steel (20 Ga.) Solid 	12' (3.56m)							808P20-03-144	808P20-04-144	808P20-06-144
	10' (3.05m)							808P20-03-120	808P20-04-120	808P20-06-120
<ul style="list-style-type: none"> ● Type I Hot Dip Galvanized Steel (18 Ga.) Solid 	12' (3.56m)							808G18-03-72	808G18-04-72	808G18-06-72
	10' (3.05m)							808G18-03-60	808G18-04-60	808G18-06-60

Fitting covers are available. To order, use the cover prefix followed by the fitting description. Ex: 808A40 - 03 - 90HB12.

Wrap-Around Cover Clamp

Wrap-Around Cover Clamps are used to securely hold a cover on cable channel in locations where strong winds can prevail.

- Furnished as one clamp with hardware.
- (*) Insert **A G P SS4 SS6**

Catalog No.	Channel Width	
	in.	mm
9(*)-9033	3	76
9(*)-9034	4	101
9(*)-9036	6	152

Combination Hold-Down & Cover Clamp

This clamp is used to hold both the cable channel and cover in place at the same time.

- Furnished as one clamp.
- Order 1/4" hardware separately.
- (*) Insert **A G P SS6**

Catalog No.	Channel Width	
	in.	mm
9(*)-9023	3	76
9(*)-9024	4	101
9(*)-9024	6	152

All dimensions in shaded areas are millimeters unless otherwise specified.

● Green = Fastest shipped items ● Black = Normal lead-time items ● Red = Normally long lead-time items

Channel Cable Tray - Accessories

Channel Cable Tray Connectors

Fast, economical, space saving Channel Cable Tray Connectors
 Patent No. 5,628,481; 5,782,439. Other patents pending.

Horizontal:

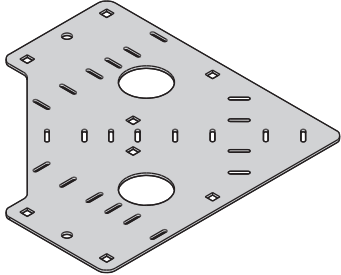

90° Bend

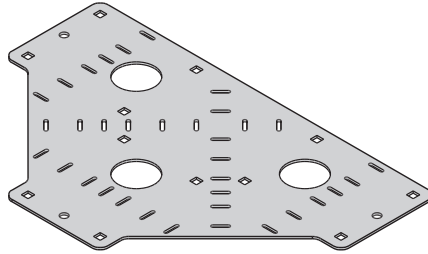

Tee

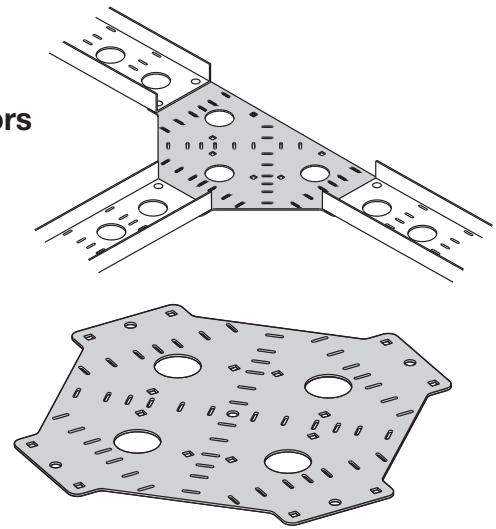

Cross

- Provides 0 or 6-inch radius connection for Cable Channel
- The Pivot Connector is available for custom angle adjustment
 - up to +/- 45° angle adjustment
 - order the desired quantity separately
- Slotted for easy cable fastening
- Shipped with the required hardware

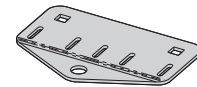

Pivot Connector

Vertical:

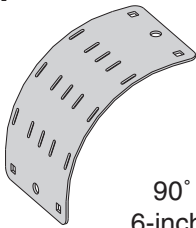

90° Bend
6-inch radius

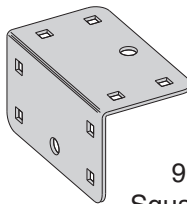

90° Vertical
Square Connector
0-inch radius

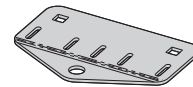

Pivot Connector

- Use the same part for VO and VI applications
- Slotted for easy cable fastening
- The Pivot Connector is available for custom angle adjustment (order separately)
- Shipped with the required hardware

Connector Part Numbering

Prefix

Example: **A CC - 04 - 90HC 060**

Material

- A = Aluminum
- G = Type 1 HDGAF

Tray Type

CC = Ventilated Cable Channel

Width

- 03 = 3"
- 04 = 4"
- 06 = 6"

Connector Type

- 90HC = 90° Horizontal
- HTC = Horizontal Tee
- HXC = Horizontal Cross
- 90VC = 90° Vertical
- PC = Pivot Connector

Radius

Horizontal Connectors
060 = 0" & 6" Radii
Vertical Connectors
00 = 0" Radius
06 = 6" Radius

All items normal lead time except for those indicated

● Green = Fastest shipped items ● Black = Normal lead-time items ● Red = Normally long lead-time items

Channel Cable Tray - Fittings

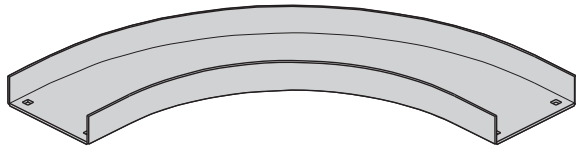

ACCN-04-90HB12
Non-Ventilated Horizontal Bend

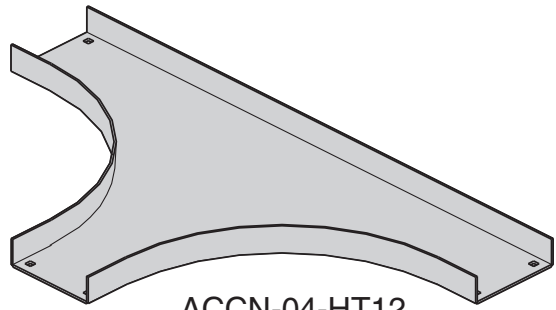

ACCN-04-HT12
Non-Ventilated Tee

Fittings engineered with 3" tangents for splicing integrity.

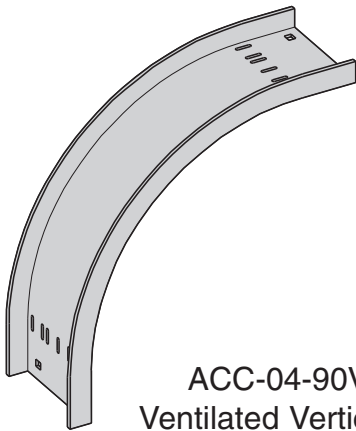

ACC-04-90VO12
Ventilated Vertical Bend

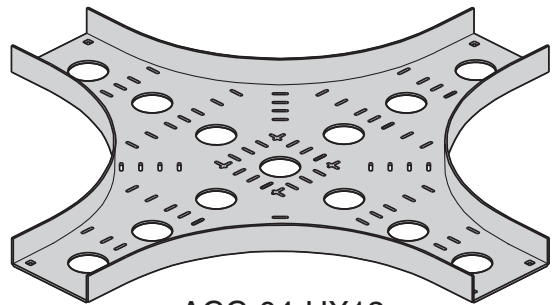

ACC-04-HX12
Ventilated Horizontal Cross

Fittings Part Numbering

Prefix
Example: **A CCN - 04 - 90 HB 24**

Material	Tray Type	Width	Angle	Fitting Type	Radius
<ul style="list-style-type: none"> ● A = Aluminum ● G = Type 1 HDGAF ● SS4 = 304 Stainless Steel ● SS6 = 316 Stainless Steel P = † 	<ul style="list-style-type: none"> ● *CC = Ventilated Cable Channel ● CCN = Non-ventilated Cable Channel 	<ul style="list-style-type: none"> ● 03 = 3" ● 04 = 4" ● 06 = 6" 	<ul style="list-style-type: none"> ● 30 = 30° ● 45 = 45° ● 60 = 60° ● 90 = 90° 	<ul style="list-style-type: none"> HB = Horizontal Bend HT = Horizontal Tee HX = Horizontal Cross VI = Vertical Inside Bend VO = Vertical Outside Bend 	<ul style="list-style-type: none"> ● 12 = 12" ● 24 = 24" ● 36 = 36" ● 48 = 48"

* Ventilated Cable Channel Fittings are available only in 12" and 24" radii.
 † - Due to multiple piece welded construction, P fittings are not available - substitute G.

All items normal lead time except for those indicated

● Green = Fastest shipped items ● Black = Normal lead-time items ● Red = Normally long lead-time items

Channel Cable Tray - Fittings

Horizontal Bends 90°, 60° (HB)

1 splice plate with hardware included.

Bend Radius R	Tray Width	90° Horizontal Bend Dimensions							
		Catalog No.	A		B		C		
in. mm	in. mm		in. mm	in. mm	in. mm	in. mm	in. mm	in. mm	
12	305	3 76	(Pre)-03-90HB12	16½ 419	16½ 419	16½ 419	16½ 419	16½ 419	
		4 101	(Pre)-04-90HB12	17 432	17 432	17 432	17 432		
		6 152	(Pre)-06-90HB12	18 457	18 457	18 457	18 457		
24	609	3 76	(Pre)-03-90HB24	28½ 723	28½ 723	28½ 723	28½ 723		
		4 101	(Pre)-04-90HB24	29 737	29 737	29 737	29 737		
		6 152	(Pre)-06-90HB24	30 762	30 762	30 762	30 762		
36	915	3 76	(Pre)-03-90HB36	40½ 1029	40½ 1029	40½ 1029	40½ 1029		
		4 101	(Pre)-04-90HB36	41 1041	41 1041	41 1041	41 1041		
		6 152	(Pre)-06-90HB36	42 1067	42 1067	42 1067	42 1067		
48	1218	3 76	(Pre)-03-90HB48	52½ 1334	52½ 1334	52½ 1334	52½ 1334		
		4 101	(Pre)-04-90HB48	53 1346	53 1346	53 1346	53 1346		
		6 152	(Pre)-06-90HB48	54 1372	54 1372	54 1372	54 1372		
60° Horizontal Bend									
12	305	3 76	(Pre)-03-60HB12	16¼ 412	9¾ 239	10¾ 273			
		4 101	(Pre)-04-60HB12	16¾ 422	9¾ 245	11½ 283			
		6 152	(Pre)-06-60HB12	17½ 445	10 254	11¾ 296			
24	609	3 76	(Pre)-03-60HB24	26¾ 819	15¾ 391	17¾ 451			
		4 101	(Pre)-04-60HB24	27 686	15¾ 397	18 450			
		6 152	(Pre)-06-60HB24	27¾ 708	16 406	18¾ 466			
36	915	3 76	(Pre)-03-60HB36	37 940	21¾ 543	24¾ 625			
		4 101	(Pre)-04-60HB36	37¾ 949	21¾ 549	25 635			
		6 152	(Pre)-06-60HB36	38¼ 972	22 559	25½ 648			
48	1218	3 76	(Pre)-03-60HB48	47¾ 1203	27¾ 695	31¾ 803			
		4 101	(Pre)-04-60HB48	47¾ 1216	27¾ 702	31¾ 810			
		6 152	(Pre)-06-60HB48	48¾ 1235	28 711	32½ 826			

All dimensions in shaded areas are millimeters unless otherwise specified.
(Pre) See page 105 for catalog number prefix.

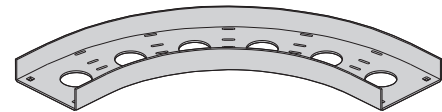

90° Horizontal Bend
Ventilated Horizontal Bend

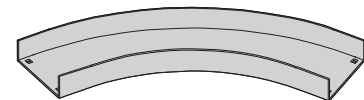
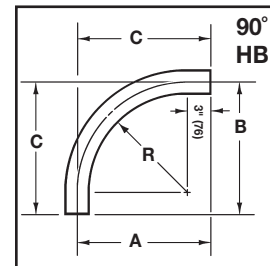

60° Horizontal Bend
Non-Ventilated Horizontal Bend

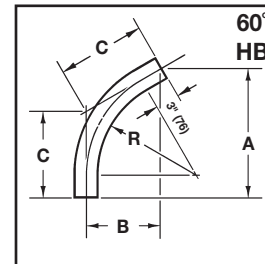

Channel Cable Tray - Fittings

Horizontal Bends 45°, 30° (HB)

1 splice plate with hardware included.



45° Horizontal Bend
Ventilated Horizontal Bend

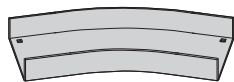
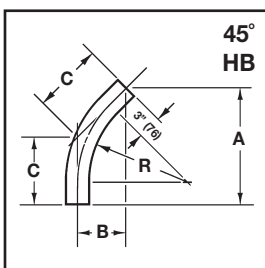

30° Horizontal Bend
Non-Ventilated Horizontal Bend

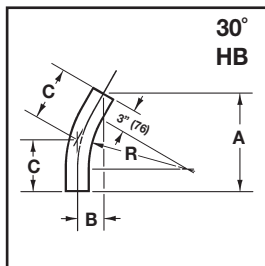

Bend Radius R	Tray Width		45° Horizontal Bend							
			Dimensions							
			Catalog No.		A		B		C	
in.	mm	in.	mm	in.	mm	in.	mm	in.	mm	
12	305	3	76	(Pre)-03-45HB12	14 ⁵ / ₈	371	6 ¹ / ₈	156	8 ⁵ / ₈	219
		4	101	(Pre)-04-45HB12	15	381	6 ¹ / ₄	159	8 ⁷ / ₈	225
		6	152	(Pre)-06-45HB12	15 ³ / ₄	400	6 ¹ / ₂	165	9 ¹ / ₄	235
24	609	3	76	(Pre)-03-45HB24	23 ¹ / ₈	587	9 ⁵ / ₈	244	13 ⁵ / ₈	346
		4	101	(Pre)-04-45HB24	23 ¹ / ₂	597	9 ³ / ₄	248	13 ³ / ₄	249
		6	152	(Pre)-06-45HB24	24 ¹ / ₈	613	10	254	14 ¹ / ₈	359
36	915	3	76	(Pre)-03-45HB36	31 ⁵ / ₈	803	13 ¹ / ₈	334	18 ⁵ / ₈	473
		4	101	(Pre)-04-45HB36	32	813	13 ¹ / ₄	337	18 ³ / ₄	476
		6	152	(Pre)-06-45HB36	32 ³ / ₄	832	13 ¹ / ₂	343	19 ¹ / ₈	486
48	1218	3	76	(Pre)-03-45HB48	40 ¹ / ₈	1019	16 ⁵ / ₈	422	23 ¹ / ₂	597
		4	101	(Pre)-04-45HB48	40 ¹ / ₂	1029	16 ³ / ₄	425	23 ³ / ₄	603
		6	152	(Pre)-06-45HB48	41 ¹ / ₈	1045	17	432	24 ¹ / ₈	613
30° Horizontal Bend										
12	305	3	76	(Pre)-03-30HB12	12 ³ / ₈	314	3 ¹ / ₄	83	6 ⁵ / ₈	168
		4	101	(Pre)-04-30HB12	12 ⁵ / ₈	321	3 ³ / ₈	86	6 ³ / ₄	171
		6	152	(Pre)-06-30HB12	13 ¹ / ₈	334	3 ¹ / ₂	89	7	178
24	609	3	76	(Pre)-03-30HB24	18 ³ / ₈	467	4 ⁷ / ₈	124	9 ⁷ / ₈	251
		4	101	(Pre)-04-30HB24	18 ⁵ / ₈	473	5	127	10	254
		6	152	(Pre)-06-30HB24	19 ¹ / ₈	486	5 ¹ / ₈	130	10 ¹ / ₄	260
36	915	3	76	(Pre)-03-30HB36	24 ³ / ₈	619	6 ¹ / ₂	165	13	330
		4	101	(Pre)-04-30HB36	24 ⁵ / ₈	626	6 ⁵ / ₈	168	13 ¹ / ₈	334
		6	152	(Pre)-06-30HB36	25 ¹ / ₈	638	6 ³ / ₄	171	13 ¹ / ₂	343
48	1218	3	76	(Pre)-03-30HB48	30 ³ / ₈	772	8 ¹ / ₈	207	16 ¹ / ₄	413
		4	101	(Pre)-04-30HB48	30 ⁵ / ₈	778	8 ¹ / ₄	210	16 ³ / ₈	416
		6	152	(Pre)-06-30HB48	31 ¹ / ₈	791	8 ³ / ₈	213	16 ⁵ / ₈	422

All dimensions in shaded areas are millimeters unless otherwise specified.
(Pre) See page 105 for catalog number prefix.

Channel Cable Tray - Fittings

Horizontal Tee (HT)

2 splice plates with hardware included.

Bend Radius R	Tray Width		Horizontal Tee Dimensions					
			Catalog No.	A		B		
				in.	mm	in.	mm	
12	305	3	76	(Pre)-03-HT12	16½	419	33	838
		4	101	(Pre)-04-HT12	17	432	34	864
		6	152	(Pre)-06-HT12	18	457	36	914
24	609	3	76	(Pre)-03-HT24	28½	723	57	1448
		4	101	(Pre)-04-HT24	29	737	58	1473
		6	152	(Pre)-06-HT24	30	762	60	1524
36	915	3	76	(Pre)-03-HT36	40½	1029	81	2057
		4	101	(Pre)-04-HT36	41	1041	82	2083
		6	152	(Pre)-06-HT36	42	1067	84	2134
48	1218	3	76	(Pre)-03-HT48	52½	1334	105	2667
		4	101	(Pre)-04-HT48	53	1346	106	2692
		6	152	(Pre)-06-HT48	54	1372	108	2743

All dimensions in shaded areas are millimeters unless otherwise specified.
(Pre) See page 105 for catalog number prefix.

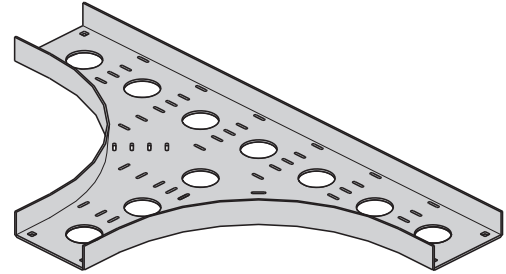

Horizontal Tee
Ventilated Horizontal Tee

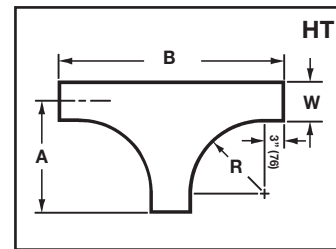

Horizontal Cross (HX)

3 splice plates with hardware included.

Bend Radius R	Tray Width		Horizontal Cross Dimensions					
			Catalog No.	A		B		
				in.	mm	in.	mm	
12	305	3	76	(Pre)-03-HX12	16½	419	33	838
		4	101	(Pre)-04-HX12	17	432	34	864
		6	152	(Pre)-06-HX12	18	457	36	914
24	609	3	76	(Pre)-03-HX24	28½	723	57	1448
		4	101	(Pre)-04-HX24	29	737	58	1473
		6	152	(Pre)-06-HX24	30	762	60	1524
36	915	3	76	(Pre)-03-HX36	40½	1029	81	2057
		4	101	(Pre)-04-HX36	41	1041	82	2083
		6	152	(Pre)-06-HX36	42	1067	84	2134
48	1218	3	76	(Pre)-03-HX48	52½	1334	105	2667
		4	101	(Pre)-04-HX48	53	1346	106	2692
		6	152	(Pre)-06-HX48	54	1372	108	2743

All dimensions in shaded areas are millimeters unless otherwise specified.
(Pre) See page 105 for catalog number prefix.

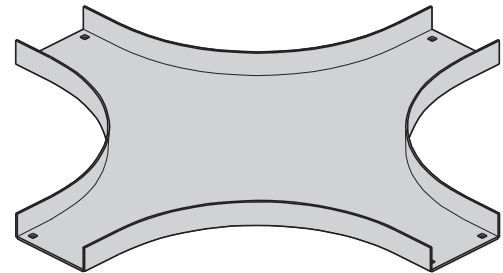

Horizontal Cross
Non-Ventilated Horizontal Cross

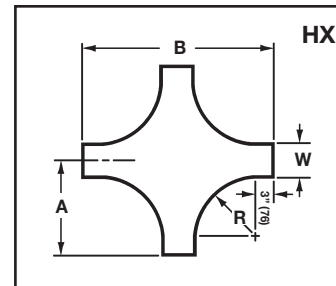

Channel Cable Tray - Fittings

Vertical Outside Bends 90°, 60° (VO)

1 splice plate with hardware included.

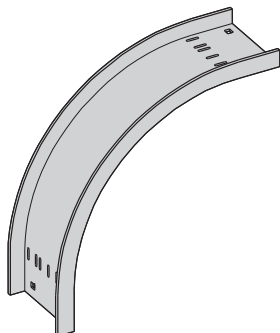

90° Vertical Outside Bend
Ventilated Vertical Outside Bend

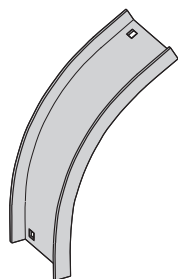
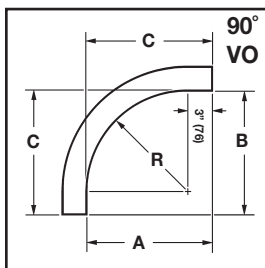

60° Vertical Outside Bend
Non-Ventilated Vertical Outside Bend

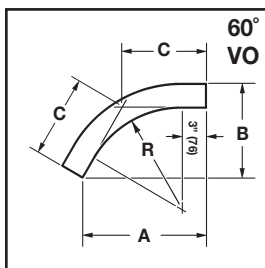

Bend Radius R	Tray Width		90° Vertical Outside Bend Dimensions							
			Catalog No.		A		B		C	
in.	mm	in.	mm		in.	mm	in.	mm	in.	mm
12	305	3	76	(Pre)-03-90VO12	15	381	15	381	15	381
		4	101	(Pre)-04-90VO12						
		6	152	(Pre)-06-90VO12						
24	609	3	76	(Pre)-03-90VO24	27	686	27	686	27	686
		4	101	(Pre)-04-90VO24						
		6	152	(Pre)-06-90VO24						
36	915	3	76	(Pre)-03-90VO36	39	991	39	991	39	991
		4	101	(Pre)-04-90VO36						
		6	152	(Pre)-06-90VO36						
48	1218	3	76	(Pre)-03-90VO48	51	1295	51	1295	51	1295
		4	101	(Pre)-04-90VO48						
		6	152	(Pre)-06-90VO48						
60° Vertical Outside Bend										
12	305	3	76	(Pre)-03-60VO12	14 ⁷ / ₈	378	8 ¹ / ₂	216	9 ⁷ / ₈	251
		4	101	(Pre)-04-60VO12						
		6	152	(Pre)-06-60VO12						
24	609	3	76	(Pre)-03-60VO24	25 ³ / ₈	645	14 ⁵ / ₈	372	16 ⁷ / ₈	428
		4	101	(Pre)-04-60VO24						
		6	152	(Pre)-06-60VO24						
36	915	3	76	(Pre)-03-60VO36	35 ⁵ / ₈	905	20 ⁵ / ₈	524	23 ³ / ₄	603
		4	101	(Pre)-04-60VO36						
		6	152	(Pre)-06-60VO36						
48	1218	3	76	(Pre)-03-60VO48	46 ¹ / ₈	1172	26 ⁵ / ₈	676	30 ³ / ₄	781
		4	101	(Pre)-04-60VO48						
		6	152	(Pre)-06-60VO48						

All dimensions in shaded areas are millimeters unless otherwise specified.

(Pre) See page 105 for catalog number prefix.

Channel Cable Tray - Fittings

Vertical Outside Bends 45°, 30° (VO)

1 splice plate with hardware included.

Bend Radius R	Tray Width	45° Vertical Outside Bend Dimensions							
		Catalog No.	A		B		C		
in. mm	in. mm		in. mm	in. mm	in. mm	in. mm	in. mm		
12 305	3 76	(Pre)-03-45VO12	13 ⁵ / ₈ 346	5 ⁵ / ₈ 143	8 203				
	4 101	(Pre)-04-45VO12							
	6 152	(Pre)-06-45VO12							
24 609	3 76	(Pre)-03-45VO24	22 ¹ / ₄ 565	9 ¹ / ₄ 235	13 330				
	4 101	(Pre)-04-45VO24							
	6 152	(Pre)-06-45VO24							
36 915	3 76	(Pre)-03-45VO36	30 ¹ / ₂ 775	12 ⁵ / ₈ 321	17 ⁷ / ₈ 454				
	4 101	(Pre)-04-45VO36							
	6 152	(Pre)-06-45VO36							
48 1218	3 76	(Pre)-03-45VO48	39 991	16 ¹ / ₈ 410	22 ⁷ / ₈ 581				
	4 101	(Pre)-04-45VO48							
	6 152	(Pre)-06-45VO48							
30° Vertical Outside Bend									
12 305	3 76	(Pre)-03-30VO12	11 ⁵ / ₈ 296	3 ¹ / ₈ 79	6 ¹ / ₄ 158				
	4 101	(Pre)-04-30VO12							
	6 152	(Pre)-06-30VO12							
24 609	3 76	(Pre)-03-30VO24	17 ¹ / ₂ 445	4 ⁷ / ₈ 124	9 ³ / ₈ 238				
	4 101	(Pre)-04-30VO24							
	6 152	(Pre)-06-30VO24							
36 915	3 76	(Pre)-03-30VO36	23 ¹ / ₂ 597	6 ³ / ₈ 162	12 ⁵ / ₈ 321				
	4 101	(Pre)-04-30VO36							
	6 152	(Pre)-06-30VO36							
48 1218	3 76	(Pre)-03-30VO48	29 ⁵ / ₈ 753	8 203	15 ⁷ / ₈ 403				
	4 101	(Pre)-04-30VO48							
	6 152	(Pre)-06-30VO48							

All dimensions in shaded areas are millimeters unless otherwise specified.
(Pre) See page 105 for catalog number prefix.

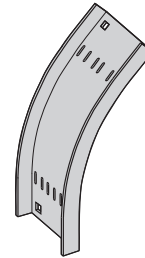

45° Vertical Outside Bend
Ventilated Vertical Outside Bend

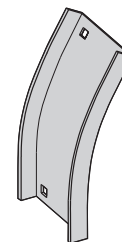
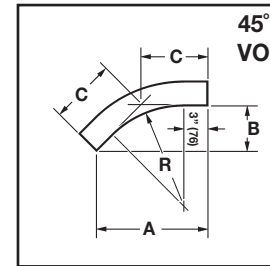

30° Vertical Outside Bend
Non-Ventilated Vertical Outside Bend

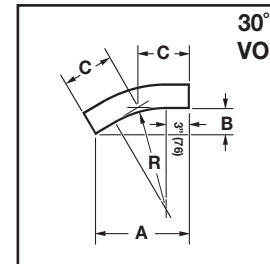

Channel Cable Tray - Fittings

Vertical Inside Bends 90°, 60° (VI)

1 splice plate with hardware included.

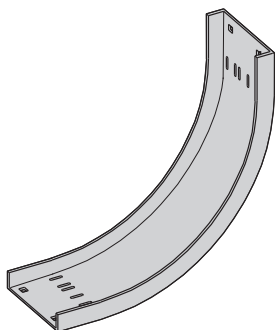

90° Vertical Inside Bend
Ventilated Vertical Inside Bend

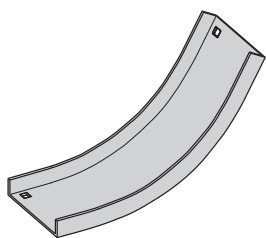
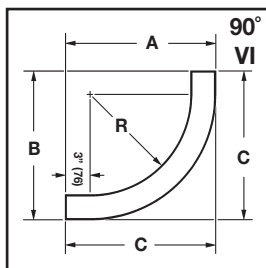

60° Vertical Inside Bend
Non-Ventilated Vertical Inside Bend

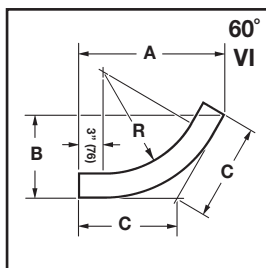

Bend Radius R	Tray Width		90° Vertical Inside Bend Dimensions								
			Catalog No.		A		B		C		
in.	mm	in.	mm	in.		mm		in.		mm	
12	305	3	76	(Pre)-03-90VI12		16 ¹ / ₄	413	16 ¹ / ₄	413	16 ¹ / ₄	413
		4	101	(Pre)-04-90VI12		16 ³ / ₄	425	16 ³ / ₄	425	16 ³ / ₄	425
		6	152	(Pre)-06-90VI12		16 ³ / ₄	425	16 ³ / ₄	425	16 ³ / ₄	425
24	609	3	76	(Pre)-03-90VI24		28 ¹ / ₄	718	28 ¹ / ₄	718	28 ¹ / ₄	718
		4	101	(Pre)-04-90VI24		28 ³ / ₄	730	28 ³ / ₄	730	28 ³ / ₄	730
		6	152	(Pre)-06-90VI24		28 ³ / ₄	730	28 ³ / ₄	730	28 ³ / ₄	730
36	915	3	76	(Pre)-03-90VI36		40 ¹ / ₄	1024	40 ¹ / ₄	1024	40 ¹ / ₄	1024
		4	101	(Pre)-04-90VI36		40 ³ / ₄	1035	40 ³ / ₄	1035	40 ³ / ₄	1035
		6	152	(Pre)-06-90VI36		40 ³ / ₄	1035	40 ³ / ₄	1035	40 ³ / ₄	1035
48	1218	3	76	(Pre)-03-90VI48		52 ¹ / ₄	1327	52 ¹ / ₄	1327	52 ¹ / ₄	1327
		4	101	(Pre)-04-90VI48		52 ³ / ₄	1340	52 ³ / ₄	1340	52 ³ / ₄	1340
		6	152	(Pre)-06-90VI48		52 ³ / ₄	1340	52 ³ / ₄	1340	52 ³ / ₄	1340
60° Vertical Inside Bend											
12	305	3	76	(Pre)-03-60VI12		16	406	9 ¹ / ₄	235	10 ⁵ / ₈	270
		4	101	(Pre)-04-60VI12		16 ¹ / ₂	419	9 ¹ / ₂	241	11	280
		6	152	(Pre)-06-60VI12		16 ¹ / ₂	419	9 ¹ / ₂	241	11	280
24	609	3	76	(Pre)-03-60VI24		26 ¹ / ₂	673	15 ¹ / ₄	387	17 ⁵ / ₈	448
		4	101	(Pre)-04-60VI24		26 ⁷ / ₈	683	15 ¹ / ₂	394	17 ⁷ / ₈	454
		6	152	(Pre)-06-60VI24		26 ⁷ / ₈	683	15 ¹ / ₂	394	17 ⁷ / ₈	454
36	915	3	76	(Pre)-03-60VI36		36 ³ / ₄	933	21 ¹ / ₄	540	24 ¹ / ₂	622
		4	101	(Pre)-04-60VI36		37 ¹ / ₈	943	21 ³ / ₈	543	24 ³ / ₄	629
		6	152	(Pre)-06-60VI36		37 ¹ / ₈	943	21 ³ / ₈	543	24 ³ / ₄	629
48	1218	3	76	(Pre)-03-60VI48		47 ¹ / ₈	1197	27 ¹ / ₈	689	31 ³ / ₈	797
		4	101	(Pre)-04-60VI48		47 ⁵ / ₈	1210	27 ¹ / ₂	699	31 ³ / ₄	806
		6	152	(Pre)-06-60VI48		47 ⁵ / ₈	1210	27 ¹ / ₂	699	31 ³ / ₄	806

All dimensions in shaded areas are millimeters unless otherwise specified.
(Pre) See page 105 for catalog number prefix.

Channel Cable Tray - Fittings

Vertical Inside Bends 45°, 30° (VI)

1 splice plate with hardware included.

Bend Radius R	Tray Width	45° Vertical Inside Bend Dimensions								
		Catalog No.		A		B		C		
in. mm	in. mm		in. mm	in. mm	in. mm	in. mm	in. mm	in. mm	in. mm	
12 305	3 76	(Pre)-03-45VI12	14 ¹ / ₂	368	6	152	8 ¹ / ₂	216		
	4 101	(Pre)-04-45VI12	14 ⁷ / ₈	373	6 ¹ / ₈	156	8 ³ / ₄	222		
	6 152	(Pre)-06-45VI12	14 ⁷ / ₈	378	6 ¹ / ₈	156	8 ³ / ₄	222		
24 609	3 76	(Pre)-03-45VI24	23	584	9 ¹ / ₂	241	13 ¹ / ₂	343		
	4 101	(Pre)-04-45VI24	23 ¹ / ₄	591	9 ⁵ / ₈	245	13 ⁵ / ₈	346		
	6 152	(Pre)-06-45VI24	23 ¹ / ₄	591	9 ⁵ / ₈	245	13 ⁵ / ₈	346		
36 915	3 76	(Pre)-03-45VI36	31 ³ / ₈	797	13	330	18 ³ / ₈	467		
	4 101	(Pre)-04-45VI36	31 ³ / ₄	806	13 ¹ / ₈	330	18 ⁵ / ₈	467		
	6 152	(Pre)-06-45VI36	31 ³ / ₄	806	13 ¹ / ₈	334	18 ⁵ / ₈	473		
48 1218	3 76	(Pre)-03-45VI48	39 ⁷ / ₈	1013	16 ¹ / ₂	419	23 ³ / ₈	594		
	4 101	(Pre)-04-45VI48	40 ³ / ₈	1026	16 ³ / ₄	425	23 ⁵ / ₈	600		
	6 152	(Pre)-06-45VI48	40 ³ / ₈	1026	16 ³ / ₄	425	23 ⁵ / ₈	600		
30° Vertical Inside Bend										
12 305	3 76	(Pre)-03-30VI12	12 ¹ / ₈	308	3 ¹ / ₈	83	6 ¹ / ₂	165		
	4 101	(Pre)-04-30VI12	12 ³ / ₈	314	3 ³ / ₈	86	6 ⁵ / ₈	163		
	6 152	(Pre)-06-30VI12	12 ³ / ₈	314	3 ³ / ₈	86	6 ⁵ / ₈	163		
24 609	3 76	(Pre)-03-30VI24	18 ¹ / ₈	461	4 ³ / ₄	121	9 ³ / ₄	248		
	4 101	(Pre)-04-30VI24	18 ³ / ₈	467	4 ⁷ / ₈	86	9 ⁷ / ₈	163		
	6 152	(Pre)-06-30VI24	18 ³ / ₈	314	4 ⁷ / ₈	86	9 ⁷ / ₈	163		
36 415	3 76	(Pre)-03-30VI36	24 ¹ / ₄	616	6 ¹ / ₂	165	13	330		
	4 101	(Pre)-04-30VI36	24 ¹ / ₂	622	6 ⁵ / ₈	168	13 ¹ / ₈	334		
	6 152	(Pre)-06-30VI36	24 ¹ / ₂	622	6 ⁵ / ₈	168	13 ¹ / ₈	334		
48 1218	3 76	(Pre)-03-30VI48	30 ³ / ₈	772	8 ¹ / ₈	207	16 ¹ / ₄	413		
	4 101	(Pre)-04-30VI48	30 ⁵ / ₈	778	8 ¹ / ₄	210	16 ³ / ₈	416		
	6 152	(Pre)-06-30VI48	30 ⁵ / ₈	778	8 ¹ / ₄	210	16 ³ / ₈	416		

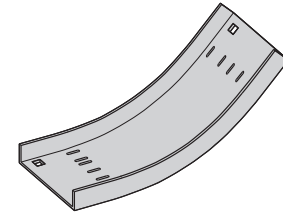

45° Vertical Inside Bend
Ventilated Vertical Inside Bend

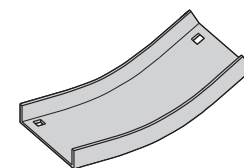
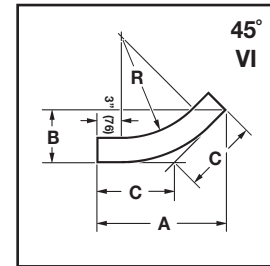

30° Vertical Inside Bend
Non-Ventilated Vertical Inside Bend

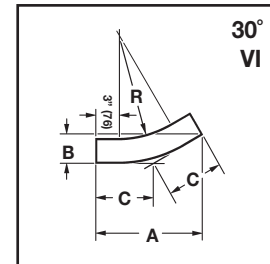

All dimensions in shaded areas are millimeters unless otherwise specified.
(Pre) See page 105 for catalog number prefix.

Section 1- Acceptable Manufacturers

- 1.01 Manufacturer: Subject to compliance with these specifications, channel cable tray systems shall be as manufactured by Cooper B-Line, Inc.

Section 2- Selection and Components

- 2.01 General: Except as otherwise indicated, provide ventilated metal channel cable trays, of types, classes and sizes indicated with splice connectors, fittings and all other necessary accessories for a complete system. Provide channel cable tray with rounded edges and smooth surfaces in compliance with applicable standards, and with the following additional requirements.

- 2.02 Materials and finishes: Material and finishes specifications for each channel cable tray are as follows:

1. Aluminum: Extruded components shall be made from Aluminum Association Alloy 6063. All fabricated parts shall be made from Aluminum Association Alloy 5052.
2. Pre-Galvanized Steel: Straight sections and fittings shall be made from structural quality mill galvanized 14 gauge steel meeting the properties of ASTM A653SS, coating designation G90.
3. Hot Dip Galvanized Steel: Straight sections and fittings shall be made from 14 gauge structural quality steel meeting the minimum mechanical properties of ASTM A1011 SS, Grade 33 and shall be hot-dip galvanized after fabrication in accordance with ASTM A123.
All hot dip galvanized after fabrication cable trays must be returned to point of manufacture after coating for inspection, conditioning and labeling.
4. Stainless Steel: Straight sections and fittings shall be AISI Type [304] [316].

- 2.03 Channel cable tray straight sections shall be constructed with ventilated flat bottom. Ventilating bottom shall be perforated with 2.25" diameter holes and have slots to facilitate the use of cable ties to secure the cables.

- 2.04 Straight sections shall be supplied in standard [12 foot] [10 foot (3 m)] lengths, except where shorter lengths are permitted to facilitate tray assembly as shown on drawings.

- 2.05 Ventilating straight sections shall have splice holes every 12 inches to simplify field modifications.

- 2.06 Channel cable tray width shall be [3] [4] [6] inches with a minimum loading depth of 1 1/4".

- 2.07 Fittings will have a minimum radius of [12] [24] [36] [48] inches.

- 2.08 Splice plates and hardware shall be included with each straight section and fitting.