

Straight Section Barriers

Cat. No.	Tray Loading Depth	Length
● C73A-144	3" (76.2mm)	144" (3.66m)
● C74A-144	4" (101.6mm)	144" (3.66m)
● C76A-144	6" (152.4mm)	144" (3.66m)
● C73A-120	3" (76.2mm)	120" (3.05m)
● C74A-120	4" (101.6mm)	120" (3.05m)
● C76A-120	6" (152.4mm)	120" (3.05m)

- Separates cable randomly in straight tray
- Furnished with 4 rung attachment clips, hardware and one splice

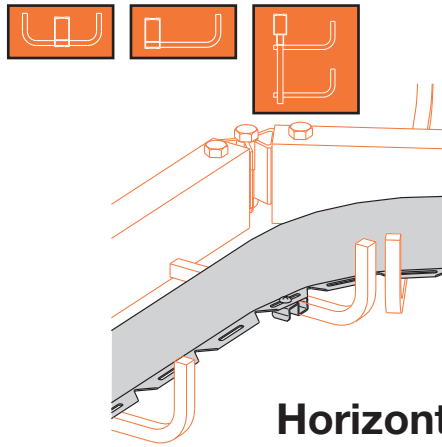

Horizontal Bend Barriers

Cat. No.	Tray Loading Depth
● C73A-90HBFL	3" (76.2mm)
● C74A-90HBFL	4" (101.6mm)
● C76A-90HBFL	6" (152.4mm)

- Separates cable randomly
- Standard Length: 72" (6 ft.) (1.8m)
- Horizontal bend barriers are flexible in order to conform to any horizontal bend
- Furnished with 3 rung attachment clips, hardware and one splice

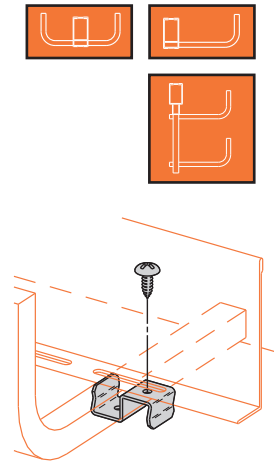

Rung Attachment

Cat. No.
● CZNM-RC

- Used to attach barrier strips without screwing into rungs
- One #10 x 1/2" self-drilling screw included



K1 Cover

Bottom Rung Data-Track™		
Cat. No.	Overall Width	
	in.	(mm)
● C(*)K1F-DB-06-(length)	9.000	(228.6)
● C(*)K1F-DB-09-(length)	12.000	(304.8)
● C(*)K1F-DB-12-(length)	15.000	(381.0)
● C(*)K1F-DB-18-(length)	19.375	(492.1)
● C(*)K1F-DB-24-(length)	25.375	(644.5)

Top Rung Data-Track		
Cat. No.	Overall Width	
	in.	(mm)
● C(*)K1F-DT-06-(length)	7.375	(187.3)
● C(*)K1F-DT-09-(length)	10.375	(263.5)
● C(*)K1F-DT-12-(length)	13.375	(339.7)
● C(*)K1F-DT-18-(length)	19.375	(492.1)
● C(*)K1F-DT-24-(length)	25.375	(644.5)

(*) Insert "A" for .040" aluminum or "P" for 20 Ga. pre-galvanized steel.

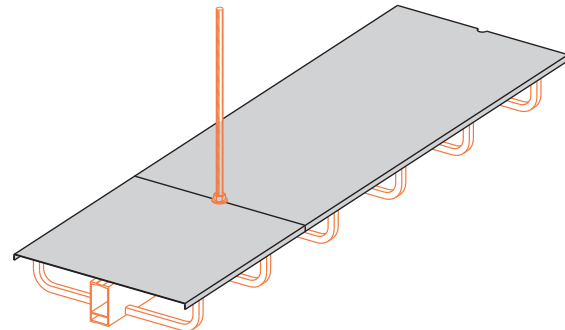

- Available in .040 (1mm) aluminum
- Available in 20 (.9mm) gauge pre-galvanized steel.
- Notched for 1/2" ATR (hardware not included).
- Full 1/2" flange.
- Available in 10 ft. (120") (3.0m) and 12 ft. (144") (3.7m) sections.

Length Suffix	Cover Length
● -120	120" (10 ft.) (3.05m)
● -144	144" (12 ft.) (3.66m)

● Green = Fastest shipped items ● Black = Normal lead-time items ● Red = Normally long lead-time items