

Unbalanced Loading - The Study

To better understand uneven loading on center rail systems, Cooper B-Line ran a series of tests on Data-Track™. Tests were performed with supports on twelve foot centers using 1/2" threaded rod. The maximum allowable tilt was set at six degrees. This angle was chosen purely for aesthetic reasons. It is nowhere near structural failure, but the point at which it started to look unacceptable.

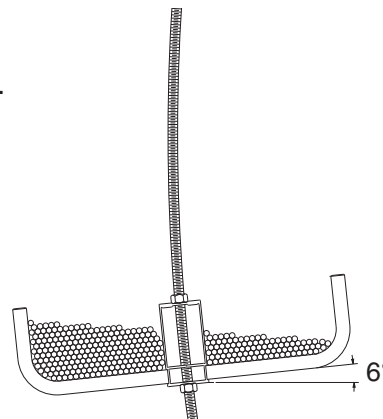

Center rail systems can be supported using different processes. For B-Line's study, the following four were used:

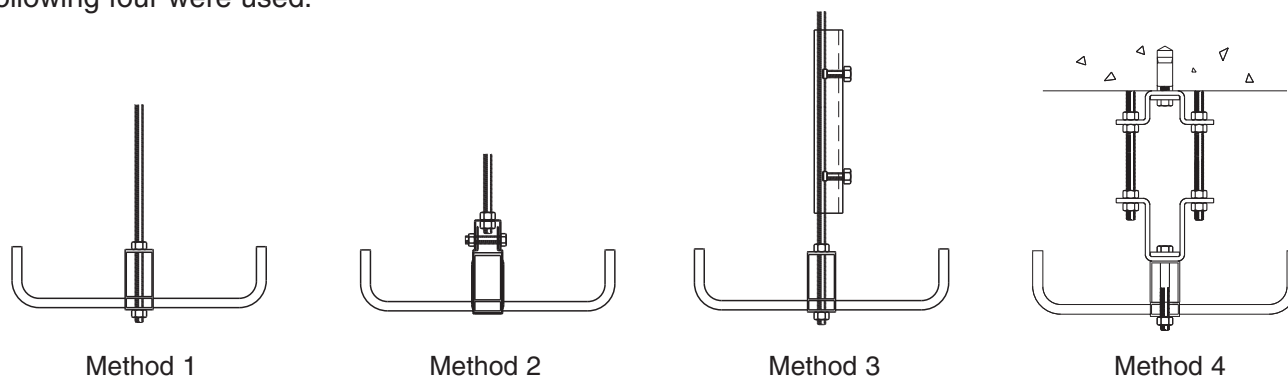

- Method 1: 1/2" ATR passing through splice hangers (CAS-SB) with hex nuts on top and bottom.
- Method 2: 1/2" ATR with clevis (CZNH-CD).
- Method 3: 1/2" ATR reinforced with rod stiffener (B22 channel rod stiffener and SC228 hanger rod stiffener assembly).
- Method 4: CZN-DRS-72 special purpose support assembly.

Combining the two loading groups and the four support methods, testing revealed the following:

<u>Group 1-Under 25 lbs/ft</u>	<u>Loading Balance %*</u>
Method 1	65/35
Method 2	65/35
Method 3	80/20
Method 4	100/0

<u>Group 2 - 25 lbs/ft to 50 lbs/ft</u>	<u>Loading Balance %*</u>
Method 1	60/40
Method 2	55/45
Method 3	65/35
Method 4	80/20

As a reminder, failure was defined as a 6° horizontal tilt. The supports were on 12 ft centers and the ATR drops were 6 ft. Cable loading was estimated for category 5 cable weighing .021 lbs/ft with a cross-sectional area of .0492 square inches. This information should be beneficial when considering eccentric loading and center rail systems.

*Defined as percentage of total cable load allowed on one side of the tray.