

Series 2, 3, 4, & 5 Aluminum - Straight Sections

6" NEMA VE 1 Loading Depth
7" Side Rail Height

Straight Section Part Numbering

Prefix

Example: 37 A 09 - 24 - 240

Series

- 37
- 47
- H47†
- 57†

Material

- A = Aluminum

*Type

- Ladder-
- 06 = 6" rung spacing
- 09 = 9" rung spacing
- 12 = 12" rung spacing

*Width

- 06 = 6"
- 09 = 9"
- 12 = 12"
- 18 = 18"
- 24 = 24"
- 30 = 30"
- 36 = 36"

Length

- | | |
|------------------|-----|
| ● ① 240 = 20 ft. | 37 |
| ● ② 144 = 12 ft. | |
| ● ① 240 = 20 ft. | 47 |
| ● ② 288 = 24 ft. | |
| ● ① 240 = 20 ft. | H47 |
| ● ② 300 = 25 ft. | |
| ● ① 360 = 30 ft. | 57 |
| ● ② 300 = 25 ft. | |

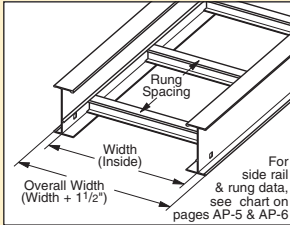

- Trough-
- 6" thru 36" wide
- VT = Vented Trough
- ST = Non-Ventilated Trough

† H47A & 57A only available in ladder type 9" and 12" rung spacing. See page 363.

- ① Primary Length.
- ② Secondary Length.

See page 39 for explanation of lengths.

See page 362 for additional rung options. *Special sizes available.



Ladder Type
(Specify Rung Spacing)

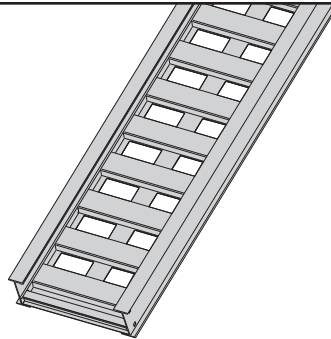

Ventilated Trough

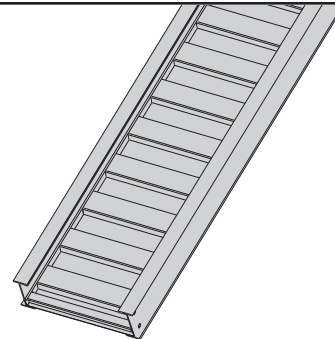

Non-Ventilated Trough

57A available in
(9" & 12" rung spacing in
12" to 36" widths)

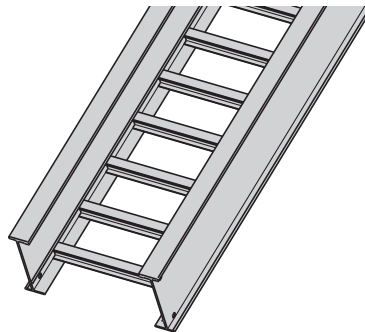

● Green = Fastest shipped items ● Black = Normal lead-time items ● Red = Normally long lead-time items

Series 2, 3, 4, & 5 Aluminum - Straight Sections

6" NEMA VE 1 Loading Depth 7" Side Rail Height

Values are based on simple beam tests per NEMA VE 1 on 36" wide cable tray with rungs spaced on 12" centers. Cable trays will support without collapse a 200 lb. (90.7 kg) concentrated load over and above published loads. Published load safety factor is 1.5. To convert 1.5 safety factor to 2.0, multiply the published load by 0.75. To obtain mid-span deflection, multiply a load by the deflection multiplier. Cable tray must be supported on spans shorter than or equal to the length of the cable tray being installed.

Individual rungs will support without collapse a 200 lb. (90.7 kg) concentrated load applied at the mid-span of the rung, over and above the NEMA rated cable load with a 1.5 safety factor for highlighted NEMA spans and loads. See table on page 367 for rung capacities.

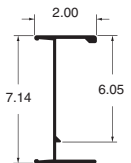
B-Line Series	Side Rail Dimensions	NEMA, CSA & UL Classifications	Span ft	Load lbs/ft	Deflection Multiplier	Design Factors for Two Rails	Span meters	Load kg/m	Deflection Multiplier	Design Factors for Two Rails
37		NEMA: 20B, 16C CSA: 106 kg/m 6.1m UL Cross-Sectional Area: 1.50 in ²	12	222	0.0035	Area=1.81 in ² Sx=3.77 in ³ Ix=13.50 in ⁴	3.7	331	0.059	Area=11.68 cm ² Sx=61.78 cm ³ Ix=561.91 cm ⁴
			14	163	0.0064		4.3	243	0.109	
			16	125	0.011		4.9	186	0.186	
			18	99	0.017		5.5	147	0.299	
			20	80	0.027		6.1	119	0.455	
			22	66	0.039		6.7	98	0.666	

When trays are used in continuous spans, the deflection of the tray is reduced by as much as 50%. Design factors: Ix = Moment of Inertia, Sx = Section Modulus.

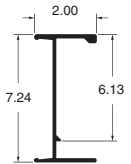
B-Line Series	Side Rail Dimensions	NEMA, CSA & UL Classifications	Span ft	Load lbs/ft	Deflection Multiplier	Design Factors for Two Rails	Span meters	Load kg/m	Deflection Multiplier	Design Factors for Two Rails
47		NEMA: 20C CSA: 142 kg/m 6.1m UL Cross-Sectional Area: 2.00 in ²	14	204	0.0048	Area=2.38 in ² Sx=4.94 in ³ Ix=17.88 in ⁴	4.3	304	0.083	Area=15.35 cm ² Sx=80.95 cm ³ Ix=744.22 cm ⁴
			16	156	0.0082		4.9	233	0.141	
			18	123	0.0132		5.5	184	0.225	
			20	100	0.0201		6.1	149	0.344	
			22	83	0.0295		6.7	123	0.503	
			24	69	0.0418		7.3	103	0.713	

When trays are used in continuous spans, the deflection of the tray is reduced by as much as 50%. Design factors: Ix = Moment of Inertia, Sx = Section Modulus.

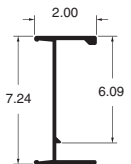
B-Line Series	Side Rail Dimensions	NEMA, CSA & UL Classifications	Span ft	Load lbs/ft	Deflection Multiplier	Design Factors for Two Rails	Span meters	Load kg/m	Deflection Multiplier	Design Factors for Two Rails
H47		NEMA: 20C+ CSA: 241 kg/m 6.1m UL Cross-Sectional Area: 2.00 in ²	16	233	0.0064	Area=3.04 in ² Sx=6.10 in ³ Ix=22.91 in ⁴	4.9	346	0.110	Area=19.61 cm ² Sx=99.96 cm ³ Ix=953.59 cm ⁴
			18	184	0.010		5.5	274	0.176	
			20	149	0.016		6.1	222	0.268	
			22	123	0.023		6.7	183	0.393	
			24	103	0.033		7.3	154	0.556	
			25	95	0.038		7.6	142	0.655	

When trays are used in continuous spans, the deflection of the tray is reduced by as much as 50%. Design factors: Ix = Moment of Inertia, Sx = Section Modulus.

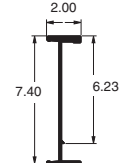
B-Line Series	Side Rail Dimensions	NEMA, CSA & UL Classifications	Span ft	Load lbs/ft	Deflection Multiplier	Design Factors for Two Rails	Span meters	Load kg/m	Deflection Multiplier	Design Factors for Two Rails
57		NEMA: 20C+ CSA: 152 kg/m 9.1m UL Cross-Sectional Area: 2.00 in ²	20	232	0.011	Area=4.22 in ² Sx=7.73 in ³ Ix=32.86 in ⁴	6.1	345	0.187	Area=27.23 cm ² Sx=126.67 cm ³ Ix=1367.74 cm ⁴
			22	192	0.016		6.7	285	0.274	
			24	161	0.023		7.3	240	0.388	
			26	136	0.031		7.9	202	0.534	
			28	117	0.042		8.5	174	0.718	
			30	102	0.055		9.1	152	0.947	

When trays are used in continuous spans, the deflection of the tray is reduced by as much as 50%. Design factors: Ix = Moment of Inertia, Sx = Section Modulus.

Series 2, 3, 4, & 5 Aluminum - Straight Sections

6" NEMA VE 1 Loading Depth 8" Side Rail Height

Straight Section Part Numbering

Prefix

Example: **S8 A 09 - 24 - 240**

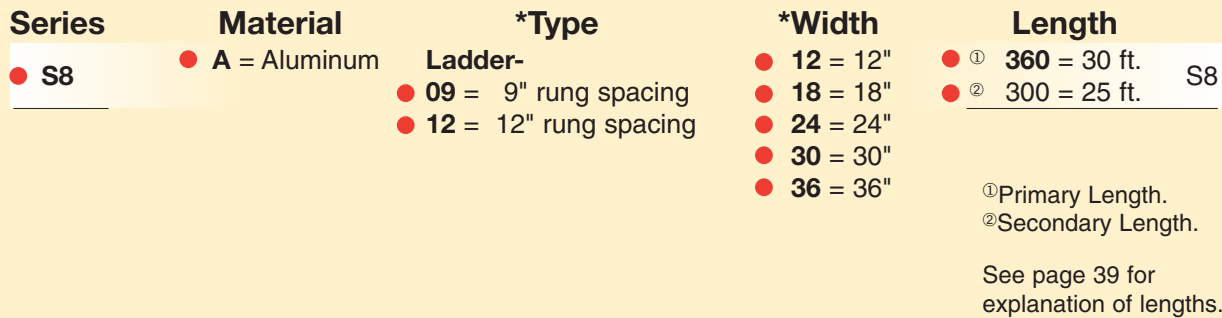

See page 362 for additional rung options. *Special sizes available.

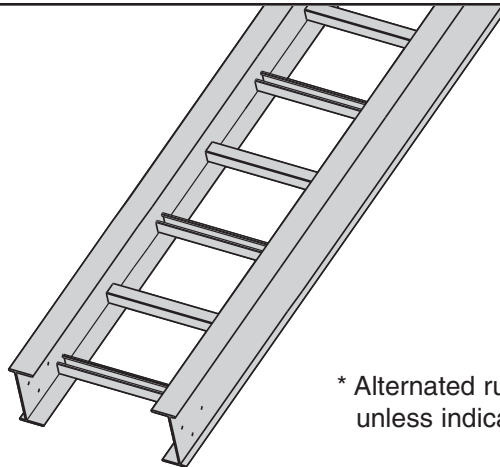
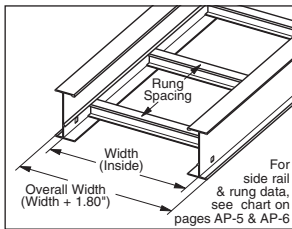

* Alternated rung unless indicated.

Values are based on simple beam tests per NEMA VE 1 on 36" wide cable tray with rungs spaced on 12" centers. Cable trays will support without collapse a 200 lb. (90.7 kg) concentrated load over and above published loads. Published load safety factor is 1.5. To convert 1.5 safety factor to 2.0, multiply the published load by 0.75. To obtain mid-span deflection, multiply a load by the deflection multiplier. Cable tray must be supported on spans shorter than or equal to the length of the cable tray being installed.

Individual rungs will support without collapse a 200 lb. (90.7 kg) concentrated load applied at the mid-span of the rung, over and above the NEMA rated cable load with a 1.5 safety factor for highlighted NEMA spans and loads. See table on page 367 for rung capacities.

B-Line Series	Side Rail Dimensions	NEMA, CSA & UL Classifications	Span ft	Load lbs/ft	Deflection Multiplier	Design Factors for Two Rails	Span meters	Load kg/m	Deflection Multiplier	Design Factors for Two Rails
S8A		NEMA: 20C+	20	363	0.007	Area=5.50 in ² Sx=15.39 in ³ Ix=55.35 in ⁴	6.1	540	0.111	Area=35.48 cm ² Sx=252.20 cm ³ Ix=2303.84 cm ⁴
		CSA: 240 kg/m 9.1m	22	300	0.010		6.7	446	0.163	
		UL Cross-Sectional	24	252	0.013		7.3	375	0.230	
		Area: 2.00 in ²	26	215	0.019		7.9	320	0.317	
			28	185	0.025		8.5	276	0.427	
	30	161	0.033	9.1	240	0.562				

● Green = Fastest shipped items ● Black = Normal lead-time items ● Red = Normally long lead-time items

The following is a list of accessories and fittings that can be provided with S8A tray.
For more information on these items, contact the Engineering Department at Cooper B-Line.

Fittings ●

Horizontal Bends

- 30° Bends with 24", 36", or 48" radius
- 45° Bends with 24", 36", or 48" radius
- 60° Bends with 24", 36", or 48" radius
- 90° Bends with 24", 36", or 48" radius

Horizontal Tees

With 24", 36", or 48" radius

Vertical Outside Bends

- 30° Bends with 24", 36", or 48" radius
- 45° Bends with 24", 36", or 48" radius
- 60° Bends with 24", 36", or 48" radius
- 90° Bends with 24", 36", or 48" radius

Vertical Inside Bends

- 30° Bends with 24", 36", or 48" radius
- 45° Bends with 24", 36", or 48" radius
- 60° Bends with 24", 36", or 48" radius
- 90° Bends with 24", 36", or 48" radius

Reducing Fittings

Accessories ●

- Splice Plate - 9A-1008**
- Expansion Splice Plate - 9A-1018**
- Horizontal Adjustable Splice Plate - 9A-1038**
- Vertical Adjustable Splice Plate - 9A-1028**
- Hold Down Clamps - 9ZN-1281, 9G-1281, 9A-1281**
- Guides - S9ZN-1202, S9G-1202**
- Step Down Splice Plate - 9A-1050, 9A-1078**
- Other Accessories Include:**
 - Offset Splice Plates**
 - Blind Ends**

● Green = Fastest shipped items ● Black = Normal lead-time items ● Red = Normally long lead-time items