

Series 2, 3, 4, & 5 Aluminum - Accessories

Wedge Lock Splice Plates (Excluding H46, H47 & 57 Series)

- Standard 4-hole pattern (except 9A-1007).
- Furnished in pairs, with hardware.
- One pair including hardware provided with each section.
- Boxed in pairs with hardware.
- For field installation drill $\frac{13}{32}$ " hole.

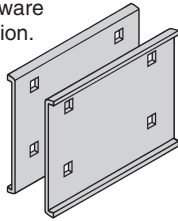

Catalog No.	Height	
	in.	mm
● 9A-1004	4	101
● 9A-1005	5	127
● 9A-1006	6	152
● 9A-1007	7	178

H46A, H47A and 57A Mid-Span Splice

- Standard for H46A, H47A and 57A straight sections.
- Six bolt design $\frac{1}{2}$ " Stainless Steel Type 316 hardware standard.
- Available on ladder bottoms only. 09 and 12" rung spacing.
- Furnished in pairs with hardware.

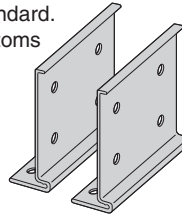

Tray Series	Catalog No.
H46A	● 9A-6006
H47A, 57A	● 9A-6007

Expansion Splice Plates

- Expansion plates allow for one inch expansion or contraction of the cable tray, or where expansion joints occur in the supporting structure.
- Furnished in pairs with hardware.
- **Bonding Jumpers are required on each siderail. Order Separately.**

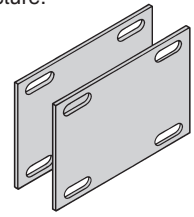

Catalog No.	Height	
	in.	mm
● 9A-1014	4	101
● 9A-1015	5	127
● 9A-1016	6	152
● 9A-1017	7	178

Universal Splice Plates

- Used to splice to existing cable tray systems.
- Furnished in pairs with hardware.

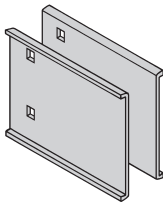

Catalog No.	Height	
	in.	mm
● 9A-1004- $\frac{1}{2}$	4	101
● 9A-1005- $\frac{1}{2}$	5	127
● 9A-1006- $\frac{1}{2}$	6	152
● 9A-1007- $\frac{1}{2}$	7	178

Step Down Splice Plates

- These splice plates are offered for connecting cable tray sections having side rails of different heights.
- Furnished in pairs with hardware.

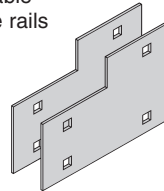

Catalog No.	Height	
	in.	mm
● 9A-1045	5 to 4	127 to 101
● 9A-1046	6 to 4	152 to 101
● 9A-1060	6 to 5	152 to 127
● 9A-1047	7 to 4	178 to 101
● 9A-1061	7 to 5	178 to 127
● 9A-1062	7 to 6	178 to 152

Vertical Adjustable Splice Plates

- These plates provide for changes in elevation that do not conform to standard vertical fittings.
- Furnished in pairs with hardware.
- **Bonding Jumper not required.**

Requires supports within 24" on both sides, per NEMA VE 2.

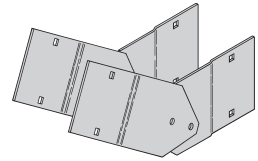

Catalog No.	Height	
	in.	mm
● 9A-1024	4	101
● 9A-1025	5	127
● 9A-1026	6	152
● 9A-1027	7	178

Horizontal Adjustable Splice Plates

- Offered to adjust a cable tray run for changes in direction in a horizontal plane that do not conform to standard horizontal fittings.
- Furnished in pairs with hardware.
- New design bonding jumpers **not** required.
- (X) Insert 4, 5, 6 or 7 for side rail height.

9A-103(X)-12 or 9A-103(X)-36
One pair splice plates with extensions.

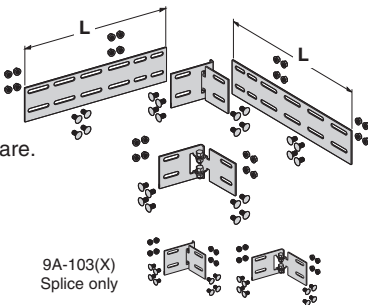

Catalog No.	Cable Tray End Cut	Tray Width	'L'
● 9A-103(X)	Mitered	Thru 36"	N/A
● 9A-103(X)-12	Not mitered	Thru 12"	16"
● 9A-103(X)-36	Not mitered	Thru 36"	41"

Requires supports within 24" on both sides, per NEMA VE 2.

Branch Pivot Connectors

- Branch from existing cable tray runs at any point.
- Pivot to any required angle.
- UL Classified for grounding (bonding jumper not required).
- Furnished in pairs with hardware.

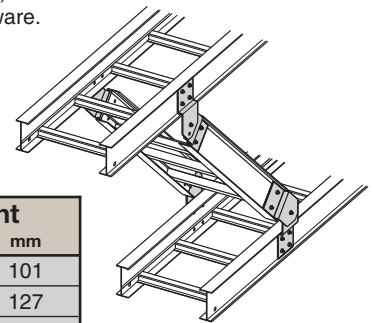

Catalog No.	Height	
	in.	mm
● 9A-2044	4	101
● 9A-2045	5	127
● 9A-2046	6	152
● 9A-2047	7	178

● Green = Fastest shipped items ● Black = Normal lead-time items ● Red = Normally long lead-time items

Series 2, 3, 4, & 5 Aluminum - Accessories

Series 2, 3, 4, & 5 Aluminum

Cross Connector Bracket

- For field connecting crossing section.
- Furnished in pairs with 3/8" hardware.

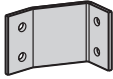
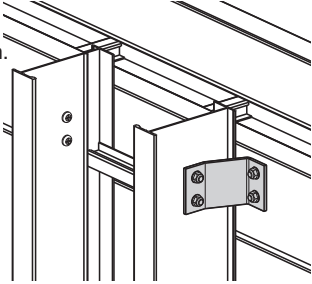
Catalog No. ● 9A-1240

Tray Hardware

For field installation drill 13/32" hole.

Standard Tray Hardware

Catalog No. ● **SNCB 3/8" x 3/4" Znpl** Square Neck Carriage Bolt ASTM A307 Grade A

Catalog No. ● **SFHN 3/8"-16 Znpl** Serrated Flange Hex Nut ASTM A563 Grade A

Finish: Zinc Plated ASTM B633, SC1

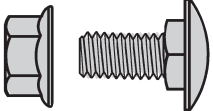

Offset Reducing Splice Plate

- This plate is used for joining cable trays having different widths. When used in pairs they form a straight reduction; when used singly with a standard splice plate, they form an offset reduction.
- Furnished as one plate with hardware.
- (‡) Insert reduction

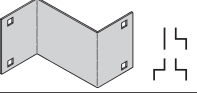

Catalog No.	Height	
	in.	mm
● 9A-1064-(‡)	4	101
● 9A-1065-(‡)	5	127
● 9A-1066-(‡)	6	152
● 9A-1067-(‡)	7	178

Optional Tray Hardware

Catalog No. ● **SNCB 3/8" x 3/4" SS6** Square Neck Carriage Bolt AISI 316 Stainless Steel

Catalog No. ● **SFHN 3/8"-16 SS6** Serrated Flange Hex Nut AISI 316 Stainless Steel

To order optional 316 Stainless Steel hardware add SS6 suffix to part number
Example: 9A-1004SS6

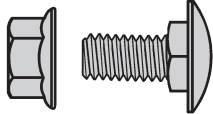

Tray to Box Splice Plates

- Used to attach the end of a cable tray run to a distribution box or control panel.
- Furnished in pairs with hardware.

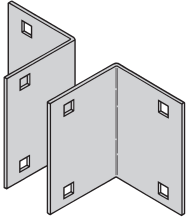

Catalog No.	Height	
	in.	mm
● 9A-1054	4	101
● 9A-1055	5	127
● 9A-1056	6	152
● 9A-1057	7	178

Frame Type Box Connector

- Designed to attach the end of a cable tray run to a distribution cabinet or control center to help reinforce the box at the point of entry.
- Furnished with tray connection hardware.
- (‡) Insert tray width

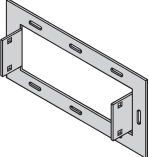

Catalog No.	Height	
	in.	mm
● 9A-1074-(‡)	4	101
● 9A-1075-(‡)	5	127
● 9A-1076-(‡)	6	152
● 9A-1077-(‡)	7	178

Blind End

- This plate forms a closure for a dead end cable tray.
- Furnished as one plate with hardware.
- (‡) Insert tray width

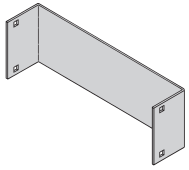

Catalog No.	Height	
	in.	mm
● 9A-1084-(‡)	4	101
● 9A-1085-(‡)	5	127
● 9A-1086-(‡)	6	152
● 9A-1087-(‡)	7	178

Conduit to Cable Tray Adaptors

- Assembly required.
- Mounting hardware included.
- Conduit clamps provided.
- (‡) = Conduit size (1/2" thru 4").

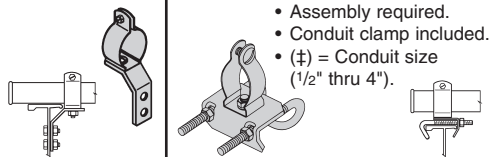

Catalog No. ● 9ZN-1150-(‡) **Catalog No.** ● 9ZN-1155-(‡)

Conduit to Cable Tray Adaptor

- For easy attachment of conduit terminating at a cable tray.
- Use on aluminum or steel cable trays.

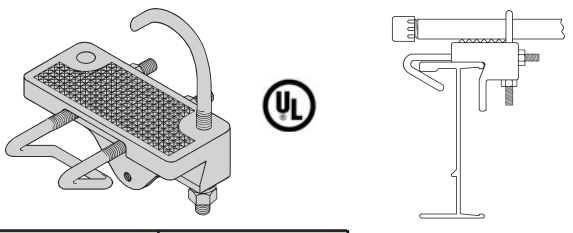

UL

Aluminum I-Beam

Catalog No.	Conduit Size	
	in.	mm
● 9G-1158-1/2, 3/4	1/2, 3/4	15, 20
● 9G-1158-1, 1 1/4	1, 1 1/4	25, 32
● 9G-1158-1 1/2, 2	1 1/2, 2	40, 50
● 9G-1158-2 1/2, 3	2 1/2, 3	65, 80
● 9G-1158-3 1/2, 4	3 1/2, 4	90, 100

Cable Tie (Ladder Tray)

Nylon ties provide easy attachment of cable to ladder rungs; maximum cable O.D. is 3" (76mm).

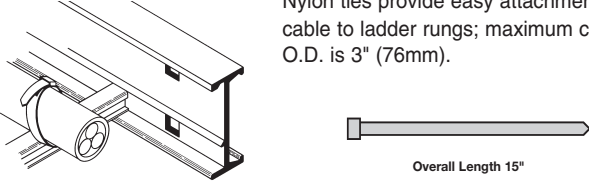

Overall Length 15"

Catalog No. ● 99-2125-15

● Green = Fastest shipped items ● Black = Normal lead-time items ● Red = Normally long lead-time items

Series 2, 3, 4, & 5 Aluminum - Accessories

Ladder Drop-Out

- Specially-designed Ladder Drop-Outs provide a rounded surface with 4" (101 mm) radius to protect cable as it exits from the cable tray, preventing damage to insulation. The drop-out will attach to any desired rung.
- (‡) Insert tray width

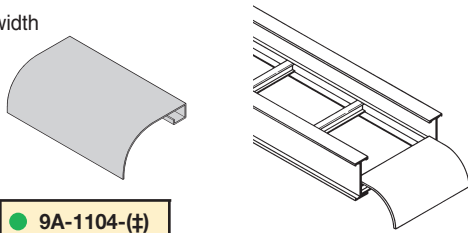

Catalog No. ● 9A-1104-(‡)

Trough Drop-Out & Drop-Out Bushing

- These devices provide a rounded surface to protect cable as it exits from the trough-type cable tray.
- Hardware is included for attachment of the trough bottom drop-out.
- (‡) Insert tray width

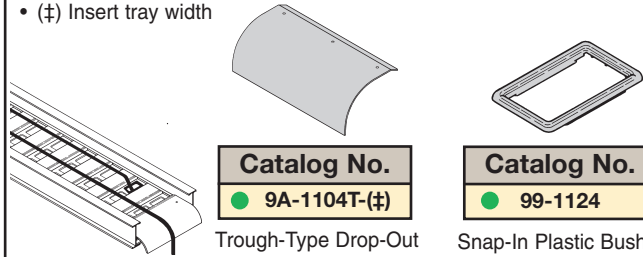

Catalog No.

● 9A-1104T-(‡)

Trough-Type Drop-Out

Catalog No.

● 99-1124

Snap-In Plastic Bushing

Barriers

Straight Section

- Standard length: 120" (3 m) 144" (12 ft.).
- Order catalog number based on loading depth.
- Furnished with four #10 x 1/2" plated self-drilling screws and a 99-9982 splice.

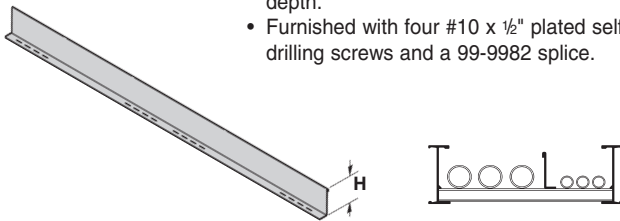

Catalog No.	Side Rail Height		Loading Depth 'H'	
	in.	mm	in.	mm
● 73A-Length	4	101	3	76
● 74A-Length	5	127	4	101
● 75A-Length	6	152	5	127
● 76A-Length	7	178	6	152

Length =
144 for 12"
or
120 for 10"

Horizontal Bend

- Horizontal Bend Barriers are flexible in order to conform to any horizontal fitting radius. Cut to length.
- Order catalog number based on loading depth.
- Furnished with three #10 x 1/2" zinc plated self-drilling screws and a 99-9982 Barrier Strip Splice.
- Standard length is 72" (6 ft.), sold individually.

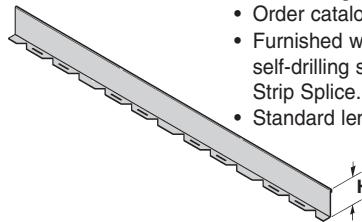

Catalog No.	Side Rail Height		Loading Depth 'H'	
	in.	mm	in.	mm
● 73A-90HBFL	4	101	3	76
● 74A-90HBFL	5	127	4	101
● 75A-90HBFL	6	152	5	127
● 76A-90HBFL	7	178	6	152

Vertical Bend Barriers

- Vertical Bend Barriers are preformed to conform to a specific vertical fitting.
- Furnished with three #10 x 1/2" plated self-drilling screws and a 99-9982 Barrier Strip Splice.
- (*) Insert 30, 45, 60 or 90 for degrees
- (†) Insert 12, 24, 36 or 48 for radius

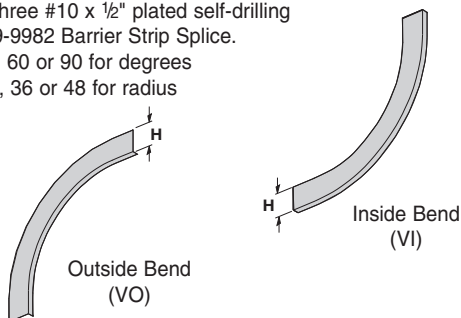

Inside Bend Catalog No.	Outside Bend Catalog No.	Side Rail Height		Loading Depth 'H'	
		in.	mm	in.	mm
● 73A-(*)VI(†)	● 73A-(*)VO(†)	4	101	3	76
● 74A-(*)VI(†)	● 74A-(*)VO(†)	5	127	4	101
● 75A-(*)VI(†)	● 75A-(*)VO(†)	6	152	5	127
● 76A-(*)VI(†)	● 76A-(*)VO(†)	7	178	6	152

Barrier Strip Clip

- Zinc plated steel barrier clip fastens to either aluminum or steel ladder rung.
- Furnished with one #10 x 1/2" zinc plated self-drilling screw.

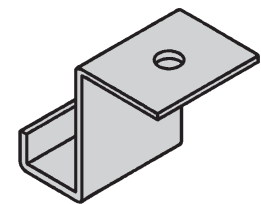
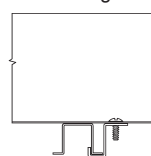

Catalog No. ● 9ZN-9002

Barrier Strip Splice

- Plastic splice holds adjoining barrier strips in straight alignment.

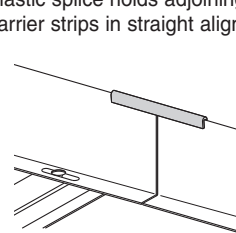

Catalog No. ● 99-9982

● Green = Fastest shipped items ● Black = Normal lead-time items ● Red = Normally long lead-time items

Series 2, 3, 4, & 5 Aluminum - Accessories

Stainless Steel Cable Clamp "P"

- Fits with series 2, 3, & 4 rungs.
- Attaches to rung at any point.
- 14 gauge Type 316 stainless steel material to minimize corrosion and induction heating.
- Plated steel and aluminum also available.

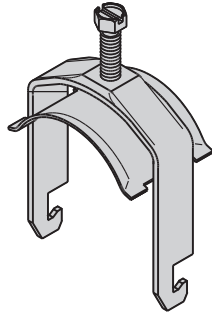

Refer to Section CF
Cable Fixing

Catalog No.	Cable Size	
	in.	mm
● BP081SS	.250 - .840	6.4 - 21.3
● BP110SS	.810 - 1.100	20.6 - 28.0
● BP135SS	.850 - 1.350	21.6 - 34.8
● BP175SS	1.250 - 1.750	31.8 - 44.5
● BP205SS	1.550 - 2.050	39.4 - 52.1
● BP250SS	2.000 - 2.500	50.8 - 63.5
● BP300SS	2.500 - 3.000	63.5 - 76.2
● BP325SS	2.750 - 3.250	69.9 - 82.6
● BP375SS	3.250 - 3.750	82.6 - 95.3
● BP425SS	3.750 - 4.250	95.3 - 108.0
● BP475SS	4.250 - 4.750	108.0 - 120.7

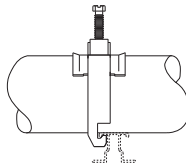
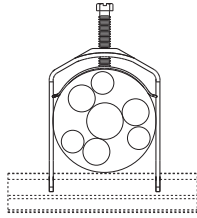

Bonding Jumper

Use at each expansion splice and where the cable tray is not mechanically/electrically continuous to ground.

- Sold individually.
- Hardware included.
- See table 392.7(B)(2) on page 25 for amperage ratings required to match the UL cross-sectional area of the tray.
- See tray loading chart for UL cross-sectional area.
- Bonding jumper is 16" long.

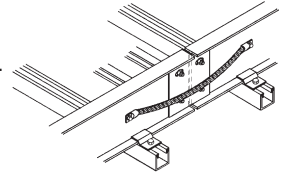

Catalog No.	Cross-Sectional Area	Ampacity
● 99-N1	0.40 Square inches	600
● 99-40	1.5 Square inches	1600
● 99-1620	2.0 Square inches	2000

Grounding Clamp

Cooper B-Line Cable Tray is UL® classified as to its suitability as an equipment grounding conductor. If a separate conductor for additional grounding capability is desired, Cooper B-Line offers this clamp for bolting the conductor at least once to each cable tray section.

- Accepts #6 AWG to 250 MCM.

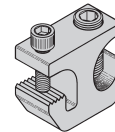

Catalog No.	Material
● 9A-2130	Tin Plated Aluminum

Ground Clamp

- Mechanically attaches grounding cables to cable tray.
- Hardware included.
- (*) Insert **ZN** or **SS4**

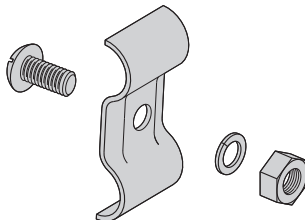

Catalog No.	Cable Size
9(*)-2351	#1 thru 2/0
9(*)-2352	3/0 thru 250 MCM

Hanger Rod Clamp

- For 1/2" ATR.
- Furnished in pairs.
- Order ATR and hex nuts separately.
- Two-piece "J"-hanger design.
- 1500 lbs./pair capacity safety factor 3.
- (*) Insert **ZN** or **G**

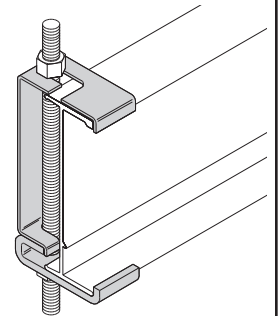

Catalog No.	Rail Height	
	in.	mm
9(*)-5324	4	101
9(*)-5325	5	127
9(*)-5326	6	152
9(*)-5327	7	178

Threaded Rod (ATR) & Rod Coupling

Size	Loading lbs	Catalog No.	Available Lengths	Coupling Cat. No.
3/8"-16	730	● ATR 3/8" x Length	36", 72", 120", 144"	● B655-3/8
1/2"-13	1350	● ATR 1/2" x Length	36", 72", 120", 144"	● B655-1/2

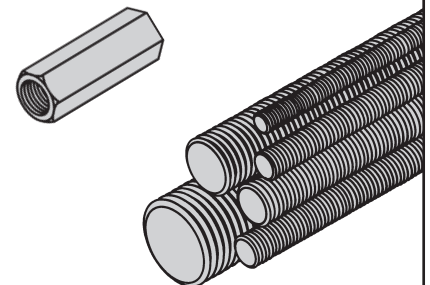

All dimensions in shaded areas are millimeters unless otherwise specified.

Loading based on safety factor 5.

Standard Finish: Zinc plated

See B-Line Strut Systems Catalog for other sizes and finishes.

● Green = Fastest shipped items ● Black = Normal lead-time items ● Red = Normally long lead-time items

Series 2, 3, 4, & 5 Aluminum - Accessories

Cable Tray Clamp/Guide

- Features a no-twist design.
- Has four times the strength of the traditional design.
- Each side is labeled to ensure proper installation.
- Furnished in pairs, with or without hardware.

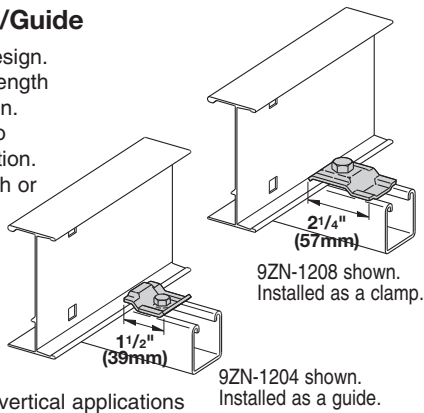

Patent #
RE35479

Note: For heavy duty or vertical applications see 9(*)-1241 or 9(*)-1242 page 245

Catalog No.		Overall Length		Hardware Size	Finish
Without Hardware	With Hardware	in.	mm		
● 9ZN-1204	● 9ZN-1204NB	1 1/2	38	1/4"	Znplt
● 9ZN-1208	● 9ZN-1208NB	2 1/4	57	3/8"	Znplt
● 9A-1205	--	2 1/4	57	1/2"	Alum.
● 9G-1205	--	2 1/4	57	1/2"	HDGAF
● 9SS6-1205	--	2 1/4	57	1/2"	316SS
● 9ZN-1205	--	2 1/4	57	1/2"	Znplt

Isolator Pad

- Use as a friction reducer and/or as a dissimilar metal isolator barrier.
- UV resistant HDPE.
- Temperature range: -100 to 160° F.
- Designed to use with 9(*)-1205 or 9(*)-1208 clamp/guide.

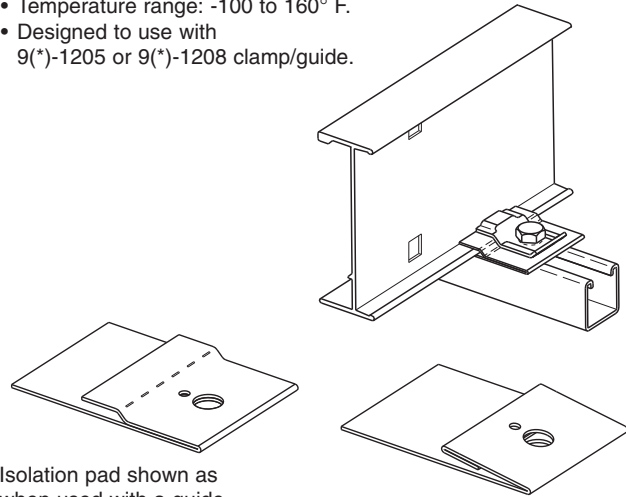

Isolation pad shown as when used with a guide.

Isolation pad shown with top flange doubled under for clamp application.

Catalog No. ● 99-PE34

Cable Tray Clamp

- Hold-down clamps for single or double cable tray runs.
- No drilling of support I-beam or channel is required.
- Sold in pieces
 - two clamps are required per tray.
- Maximum beam flange thickness 1 1/8" (28.58 mm).

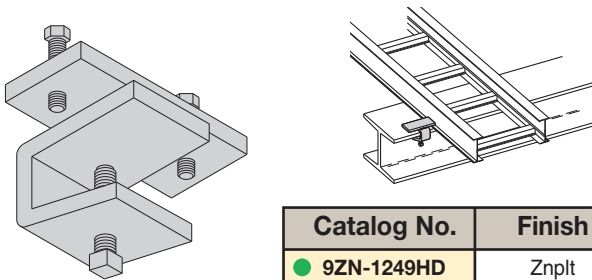

Catalog No.	Finish
● 9ZN-1249HD	Znplt
● 9G-1249HD	HDGAF

Cable Tray Guide

- Expansion guide for single or double cable tray runs.
- Guide allows for longitudinal movement of the cable tray.
- No field drilling of support I-beam or channel is required.
- Guides are required on both sides of cable tray to prevent lateral movement - can be placed on either the inside or outside flange of cable tray.
- Guides are sold in pieces - two guides are required per tray.
- Maximum flange thickness 1 1/8" (28.58 mm).

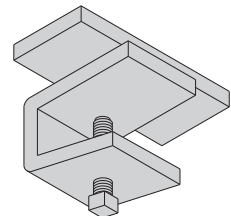

Catalog No.	Finish
● 9ZN-1249	Znplt
● 9G-1249	HDGAF

Nylon Pad

- Use for friction reduction.
- Hardness: Shore D80.
- Low friction coefficient.
- UV resistant.
- Excellent weatherability.
- UL - 94HB.

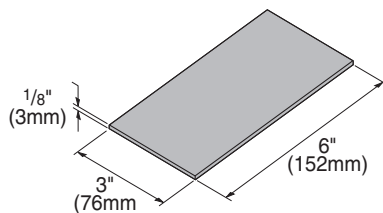

Catalog No. ● 99-NY36

Neoprene Roll

- Use for material isolation.
- 1/8" x 2" x 25' roll.
- Hardness: Shore A60.
- Good weatherability.

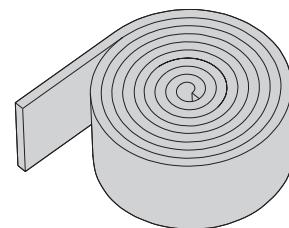

Catalog No. ● 99-NP300

● Green = Fastest shipped items ● Black = Normal lead-time items ● Red = Normally long lead-time items

Series 2, 3, 4, & 5 Aluminum - Accessories

Trapeze Support Kit

Cooper B-Line's trapeze kits provide the components required for a single trapeze support in one package. These kits are available in pre-galvanized steel with zinc-plated hardware or hot dip galvanized steel with 316 stainless steel hardware.

The SH channel provides the convenience of pre-punched slots, which eliminate the need for field drilling.

The illustrated hardware is sealed in a plastic bag and boxed with the channel, which is pre-cut to the appropriate length as shown in the chart.

Designed for use with 1/2" threaded rod. Order rod separately.

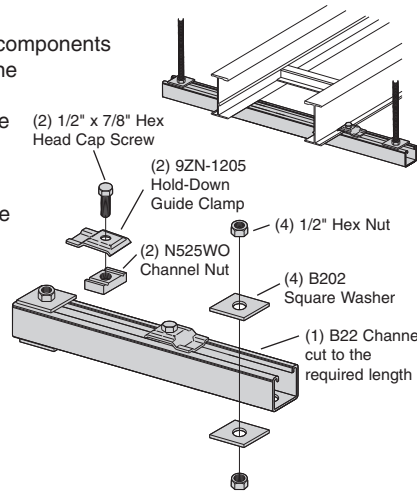

Catalog No.	Tray Width		Channel Length		Uniform Load	
	in.	mm	in.	mm	lbs	kN
● 9P-5506-22SH(†)	6	152	16	406	1600	7.11
● 9P-5509-22SH(†)	9	229	18	457	1250	5.56
● 9P-5512-22SH(†)	12	305	22	559	1125	5.00
● 9P-5518-22SH(†)	18	457	28	711	865	3.85
● 9P-5524-22SH(†)	24	610	34	864	700	3.11
● 9P-5530-22SH(†)	30	762	40	1016	590	2.62
● 9P-5536-22SH(†)	36	914	46	1168	510	2.27
● 9P-5542-22SH(†)	42	1067	52	1321	450	2.00

• (†) Insert 3/8 for 3/8" threaded rod hardware.

Safety factor of 3.0 on all loads.

Heavy Duty Trapeze Support Kit

Cooper B-Line's trapeze kits provide the components required for a single trapeze support in one package. These kits are available in Dura-Green® epoxy coated steel with zinc-plated hardware or hot dip galvanized steel with 316 stainless steel hardware.

The SH channel provides the convenience of pre-punched slots, which eliminates the need for field drilling.

The illustrated hardware is sealed in a plastic bag and boxed with the channel, which is pre-cut to the appropriate length as shown in the chart.

Designed for use with 1/2" threaded rod. Order rod separately.

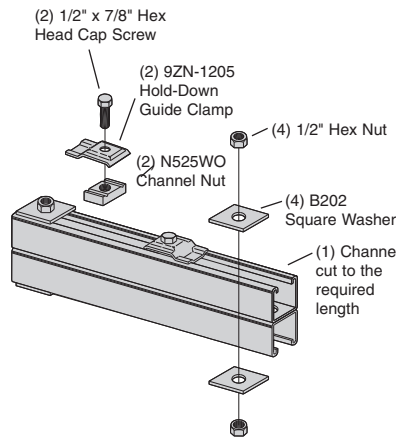

Catalog No.	Tray Width		Channel Length		Uniform Load	
	in.	mm	in.	mm	lbs	kN
9(*)-5506-22SHA	6	152	16	406	1350	6.01
9(*)-5509-22SHA	9	229	18	457	1350	6.01
9(*)-5512-22SHA	12	305	22	559	1350	6.01
9(*)-5518-22SHA	18	457	28	711	1350	6.01
9(*)-5524-22SHA	24	610	34	864	1350	6.01
9(*)-5530-22SHA	30	762	40	1016	1350	6.01
9(*)-5536-22SHA	36	914	46	1168	1350	6.01
9(*)-5542-22SHA	42	1067	52	1321	1350	6.01

• (*) Insert **GRN** or **G**

Safety factor of 3.0 on all loads.

Trapeze Hardware Kit

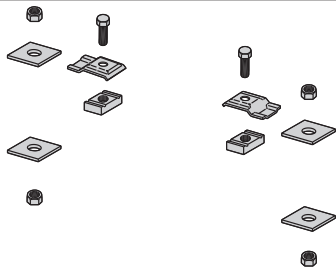

Catalog No.	● 9ZN-5500-1/2	● 9G-5500-1/2
In plastic bag	1 pr. 9ZN-1205 2 HHC Screw 1/2 x 7/8 ZN 2 N525 WO ZN 4 B202 ZN 1/2" sq washer 4 HN 1/2 ZN	1 pr. 9G-1205 2 HHC Screw 1/2 x 7/8 SS6 2 N525 WO SS6 4 B202 HDG 1/2" sq washer 4 HN 1/2 SS6

Rooftop Support Bases with B22 Channel

Designed as a superior rooftop support for cable tray,

UV resistant and approved for most roofing material or other flat surfaces.

Can be used with any of Cooper B-Line's cable tray clamps and guides.

Ultimate Load Capacity:
1,000 lbs. (uniform load)



Catalog No.	Height x Width x Length
● DB10-28	5 5/8" x 6" x 28.0"
● DB10-36	5 5/8" x 6" x 36.0"
● DB10-42	5 5/8" x 6" x 42.0"
● DB10-50	5 5/8" x 6" x 50.0"
● DB10-60	5 5/8" x 6" x 60.0"

♻️ LEEDS credit available, base made from 100% recycled material.

General Note: Consult roofing manufacturer or engineer for roof load capacity. The weakest point may be the insulation board beneath the rubber membrane.

● Green = Fastest shipped items ● Black = Normal lead-time items ● Red = Normally long lead-time items

Center Hung Tray Support

- Cooper B-Line's unique Center Hung Cable Tray Support allows cable to be laid-in from both sides.
- Eliminates costly cable pulling and field cutting of cable tray supports. Labor costs are dramatically reduced.
- Required hardware and threaded rod material for trapeze assemblies are reduced by 50%.
- Designed for use with 1/2" threaded rod. (Order rod separately)
- Use with all aluminum and steel cable trays through 24" width.
- Load capacity is 700 lbs. per support. Safety factor of 3.0. Eccentric loading is not to exceed a 60% vs. 40% load differential.
- The maximum recommended unsupported span length is 144"/12 ft. (3.66 m).
- Hardware shown is furnished.

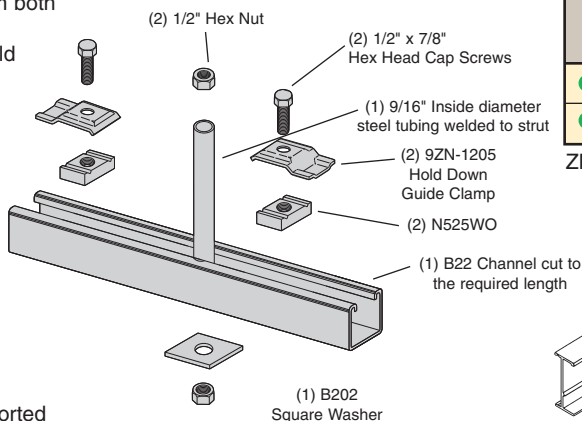

Catalog No.	Tray Width	Channel Length
● 9ZN-5212	6", 9", 12"	18"
● 9ZN-5224	18", 24"	30"

ZN = Zinc Plated

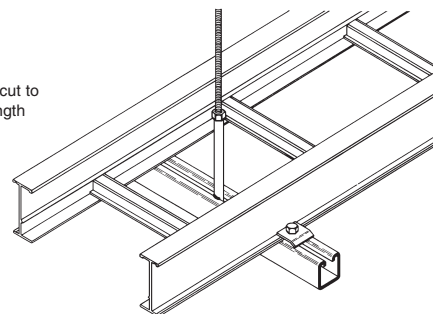

Center Hung Support Hardware Kit

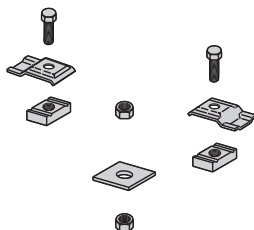

Catalog No.	● 9ZN-5200
In plastic bag	1 pr. 9ZN-1205 2 HHC Screw 1/2 x 7/8 ZN 2 N525 WO ZN 1 B202 ZN 1/2" sq washer 2 HN 1/2 ZN

Bracket

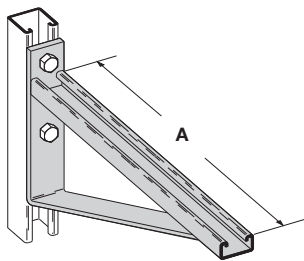

Finishes available: **ZN** **GRN** or **HDG**
Safety Load Factor 2.5

Catalog No.	Uniform Load		Tray Width		'A'	
	lbs	kN	in.	mm	in.	mm
B494-12	1580	7.02	6 & 9	152 & 229	12	305
B494-18	1000	4.45	12	305	18	457
B494-24	996	4.43	18	457	24	610

Bracket

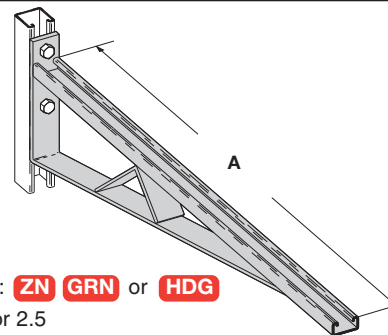

Finishes available: **ZN** **GRN** or **HDG**
Safety Load Factor 2.5

Catalog No.	Uniform Load		Tray Width		'A'	
	lbs	kN	in.	mm	in.	mm
B494-30	924	4.11	24	610	30	762
B494-36	864	3.84	30	762	36	914
B494-42	580	2.58	36	914	42	1067
B494-48	500	2.22	42	1067	48	1219

● Green = Fastest shipped items ● Black = Normal lead-time items ● Red = Normally long lead-time items

Series 2, 3, 4, & 5 Aluminum - Accessories

Cantilever Bracket

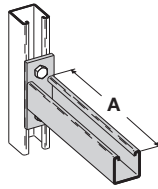

Finishes available: **ZN** **GRN** **HDG** **SS4** or **SS6**
Safety Load Factor 2.5

Catalog No.	Uniform Load		Tray Width		'A'	
	lbs	kN	in.	mm	in.	mm
B409-12	960	4.27	6 & 9	152 & 229	12	305
B409-18	640	2.84	12	305	18	457
B409-24	480	2.13	18	457	24	610

Cantilever Bracket

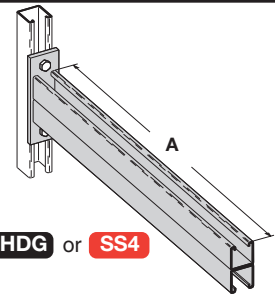

Finishes available: **ZN** **GRN** **HDG** or **SS4**
Safety Load Factor 2.5

Catalog No.	Uniform Load		Tray Width		'A'	
	lbs	kN	in.	mm	in.	mm
B297-12	1660	7.38	6 & 9	152 & 229	12	305
B297-18	1100	4.89	12	305	18	457
B297-24	835	3.71	18	457	24	610
B297-30	665	2.95	24	610	30	762
B297-36	550	2.44	30	762	36	914
B297-42	465	2.06	36	914	42	1067

Underfloor Support (U-Bolts not included)

U-Bolt Size	Fits Pipe O.D.
B501-3/4	.841 - 1.050
B501-1	1.051 - 1.315
B501-1 1/4	1.316 - 1.660
B501-1 1/2	1.661 - 1.900
B501-2	1.901 - 2.375
B501-2 1/2	2.376 - 2.875

• Order properly sized U-Bolts separately.

Finish available: **ZN**
Safety Load Factor 2.5

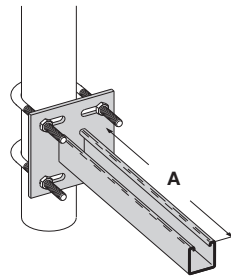

Catalog No.	Uniform Load		Tray Width		'A'	
	lbs	kN	in.	mm	in.	mm
B409UF-12	800	3.55	6 & 9	152 & 229	12	305
B409UF-21	450	2.00	12 & 18	305 & 457	21	533

Vertical Hanger Splice Plates

- Design load is 1500 lbs/pair. Safety Factor of 2.5
- Furnished in pairs with hardware.

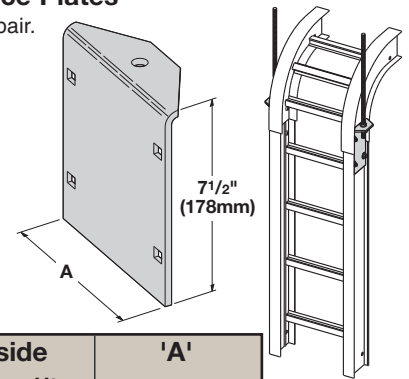

Catalog No.	Outside Cable Tray Ht.	'A'	
		in.	mm
● 9A-1224	4"	3.84	97.54
● 9A-1225	5"	4.73	120.14
● 9A-1226	6"	5.84	148.34
● 9A-1227	7"	6.84	173.74

Heavy Duty Hold Down Bracket

- Design load is 2000 lbs/pair.
- Two bolt design.
- Sold in pairs.
- 3/8" cable tray attachment hardware provided.
- 1/2" support attachment hardware **not** provided.
- (*) Insert **ZN** **SS4** or **SS6**

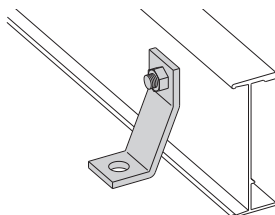

Catalog No.	9(*)-1241
-------------	-----------

Heavy Duty Hold-Down Bracket

- Design load is 4000 lbs/pair.
- Four bolt design.
- Sold in pairs.
- 3/8" cable tray attachment hardware provided
- 1/2" support attachment hardware **not** provided.
- (*) Insert **ZN** **SS4** or **SS6**

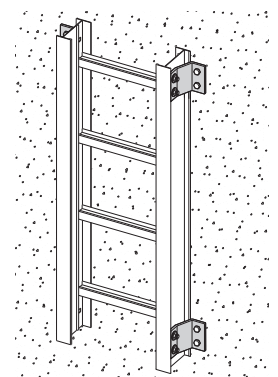
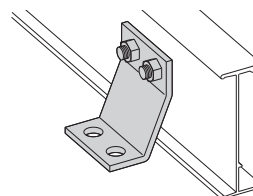

Catalog No.	9(*)-1242
-------------	-----------

● Green = Fastest shipped items ● Black = Normal lead-time items ● Red = Normally long lead-time items

Series 2, 3, 4, & 5 Aluminum

Series 2, 3, 4, & 5 Aluminum - Accessories

Beam Clamp

- Finishes available: **ZN** or **HDG**
- Sold in pieces.

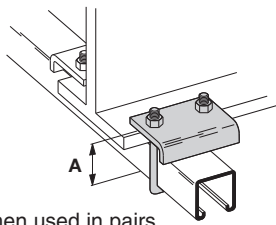

Design load when used in pairs.
Safety Load Factor 5.0

Catalog	Design Load*		'A'	
	lbs	kN	in.	mm
B441-22	1200	5.34	3 ³ / ₈	86
B441-22A	1200	5.34	5	127

Beam Clamp B355

- Finishes available: **ZN** **GRN** **HDG** or **SS4**
- Sold in pieces.
- Design load is 1200 lbs. when used in pairs.
- Safety Load Factor 5.0
- Order HHCS and Channel Nuts separately.

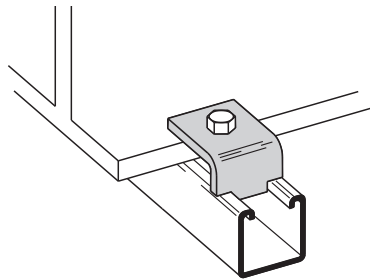

Beam Clamp

- Finishes available: **ZN** **GRN** or **HDG**
- Sold in pieces.

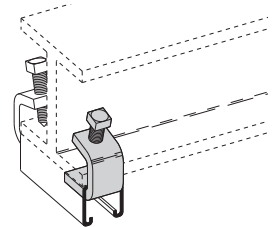

Design load when used in pairs.
Safety Load Factor 5.0

Cat. No.	B212-1/4		B212-3/8	
Design Load *	600 lbs.	2.67 kN	1000 lbs.	4.45 kN
Max. Flange Thick	3/4"	19 mm	1 1/8"	28.6 mm
Mat'l. Thickness	1/4"	6.3 mm	3/8"	9.5 mm

B305 Thru B308 & B321 Series Beam Clamps

- Finishes available: **ZN** or **HDG**
- Setscrew included.
- Safety Load Factor 5.0

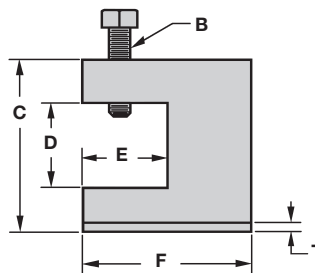
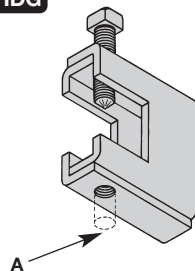

Cat. No.	Rod Size A	B	C	D	E	F	T	Design Load	
								lbs	kN
B305	3/8"-16	3/8"-16	2 5/16"	7/8"	1 1/8"	2 1/2"	11 Ga.	600	2.67
B306	3/8"-16	1/2"-13	2 7/16"	7/8"	1 1/8"	2 1/2"	7 Ga.	1100	4.90
B307	1/2"-13	1/2"-13	2 7/16"	7/8"	1 1/8"	2 1/2"	7 Ga.	1100	4.90
B308	1/2"-13	1/2"-13	2 9/16"	7/8"	1 1/8"	2 1/2"	1/4"	1500	6.68
B321-1	3/8"-16	1/2"-13	3 9/16"	1 11/16"	1 5/8"	3 1/4"	1/4"	1300	5.79
B321-2	1/2"-13	1/2"-13	3 9/16"	1 11/16"	1 5/8"	3 1/4"	1/4"	1400	6.23

B312 Anchor Strap

- Finish available: **ZN**
- For a maximum beam thickness of 3/4".
- For thicker beams, step up one flange width size.

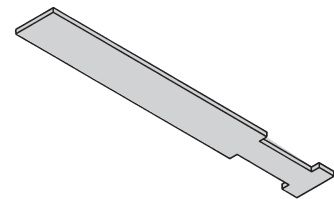

Cat. No.	Flange Width
B312-6	Up to 6"
B312-9	6" - 9"
B312-12	9" - 12"

Beam Clamp

Catalog No.	For Flange Width		Wt./C	
	in.	mm	lbs	kg
B750-J4	3" - 6"	76.2 - 152.4	109	49.4
B750-J6	5" - 9"	127.0 - 228.6	124	56.2
B750-J9	8" - 12"	203.2 - 304.8	135	61.2
B750-J12	11" - 15"	279.4 - 381.0	147	66.7

- Finish available: **ZN**
- Design Load 500 lbs. (2.22 kN)
- Safety Load Factor 5.0
- Recommended torque: 'J'-Hook Nut 125 In.-Lbs. (14.1 kN/m)
- Maximum flange thickness of 3/4"

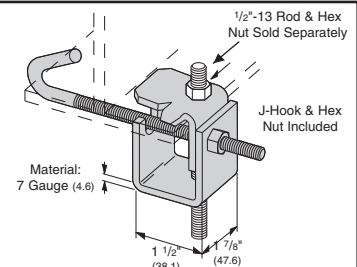

Beam Clamp

Catalog No.	'A'		Thread Length 'TL'		Wt./C	
	in.	mm	in.	mm	lbs	kg
B700-J4	8 1/2"	215.9	5"	127.0	44	19.9
B700-J6	11 1/2"	292.1	6"	152.4	53	24.0
B700-J9	12 1/4"	368.3	6"	152.4	63	28.6
B700-J12	17 1/2"	444.5	6"	152.4	78	35.4

- Finish available: **ZN**
- Hex Nut included.

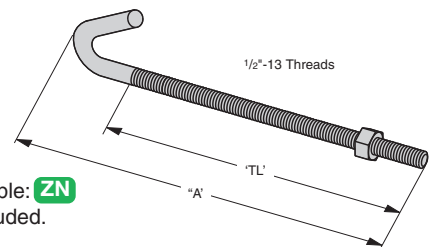

● Green = Fastest shipped items ● Black = Normal lead-time items ● Red = Normally long lead-time items