

## B591 SERIES PIPE BRACKET SADDLE AND CLAMP

- Safety Factor of 3
- Inside brace not required on B591-2 and B591-2 1/2
- Includes:
  - 1 pc. Saddle bottom
  - 1 pc. Saddle top (clamp)
  - 2 pcs. Hex Head Cap Screws
  - 2 pcs. Hex Nuts
- Standard finish: ZN

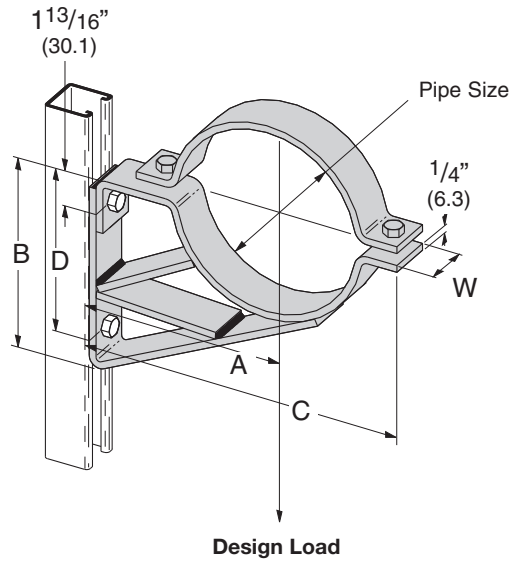

Part No.	Pipe Size		A		B		C		D		W		Design Load		Wt./C	
	in	(mm)	in	(mm)	in	(mm)	in	(mm)	in	(mm)	in	(mm)	Lbs.	kN	Lbs.	kg
<b>B591-2</b>	2"	(50)	4 1/2"	(114.3)	4 1/2"	(114.3)	7 3/16"	(182.6)	3 1/16"	(77.8)	1 5/8"	(41.3)	1235	(5.53)	290	(131.5)
<b>B591-2 1/2</b>	2 1/2"	(65)	5"	(127.0)	5"	(127.0)	7 15/16"	(201.6)	3 9/16"	(90.5)	1 5/8"	(41.3)	1180	(5.29)	330	(149.7)
<b>B591-3</b>	3"	(80)	5 1/2"	(139.7)	5 3/4"	(146.0)	8 3/4"	(222.2)	3 13/16"	(96.8)	1 5/8"	(41.3)	1125	(5.04)	439	(199.1)
<b>B591-3 1/2</b>	3 1/2"	(90)	6"	(152.4)	6 3/4"	(171.4)	9 1/2"	(241.3)	4 9/16"	(115.9)	1 5/8"	(41.3)	1070	(4.79)	490	(222.2)
<b>B591-4</b>	4"	(100)	6 1/2"	(165.1)	6 3/4"	(171.4)	10 1/4"	(260.3)	6 1/16"	(128.6)	1 5/8"	(41.3)	1015	(4.55)	545	(247.2)
<b>B591-5</b>	5"	(125)	7 1/2"	(190.5)	8"	(203.2)	12 1/8"	(308.0)	6 1/16"	(154.0)	1 5/8"	(41.3)	960	(4.30)	666	(302.1)
<b>B591-6</b>	6"	(150)	8"	(203.2)	8 3/4"	(222.2)	13 3/16"	(335.0)	6 13/16"	(173.0)	1 5/8"	(41.3)	905	(4.05)	724	(328.4)
<b>B591-8</b>	8"	(200)	9"	(228.6)	10 1/2"	(266.7)	15 9/16"	(395.3)	8 9/16"	(217.5)	2"	(50.8)	850	(3.81)	1087	(493.0)

Reference page 126 for general fitting and standard finish specifications.