

# B72 Channel

- Thickness: 18 Ga. (1.2 mm)
- Standard lengths: 10' (3.05 m)
- Standard finishes: Plain, Dura-Green, Pre-Galvanized
- Weight: .29 Lbs./Ft. (.43 kg/m)

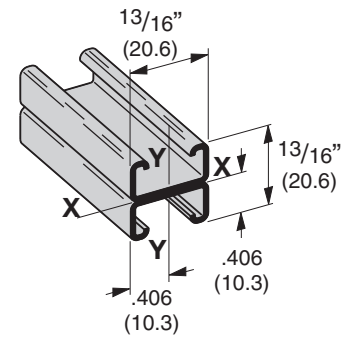
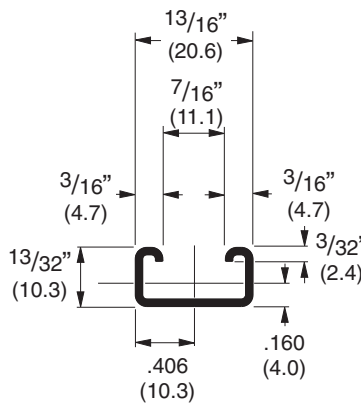
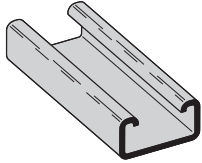

**B72A**  
Wt. .58 Lbs./Ft. (.87 kg/m)

## SECTION PROPERTIES

Channel	Weight		Areas of Section		Moment of Inertia (I)		Section Modulus (S)		Radius of Gyration (r)		Moment of Inertia (I)		Section Modulus (S)		Radius of Gyration (r)	
	lbs./ft.	kg/m	sq. in.	cm <sup>2</sup>	in. <sup>4</sup>	cm <sup>4</sup>	in. <sup>3</sup>	cm <sup>3</sup>	in.	cm	in. <sup>4</sup>	cm <sup>4</sup>	in. <sup>3</sup>	cm <sup>3</sup>	in.	cm
<b>B72</b>	.287	(.43)	.084	(.54)	.0018	(.07)	.0073	(.12)	.146	(.37)	.0077	(.32)	.0190	(.31)	.302	(.77)
<b>B72A</b>	.574	(.85)	.169	(1.09)	.0078	(.32)	.0192	(.31)	.215	(.55)	.0155	(.65)	.0382	(.63)	.303	(.77)

Calculations of section properties are based on metal thicknesses as determined by the AISI Cold-Formed Steel Design Manual.

## BEAM LOADING

Beam Span		Channel Style	Uniform Load and Deflection				Uniform Load @ Deflection =			
In.	mm		Lbs.	N	In.	mm	1/240 Span		1/360 Span	
						Lbs.	N	Lbs.	N	
12	(305)	<b>B72</b> <b>B72A</b>	116 210*	(516.0) (934.1)	.051 .020	(1.29) (.51)	113 210*	(502.6) (934.1)	75 210*	(324.7) (934.1)
24	(609)	<b>B72</b> <b>B72A</b>	58 159	(258.0) (707.2)	.206 .125	(5.23) (3.17)	28 127	(124.5) (564.9)	19 85	(84.5) (378.1)
36	(914)	<b>B72</b> <b>B72A</b>	39 106	(173.5) (471.5)	.465 .281	(11.81) (7.14)	13 57	(57.8) (253.5)	8 38	(35.6) (169.0)
36	(1219)	<b>B72</b> <b>B72A</b>	29 80	(129.0) (355.8)	.827 .500	(21.00) (12.70)	7 32	(31.1) (142.3)	5 21	(22.2) (93.4)
60	(1524)	<b>B72</b> <b>B72A</b>	23 64	(102.3) (284.7)	1.292 .782	(32.81) (19.86)	5 20	(22.2) (88.9)	3 14	(13.3) (62.3)

Based on simple beam condition using an allowable design stress of 25,000 psi (172 MPa) in accordance with MFMA, with adequate lateral bracing (see page 11 for further explanation). Actual yield point of cold rolled steel is 42,000 psi. To determine concentrated load capacity at mid span, multiply uniform load by 0.5 and corresponding deflection by 0.8. \*Failure determined by weld shear.

## COLUMN LOADING

Unbraced Height		Channel Style	Max. Column Loading K = .80				Max. Column Loading (Loaded @ C.G.)					
In.	mm		Loaded @ C.G.		Loaded @ Slot Face		K = .65		K = 1.0		K = 1.2	
		Lbs.	N	Lbs.	N	Lbs.	N	Lbs.	N	Lbs.	N	
12	(305)	<b>B72</b> <b>B72A</b>	1598 3600	(7108) (16013)	539 986	(2397) (4386)	1712 3700	(7615) (16458)	1410 3433	(6272) (15271)	1181 3229	(5253) (14363)
24	(609)	<b>B72</b> <b>B72A</b>	701 2710	(3118) (12054)	320 802	(1423) (3567)	1050 3113	(4670) (13847)	450 2043	(2001) (9088)	313** 1421	(1392) (6321)
36	(914)	<b>B72</b> <b>B72A</b>	313** 1421	(1392) (6321)	188 569	(836) (2531)	473 2135	(2104) (9497)	201** 909	(894) (4043)	— 631**	— (2807)
36	(1219)	<b>B72</b> <b>B72A</b>	177** 799	(787) (3554)	122 404	(542) (1797)	267** 1211	(1187) (5387)	— 512**	— (2277)	— 355**	— (1579)
60	(1524)	<b>B72</b> <b>B72A</b>	113** 512**	(502) (2277)	85 298	(378) (1325)	171** 775	(760) (3447)	— 327**	— (1454)	— —	— —

\*\*Where the slenderness ratio  $\frac{KL}{r}$  exceeds 200, and K = end fixity factor, L = actual length and r = radius of gyration.

Reference page 200 for general fitting specifications.