

**B526**  
TWO HOLE  
OFFSET Z-SUPPORT

- Standard finishes: ZN, GRN
- Wt./C 38 Lbs. (17.2 kg)

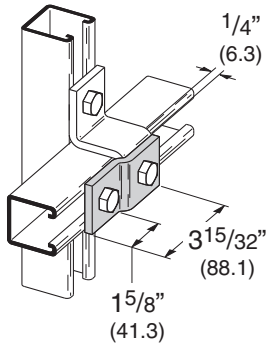

**B106-52**  
TWO HOLE  
Z-SUPPORT FOR B52

- Standard finishes: ZN, GRN
- Wt./C 40 Lbs. (18.1 kg)

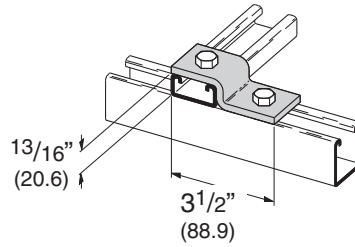

**B106-42**  
TWO HOLE  
Z-SUPPORT FOR B42

- Standard finishes: ZN, GRN
- Wt./C 44 Lbs. (20.0 kg)

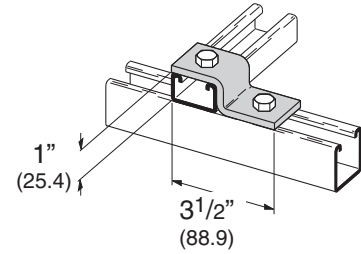

**B106-32**  
TWO HOLE  
Z-SUPPORT FOR B32

- Standard finishes: ZN, GRN
- Wt./C 51 Lbs. (23.1 kg)

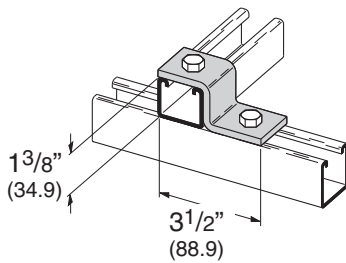

**B106-12**  
TWO HOLE  
Z-SUPPORT FOR B12

- Standard finishes: ZN, GRN
- Wt./C 63 Lbs. (28.6 kg)

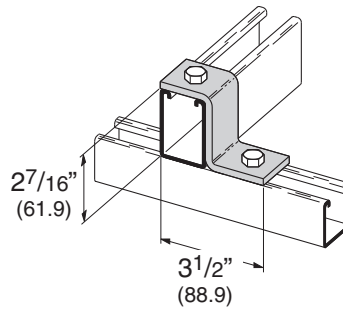

**B105**  
THREE HOLE  
Z-SUPPORT FOR B22

- Standard finishes: ZN, GRN, HDG
- Wt./C 51 Lbs. (23.1 kg)

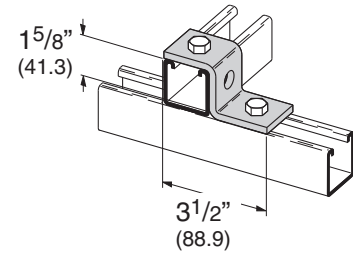

**B110**  
THREE HOLE  
Z-SUPPORT FOR B11

- Standard finishes: ZN, GRN
- Wt./C 70 Lbs. (31.7 kg)

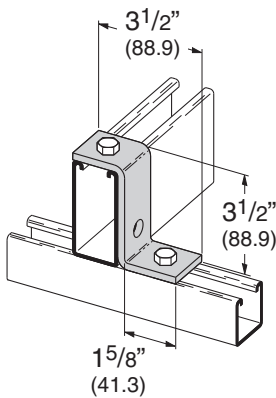

**B586**  
TWO HOLE  
Z-SUPPORT

- Standard finishes: ZN, GRN
- Wt./C 90 Lbs. (40.8 kg)

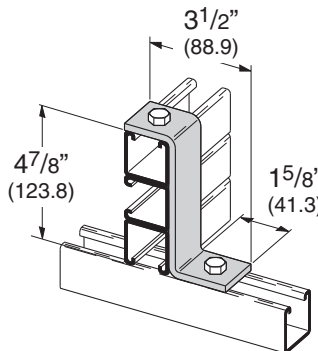

**B108**  
TWO HOLE  
OFFSET Z-SUPPORT

- Standard finishes: ZN, GRN
- Wt./C 55 Lbs. (24.9 kg)

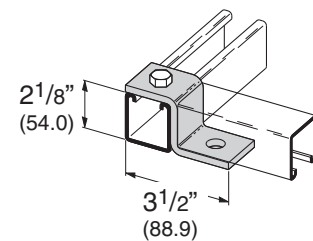

Reference page 72 for general fitting and standard finish specifications.

# 'Z' Fittings

## B387 TWO HOLE Z-BUS DUCT CONNECTION

- Standard finishes: ZN, GRN

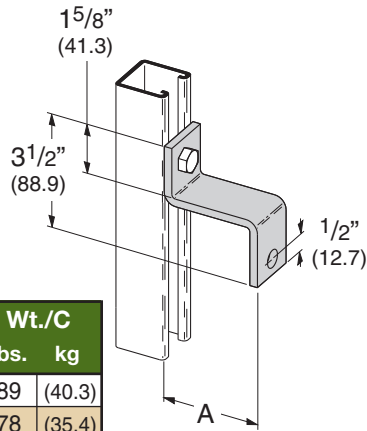

Part No.	A	(A)	Wt./C	
			Lbs.	kg
B387	4 <sup>3</sup> / <sub>4</sub> "	(120.6)	89	(40.3)
B387-1	3 <sup>25</sup> / <sub>32</sub> "	(96.0)	78	(35.4)
B387-2	2 <sup>13</sup> / <sub>32</sub> "	(61.1)	62	(28.1)

## B407 TWO HOLE Z-SUPPORT

- Standard finishes: ZN, GRN

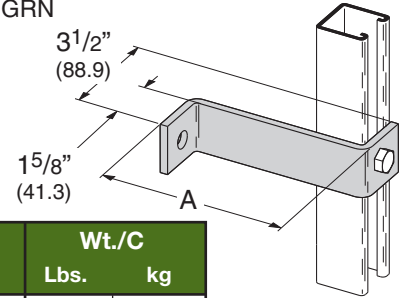

Part No.	A	(A)	Wt./C	
			Lbs.	kg
B407-4	4"	(101.6)	77	(34.9)
B407-5	5"	(127.0)	95	(43.1)
B407-6	6"	(152.4)	98	(44.4)
B407-7	7"	(177.8)	105	(47.6)
B407-8	8"	(203.2)	120	(54.4)
B407-9 <sup>5</sup> / <sub>8</sub>	9 <sup>5</sup> / <sub>8</sub> "	(244.5)	138	(62.6)

## B534 TAPPED Z-SUPPORT

- Standard finishes: ZN
- Wt./C 51 Lbs. (23.1 kg)

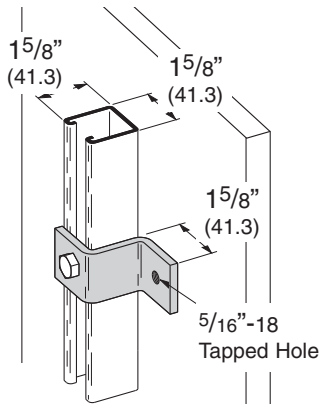

## B535 TAPPED Z-SUPPORT

- Standard finishes: ZN
- Wt./C 50 Lbs. (22.7 kg)

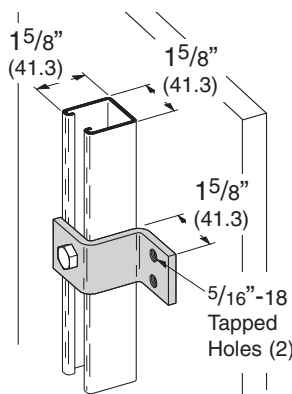

## B111 THREE HOLE SHEATH CORNER CONNECTION

- Standard finishes: ZN, GRN
- Wt./C 68 Lbs. (30.8 kg)

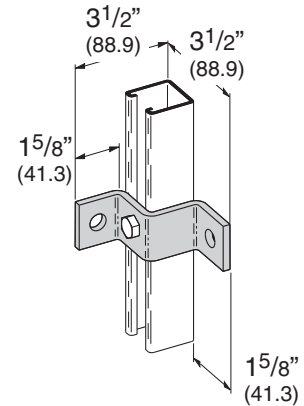

## B538 TAPPED CORNER CONNECTION

- Standard finishes: ZN
- Wt./C 71 Lbs. (32.2 kg)

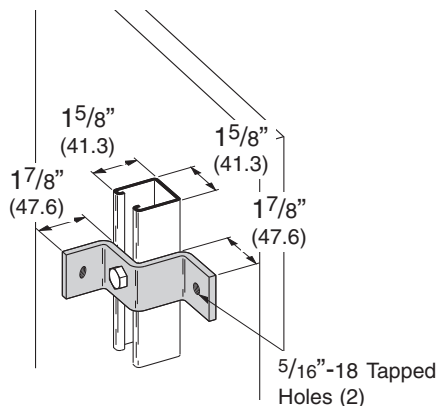

## B539 TAPPED CORNER CONNECTION

- Standard finishes: ZN
- Wt./C 68 Lbs. (30.8 kg)

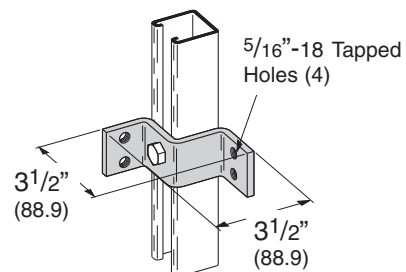

Reference page 72 for general fitting and standard finish specifications.

## B410-52 CHANNEL HANGER BRACKET FOR B52

- Material: 11 Gauge (3.0)  
ASTM A1011 HSLAS Gr. 50
- Standard finishes: ZN, GRN
- Wt./C 6.7 Lbs. (3.0 kg)

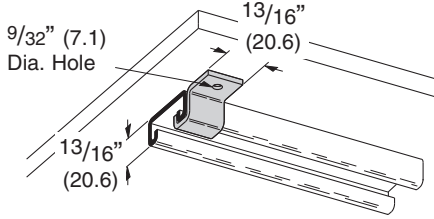

## B410-32 CHANNEL HANGER BRACKET FOR B32

- Material: 11 Gauge (3.0)  
ASTM A1011 HSLAS Gr. 50
- Standard finishes: ZN, GRN
- Wt./C 8.3 Lbs. (3.7 kg)

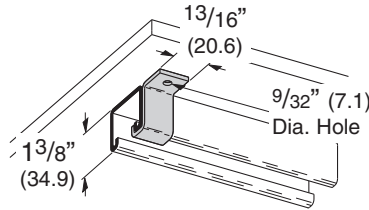

## B410-22 CHANNEL HANGER BRACKET FOR B22

- Material: 11 Gauge (3.0)  
ASTM A1011 HSLAS Gr. 50
- Standard finishes: ZN, GRN
- Wt./C 9 Lbs. (4.1 kg)

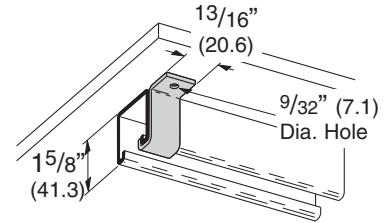

## B410-12 CHANNEL HANGER BRACKET FOR B12

- Material: 11 Gauge (3.0)  
ASTM A1011 HSLAS Gr. 50
- Standard finishes: ZN, GRN
- Wt./C 11.2 Lbs. (5.1 kg)

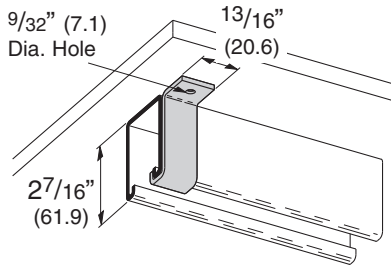

## B410-11 CHANNEL HANGER BRACKET FOR B11

- Material: 11 Gauge (3.0)  
ASTM A1011 HSLAS Gr. 50
- Standard finishes: ZN, GRN
- Wt./C 13.4 Lbs. (6.1 kg)

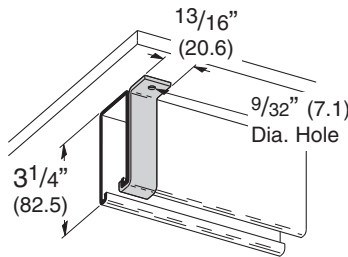

## B580 FIVE HOLE GUSSETED Z-SUPPORT

- Standard finishes: ZN, GRN
- Wt./C 100 Lbs. (45.3 kg)

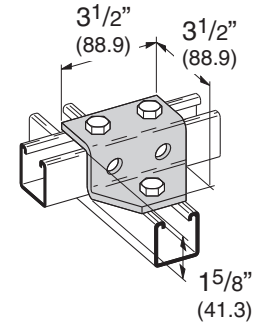

## B515 ADJUSTABLE OFFSET GUSSETED Z-SUPPORT

- Standard finishes: ZN, GRN
- Wt./C 93 Lbs. (42.2 kg)

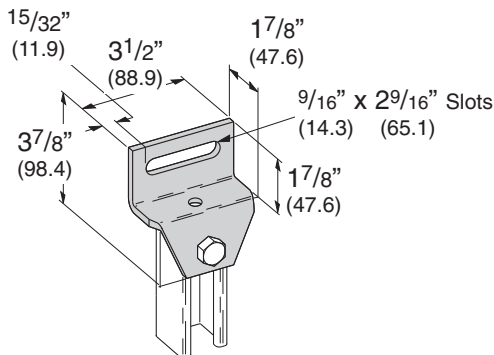

## B428 EIGHT HOLE GUSSETED CORNER CONNECTION

- Standard finishes: ZN, GRN
- Wt./C 203 Lbs. (92.1 kg)

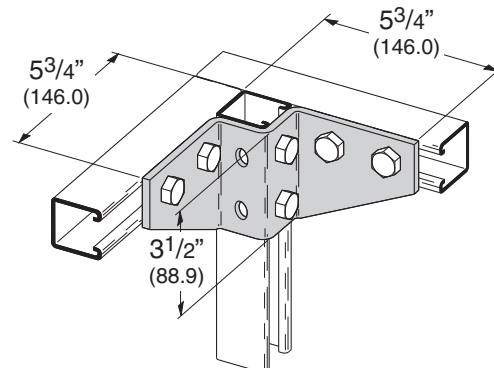

Reference page 72 for general fitting and standard finish specifications.