

Clevis Fittings

B169 TWO HOLE SPLICE CLEVIS FOR B52

- Standard finishes: ZN, GRN
- Wt./C 84 Lbs. (38.1 kg)

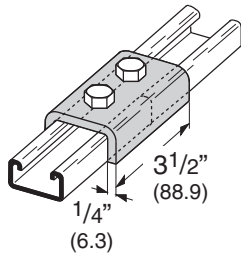

B168 THREE HOLE SPLICE CLEVIS FOR B52

- Standard finishes: ZN, GRN
- Wt./C 126 Lbs. (57.1 kg)

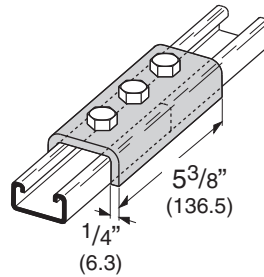

B167 FOUR HOLE SPLICE CLEVIS FOR B52

- Standard finishes: ZN, GRN
- Wt./C 178 Lbs. (80.7 kg)

PA GRN

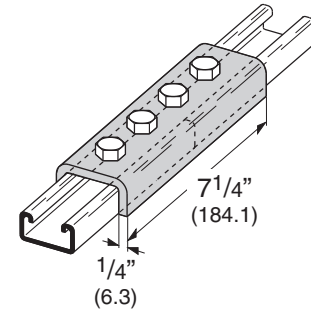

B170 TWO HOLE SPLICE CLEVIS FOR B22 OR B52A

- Standard finishes: ZN, GRN
- Wt./C 123 Lbs. (55.8 kg)

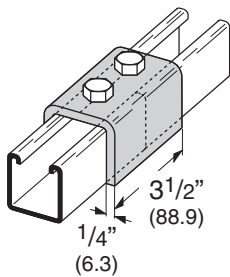

B171 THREE HOLE SPLICE CLEVIS FOR B22 OR B52A

- Standard finishes: ZN, GRN
- Wt./C 195 Lbs. (88.4 kg)

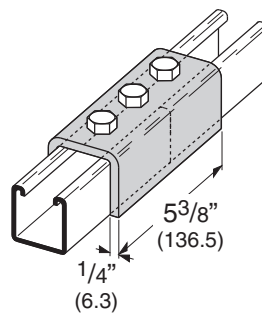

B172 FOUR HOLE SPLICE CLEVIS FOR B22 OR B52A

- Standard finishes: ZN, GRN
- Wt./C 266 Lbs. (120.6 kg)

PA ZN GRN

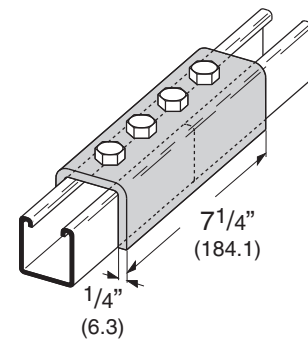

B172-12 FOUR HOLE SPLICE CLEVIS FOR B12

- Standard finishes: ZN, GRN
- Wt./C 326 Lbs. (147.8 kg)

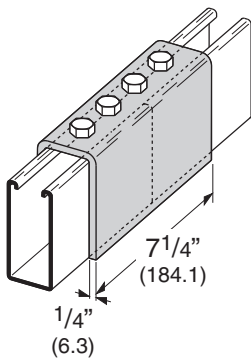

B172-22A FOUR HOLE SPLICE CLEVIS FOR B11 OR B22A

- Standard finishes: ZN, GRN
- Wt./C 406 Lbs. (184.1 kg)

PA GRN

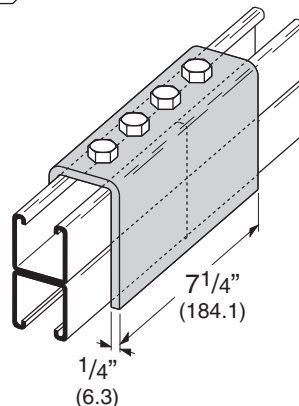

B450 U-WASHER

- Material: ASTM A1011 HSLAS Gr. 50
- Standard finishes: ZN, GRN

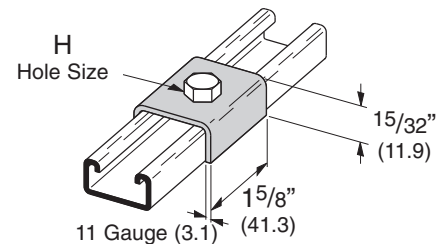

Part No. & Size	Hole Size H	Wt./C Lbs. kg
B450-1/4	5/16" (7.9)	14 (6.3)
B450-3/8	7/16" (11.1)	14 (6.3)
B450-1/2	9/16" (14.3)	13 (5.8)
B450-5/8	11/16" (17.4)	13 (5.8)
B450-3/4	13/16" (20.6)	13 (5.8)