

## B187 BRACKET

- Uniform Loading 1450 Lbs. (6.45 kN)
- Safety Factor of 2.5
- Hole Spacing on Bracket Top  $5\frac{5}{16}$ " (150.8) Center to Center
- Standard finishes: ZN, GRN
- Wt./C 193 Lbs. (87.5 kg)

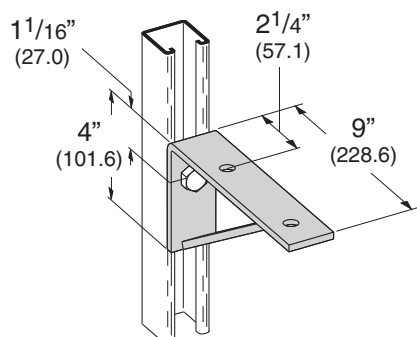

## B188 BRACKET

- Uniform Loading 1080 Lbs. (4.80 kN)
- Safety Factor of 2.5
- Hole Spacing on Bracket Top  $8\frac{15}{16}$ " (227.0) Center to Center
- Standard finishes: ZN, GRN
- Wt./C 241 Lbs. (109.3 kg)

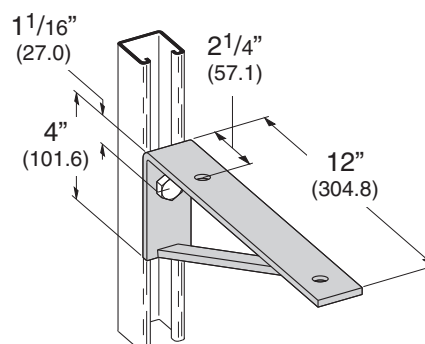

## B189 BRACKET

- Uniform Loading 870 Lbs. (3.87 kN)
- Safety Factor of 2.5
- Hole Spacing on Bracket Top  $11\frac{15}{16}$ " (303.2) Center to Center
- Standard finishes: ZN, GRN
- Wt./C 308 Lbs. (139.7 kg)

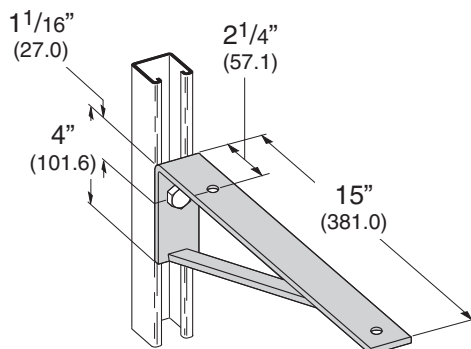

## B541 BRACKET

- Uniform Loading 1240 Lbs. (5.51 kN)
- Safety Factor of 2.5
- Hole Spacing on Bracket Top  $7\frac{7}{16}$ " (188.9) Center to Center
- Standard finishes: ZN, GRN
- Wt./C 201 Lbs. (91.2 kg)

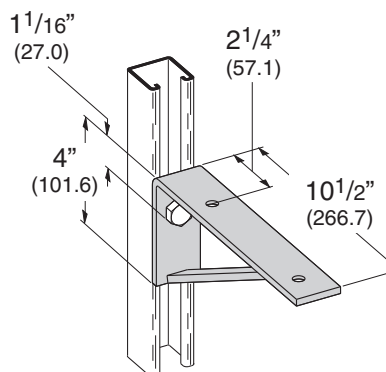

## B190 12" (304.8) BRACKET

- Uniform Loading 900 Lbs. (4.00 kN)
- Safety Factor of 2.5
- Standard finishes: ZN, GRN
- Wt./C 260 Lbs. (117.9 kg)

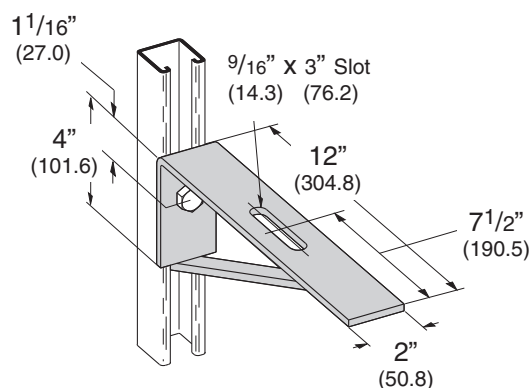

## B191-18 18" (457.2) BRACKET

- Uniform Loading 600 Lbs. (2.67 kN)
- Safety Factor of 2.5
- Standard finishes: ZN, GRN
- Wt./C 377 Lbs. (171.0 kg)

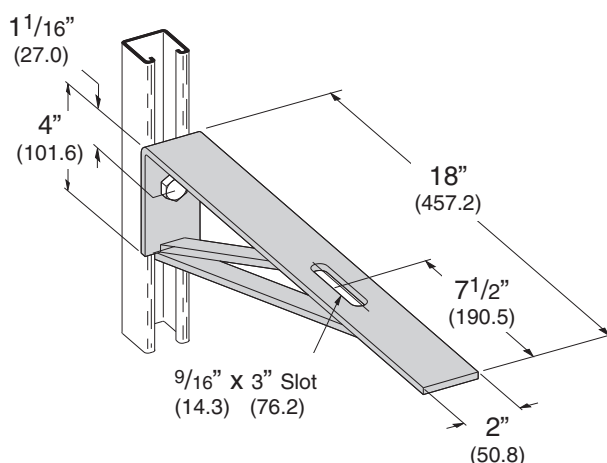

Reference page 72 for general fitting and standard finish specifications.

# Brackets

## B191-24 24" (609.6) BRACKET

- Uniform Loading 450 Lbs. (2.00 kN)
- Safety Factor of 2.5
- Standard finishes: ZN, GRN
- Wt./C 377 Lbs. (171.0 kg)

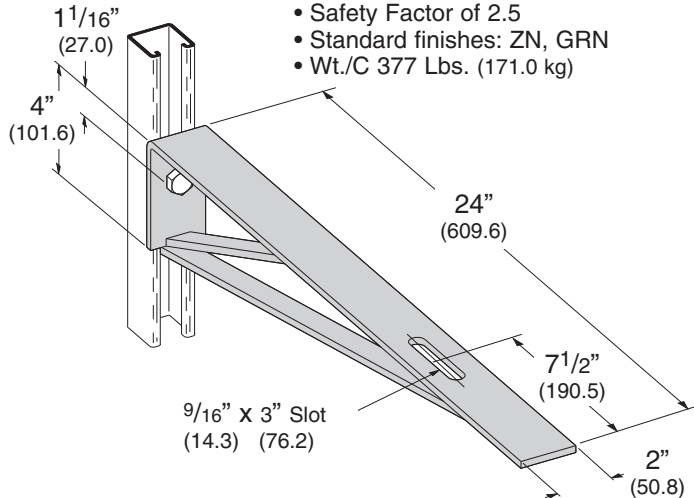

## B192 24" (609.6) BRACKET

- Uniform Loading 820 Lbs. (3.65 kN)
- Safety Factor of 2.5
- Standard finishes: ZN, GRN
- Wt./C 576 Lbs. (261.3 kg)

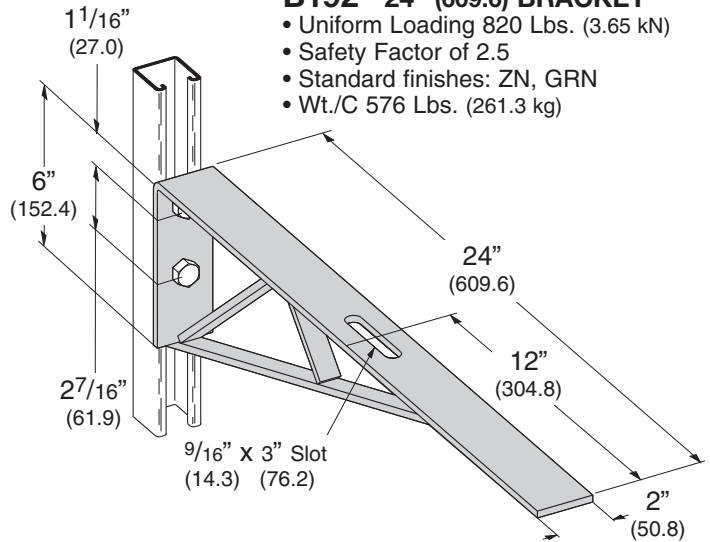

## B290 16 1/2" (419.1) BRACKET

- Uniform Loading 1200 Lbs. (5.34 kN)
- Safety Factor of 2.5
- Standard finishes: ZN, GRN
- Wt./C 405 Lbs. (183.7 kg)

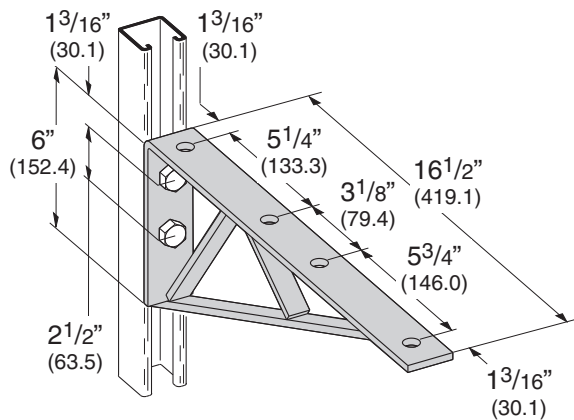

## B289-12 12 1/2" (317.5) BRACKET

- Uniform Loading 1040 Lbs. (4.63 kN)
- Safety Factor of 2.5
- Standard finishes: ZN, GRN
- Wt./C 285 Lbs. (129.3 kg)

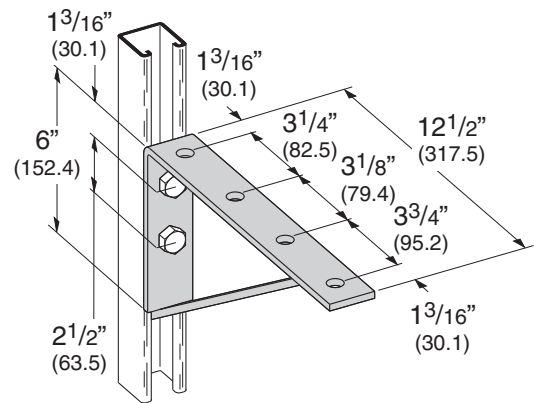

## B289-14 14 1/2" (368.3) BRACKET

- Uniform Loading 900 Lbs. (4.00 kN)
- Safety Factor of 2.5
- Standard finishes: ZN, GRN
- Wt./C 295 Lbs. (133.8 kg)

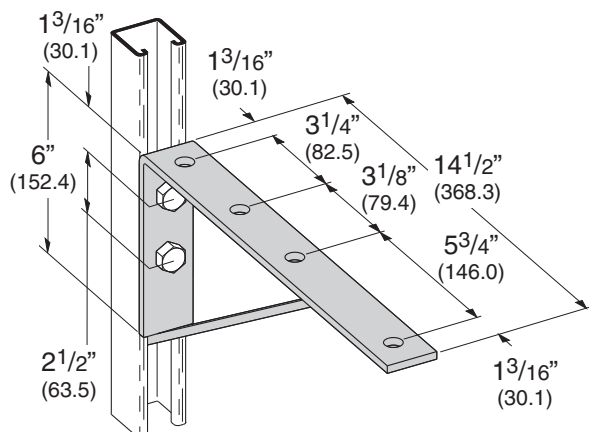

## B291 18 1/2" (469.9) BRACKET

- Uniform Loading 1070 Lbs. (4.76 kN)
- Safety Factor of 2.5
- Standard finishes: ZN, GRN
- Wt./C 468 Lbs. (212.3 kg)

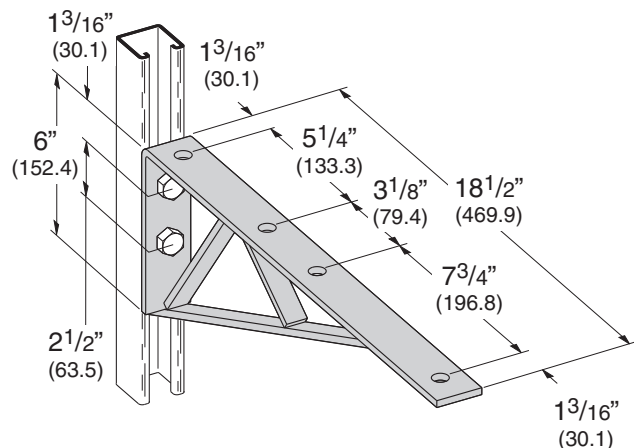

Reference page 72 for general fitting and standard finish specifications.

## B292 20<sup>1</sup>/<sub>2</sub>" (520.7) BRACKET

- Uniform Loading 600 Lbs. (2.67 kN)
- Safety Factor of 2.5
- Standard finishes: ZN, GRN, HDG, SS4
- Wt./C 490 Lbs. (222.2 kg)

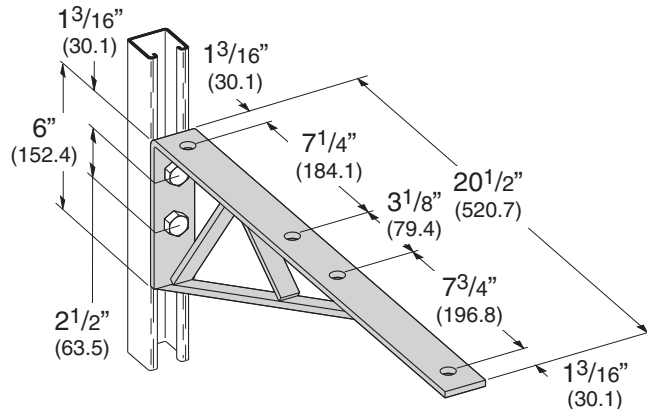

## B297 DOUBLE CHANNEL BRACKET

- Safety Factor of 2.5
- Standard finishes: ZN, GRN, HDG

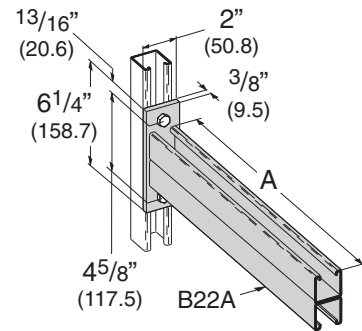

Part No.	A	Uniform Load		Wt./C	
		Lbs.	kN	Lbs.	kg
B297-12	12" (304.8)	1660	(7.37)	485	(220.0)
B297-18	18" (457.2)	1100	(4.88)	668	(303.0)
B297-24	24" (609.6)	835	(3.71)	857	(388.7)
B297-30	30" (762.0)	665	(2.95)	1040	(471.7)
B297-36	36" (914.4)	550	(2.44)	1240	(562.4)
B297-42	42" (1066.8)	465	(2.06)	1440	(653.2)

## B409 SINGLE CHANNEL BRACKET

- Safety Factor of 2.5
- Standard finishes: ZN, GRN, SS4

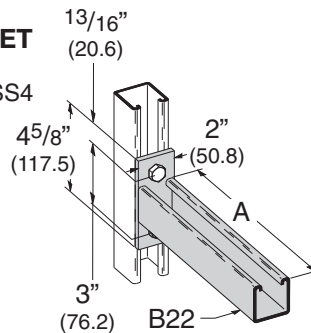

Part No.	A	Uniform Load		Wt./C	
		Lbs.	kN	Lbs.	kg
B409-6	6" (152.4)	1920	(8.54)	152	(68.9)
B409-9	9" (228.6)	1280	(5.69)	195	(88.4)
B409-12	12" (304.8)	960	(4.27)	232	(105.2)
B409-14	14" (355.6)	800	(3.56)	274	(124.3)
B409-16	16" (406.4)	730	(3.25)	314	(142.4)
B409-18	18" (457.2)	640	(2.84)	347	(157.4)
B409-24	24" (609.6)	480	(2.13)	450	(204.1)

## B494 BRACED SINGLE BRACKET

- Safety Factor of 2.5
- Standard finishes: ZN, GRN

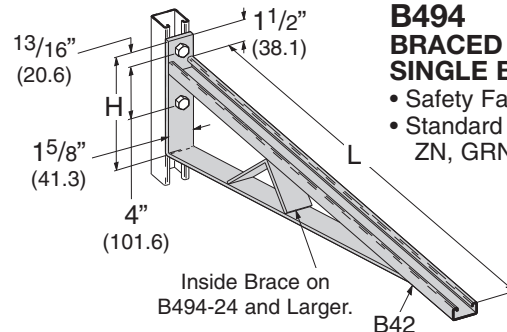

Part No.	L	H	Uniform Load		Wt. /C	
			Lbs.	kN	Lbs.	kg
B494-12	12" (304.8)	8 <sup>3</sup> / <sub>4</sub> " (222.2)	1580	(7.02)	364	(165.1)
B494-18	18" (475.2)	8 <sup>3</sup> / <sub>4</sub> " (222.2)	1000	(4.45)	479	(217.3)
B494-24	24" (609.6)	8 <sup>3</sup> / <sub>4</sub> " (222.2)	996	(4.43)	716	(324.8)
B494-30	30" (762.0)	11 <sup>1</sup> / <sub>4</sub> " (285.7)	924	(4.11)	927	(420.5)
B494-36	36" (914.4)	11 <sup>1</sup> / <sub>4</sub> " (285.7)	864	(3.84)	1095	(496.7)
B494-42	42" (1066.8)	16" (406.4)	580	(2.58)	1400	(635.0)
B494-48	48" (1219.2)	16" (406.4)	500	(2.22)	1510	(684.9)

## B174SH-B186SH L&R SLOTTED BRACKET

- Safety Factor of 2.5
- Specify L for left or R for right bracing
- Material: ASTM A1011 33,000 PSI min. yield
- Standard finishes: ZN, GRN

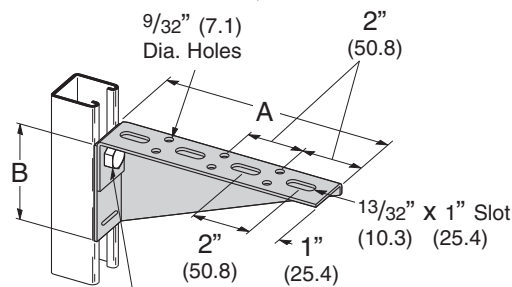

Mounting Hole  
7/16" (11.1) Dia.

Right bracket shown, left bracket  
gusset on opposite side.

Part No.	A	B	Uniform Load		Wt./C	
			Lbs.	kN	Lbs.	kg
B174SH	24" (609.6)	6 <sup>7</sup> / <sub>16</sub> " (163.5)	225	(1.00)	370	(167.8)
B175SH	26" (660.4)	6 <sup>15</sup> / <sub>16</sub> " (176.2)	225	(1.00)	425	(192.8)
B176SH	28" (711.2)	7 <sup>7</sup> / <sub>16</sub> " (188.9)	225	(1.00)	480	(217.7)
B177SH	30" (762.0)	7 <sup>15</sup> / <sub>16</sub> " (201.6)	225	(1.00)	520	(235.9)
B178SH	12" (304.8)	3 <sup>7</sup> / <sub>16</sub> " (87.3)	350	(1.55)	143	(64.8)
B179SH	14" (355.6)	3 <sup>15</sup> / <sub>16</sub> " (100.0)	350	(1.55)	162	(73.5)
B180SH	16" (406.4)	4 <sup>7</sup> / <sub>16</sub> " (112.7)	250	(1.11)	204	(92.5)
B181SH	18" (457.2)	4 <sup>15</sup> / <sub>16</sub> " (125.4)	250	(1.11)	232	(105.2)
B182SH	20" (508.0)	5 <sup>7</sup> / <sub>16</sub> " (138.1)	250	(1.11)	275	(124.7)
B183SH	22" (558.8)	5 <sup>15</sup> / <sub>16</sub> " (150.8)	250	(1.11)	317	(143.8)
B184SH	6" (152.4)	1 <sup>15</sup> / <sub>16</sub> " (49.2)	225	(1.00)	58	(26.3)
B185SH	8" (203.2)	2 <sup>7</sup> / <sub>16</sub> " (61.9)	225	(1.00)	82	(37.2)
B186SH	10" (254.0)	2 <sup>15</sup> / <sub>16</sub> " (74.6)	325	(1.44)	103	(46.7)

Reference page 72 for general fitting and standard finish specifications.

# Brackets

## B196 CHANNEL CLEVIS BRACKET

- Safety Factor of 2.5
- Standard finishes: ZN, GRN

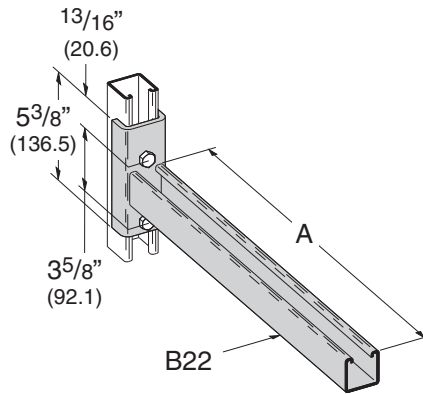

Part No.	A	(A)	Uniform Load		Wt./C	
			Lbs.	kN	Lbs.	kg
B196-18	18"	(457.2)	600	(2.67)	430	(195.0)
B196-24	24"	(609.6)	450	(2.00)	510	(231.3)

## B198A CHANNEL CLEVIS BRACKET

- Safety Factor of 2.5
- Standard finishes: ZN, GRN

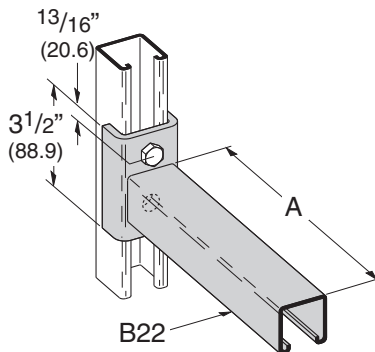

Part No.	A	(A)	Uniform Load		Wt./C	
			Lbs.	kN	Lbs.	kg
B198A-6	6"	(152.4)	1600	(7.12)	185	(83.9)
B198A-12	12"	(304.8)	800	(3.56)	284	(128.8)

## B293A CHANNEL BRACKET

- Safety Factor of 2.5
- Standard finishes: ZN, GRN

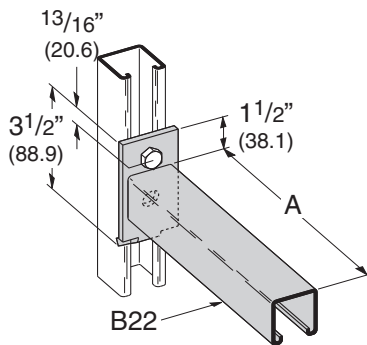

Part No.	A	(A)	Uniform Load		Wt./C	
			Lbs.	kN	Lbs.	kg
B293A-6	6"	(152.4)	1200	(5.34)	144	(65.3)
B293A-12	12"	(304.8)	600	(2.67)	252	(114.3)
B293A-18	18"	(457.2)	400	(1.78)	340	(154.2)
B293A-24	24"	(609.6)	300	(1.33)	412	(186.9)

## B198 CHANNEL CLEVIS BRACKET

- Safety Factor of 2.5
- Standard finishes: ZN, GRN

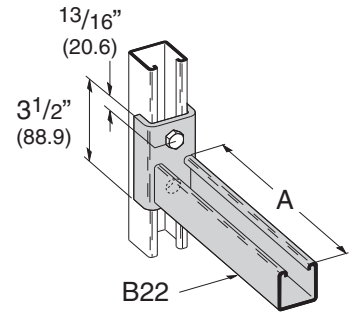

Part No.	A	(A)	Uniform Load		Wt./C	
			Lbs.	kN	Lbs.	kg
B198-6	6"	(152.4)	1600	(7.12)	185	(83.9)
B198-12	12"	(304.8)	800	(3.56)	284	(128.8)

## B293 CHANNEL BRACKET

- Safety Factor of 2.5
- Standard finishes: ZN, GRN

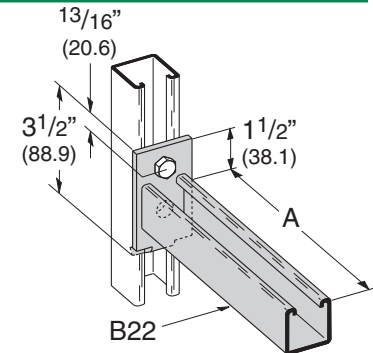

Part No.	A	(A)	Uniform Load		Wt./C	
			Lbs.	kN	Lbs.	kg
B293-6	6"	(152.4)	1200	(5.34)	144	(65.3)
B293-12	12"	(304.8)	600	(2.67)	252	(114.3)
B293-18	18"	(457.2)	400	(1.78)	340	(154.2)
B293-24	24"	(609.6)	300	(1.33)	412	(186.9)

## B194 BRACKET FOR B22 & B24

- Safety Factor of 2.5
- 6300 In.-Lbs (712 N\*m) applies to fitting only, not to strength of strut arm
- Refer to page 223 for strut loading data
- Standard finishes: ZN, GRN
- Wt./C 210 Lbs. (95.2 kg)

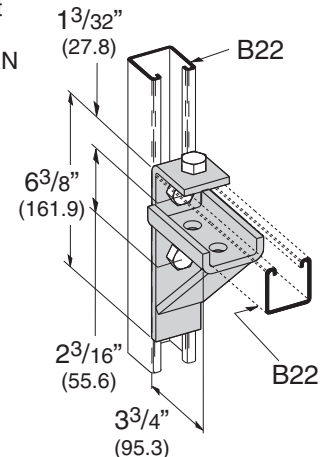

Reference page 72 for general fitting and standard finish specifications.

## B370 BRACKET FOR B22A & B11

- Safety Factor of 2.5
- 13000 In.-Lbs (1469 N•m) applies to fitting only, not to strength of strut arm
- Refer to page 217 for strut loading data
- Standard finishes: ZN, GRN
- Wt./C 266 Lbs. (120.6 kg)

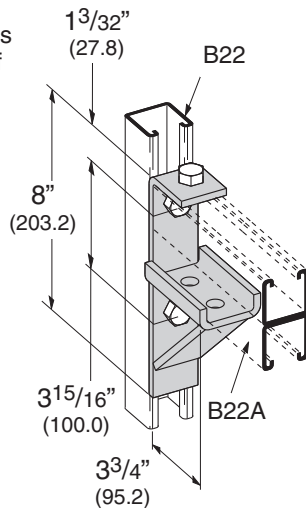

## B195 BRACKET FOR B42

- Safety Factor of 2.5
- 2500 In.-Lbs (282 N•m) applies to fitting only, not to strength of strut arm
- Refer to page 217 for strut loading data
- Standard finishes: ZN, GRN
- Wt./C 174 Lbs. (78.9 kg)

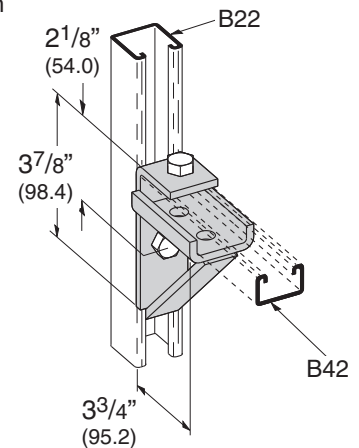

## B440 BRACKET FOR B52 & B54

- Safety Factor of 2.5
- 2000 In.-Lbs (226 N•m) applies to fitting only, not to strength of strut arm
- Refer to page 217 for strut loading data
- Standard finishes: ZN, GRN
- Wt./C 177 Lbs. (80.3 kg)

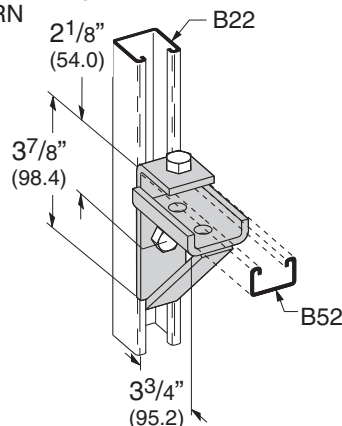

## B449-4, 8 & 12 CABLE SADDLE BRACKET

- Safety Factor of 2.5
- Material: 11 Gauge (3.0) ASTM A1011 HSLAS Gr. 50
- Standard finishes: ZN, GRN

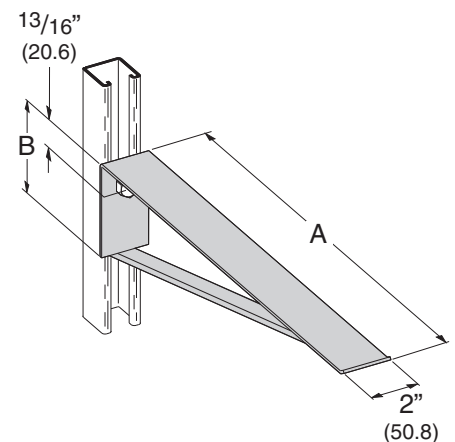

Part No.	A	B	Uniform Load		Wt./C	
			Lbs.	kN	Lbs.	kg
B449-4	4 1/2" (114.3)	2 3/8" (60.3)	2400	(10.67)	74	(33.5)
B449-8	8 1/2" (215.9)	2 3/8" (60.3)	1270	(5.65)	124	(56.2)
B449-12	12 1/2" (317.5)	4" (101.6)	860	(3.82)	184	(83.4)

## B449-18 18" (457.2) CABLE SADDLE BRACKET

- Safety Factor of 2.5
- Uniform Load 960 Lbs. (4.17 kN)
- Material: 11 Gauge (3.0) ASTM A1011 HSLAS Gr. 50
- Standard finishes: ZN, GRN
- Wt./C 312 Lbs. (141.5 kg)

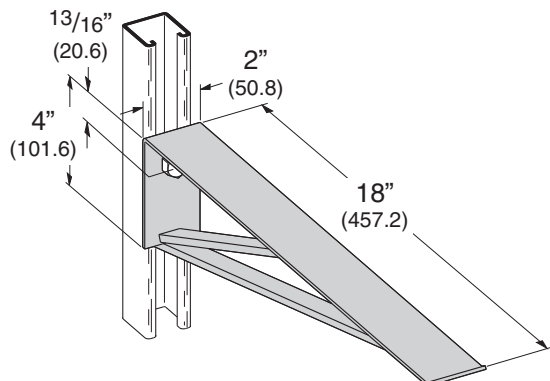

## B293PL BRACKET PLATE ONLY

- Standard finishes: ZN, GRN
- Wt./C 46 Lbs. (20.8 kg)

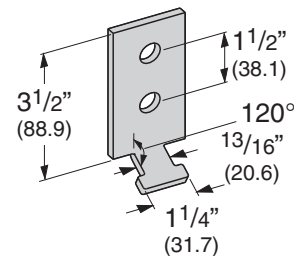

Reference page 72 for general fitting and standard finish specifications.

# Brackets

## B816

- Standard finishes: ZN, HDG

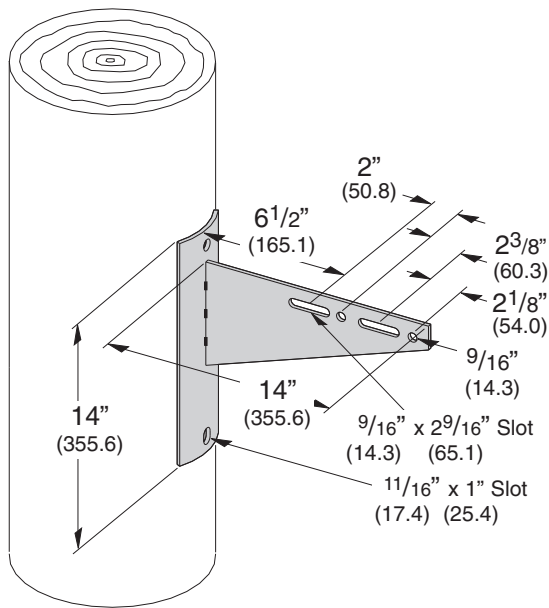

## B852S-W-D

- Specify W = 8, 12, 16
- Specify D = 6, 8, 10, 12, 16, 18, 24
- 13/16" (20.6mm) x 1" (25.4mm) banding slots for steel band
- Standard finishes: ZN, HDG

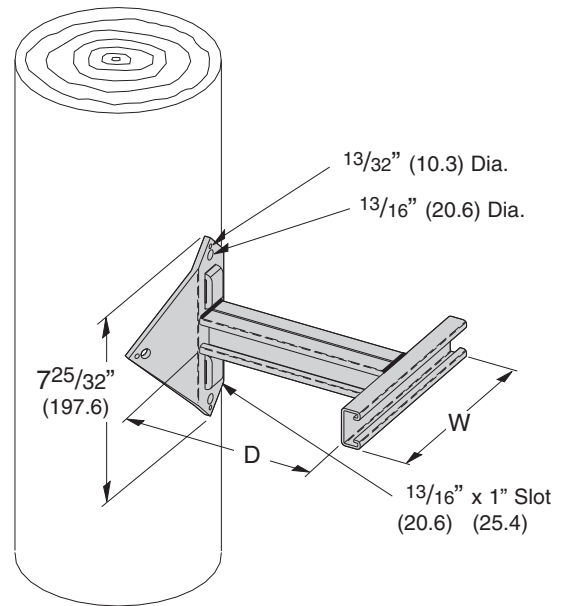

## B802D-W

- Specify W = 8, 12, 16
- Standard finishes: ZN, HDG

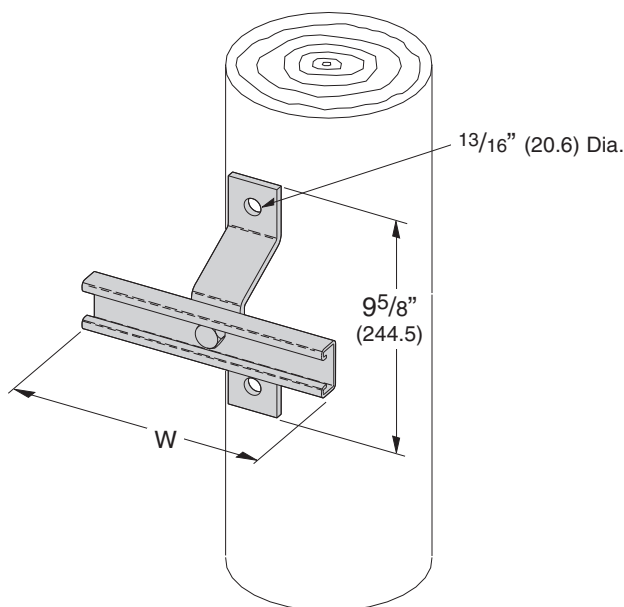

## B810-W

- Specify W = 8, 12, 16
- 13/16" (20.6mm) x 1" (25.6mm) banding slots for steel band
- Standard finishes: ZN, HDG

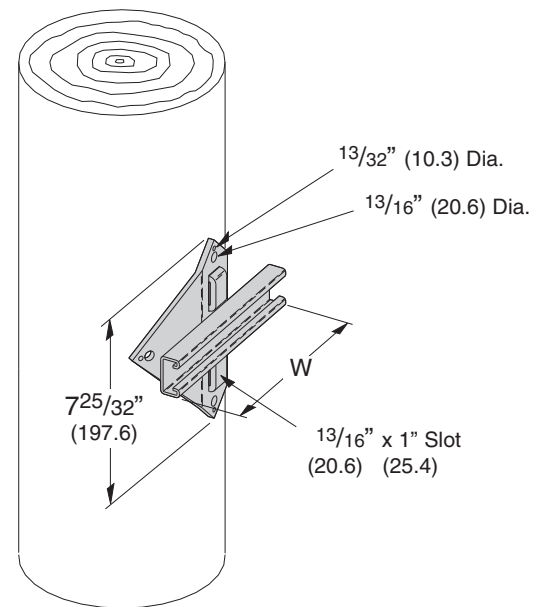

Reference page 72 for general fitting and standard finish specifications.

## B811-W

- Can be attached directly to B809 & B812
- Specify W = 8, 12, 16
- Standard finishes: ZN, HDG

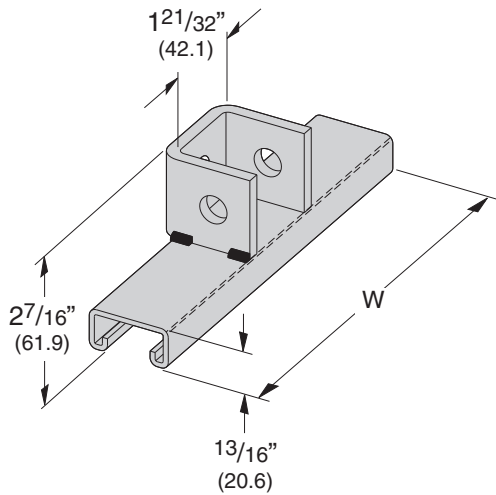

## B812-\*

- Specify D = 6, 8, 10, 12, 16, 18, 24
- 13/16" (20.6mm) x 1" (25.4mm) banding slots for steel band
- Standard finishes: ZN, HDG

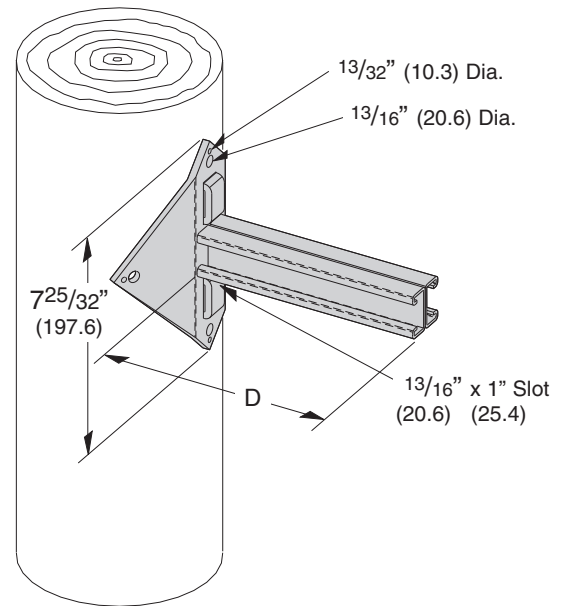

## B809B-\*

- Specify D = 6, 8, 10, 12, 16, 18, 24
- 13/16" (20.6mm) x 1" (25.4mm) banding slots for steel band
- Standard finishes: ZN, HDG

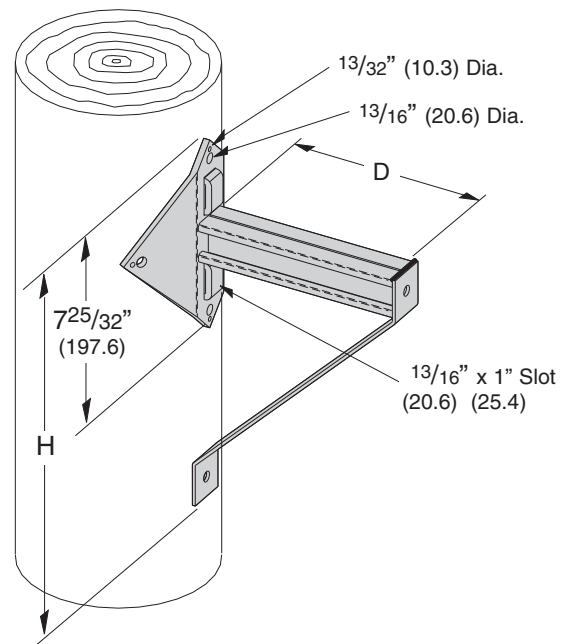

Part No.	D		H	
	In.	mm	In.	mm
B809B-6	6"	(152.4)	12 <sup>3</sup> / <sub>4</sub> "	(323.9)
B809B-8	8"	(203.2)	14 <sup>3</sup> / <sub>4</sub> "	(374.7)
B809B-10	10"	(254.0)	16 <sup>3</sup> / <sub>4</sub> "	(425.5)
B809B-12	12"	(304.8)	18 <sup>3</sup> / <sub>4</sub> "	(476.2)
B809B-16	16"	(406.4)	22 <sup>3</sup> / <sub>4</sub> "	(577.8)
B809B-18	18"	(457.2)	24 <sup>3</sup> / <sub>4</sub> "	(628.6)
B809B-24	24"	(609.6)	27 <sup>3</sup> / <sub>4</sub> "	(704.8)

Reference page 72 for general fitting and standard finish specifications.