

Fiberglass

BF*22I CONCRETE INSERTS

- Design Load 300 Lbs (1.47 kN)
- Safety Factor of 3
- Standard lengths: 6" (152), 12" (305), 24" (609), 36" (914), 48" (1219), 60" (1524), 72" (1829), 84" (2133), 96" (2438), 108" (2743) and 120" (3048)
- Available Material:
 - *Insert P for BFP - Polyester Resin channel and tee
 - *Insert V for BFV - Vinyl Ester Resin channel with Polyester Resin tee
- Shipped with removable styrofoam insert

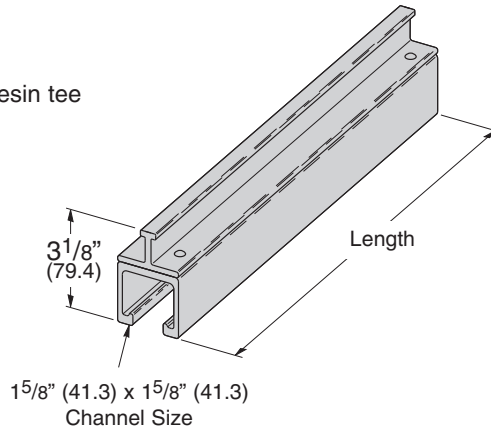

Field Cutting Sealant Kits

RSK010 ... Pint Sealing Kit (473 cm³)
includes sealant and brush applicator

- Seals exposed fibers after field cutting. •
- UV resistant •

BFV501 SERIES U-BOLTS WITH HEX NUTS

- Design Load Safety Factor of 3
- Load A: Straight down loading
- Load B: Side loading
- Inner surface of U-Bolt is flat to provide additional contact surface area
- Material: Glass Reinforced Polyurethane

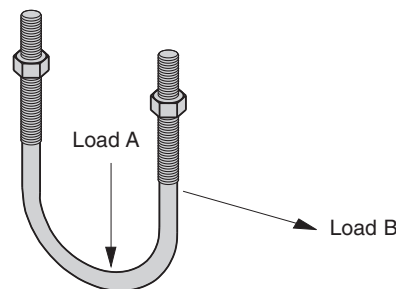

Part No.	Nominal Pipe Size		Thread Size	Design Load A		Design Load B		Maximum Torque		Wt./C	
	in.	mm		Lbs.	kN	Lbs.	kN	in.-Lbs.	N•m	Lbs.	kg
BFV501-1/2	1/2	(15)	3/8"-16	300	(1.33)	150	(.67)	30	(3.4)	3.5	(1.59)
BFV501-3/4	3/4	(20)	3/8"-16	300	(1.33)	150	(.67)	30	(3.4)	3.9	(1.77)
BFV501-1	1	(25)	3/8"-16	300	(1.33)	150	(.67)	30	(3.4)	4.4	(1.99)
BFV501-1 1/4	1 1/4	(32)	3/8"-16	300	(1.33)	150	(.67)	30	(3.4)	4.8	(2.18)
BFV501-1 1/2	1 1/2	(40)	3/8"-16	300	(1.33)	150	(.67)	30	(3.4)	5.2	(2.36)
BFV501-2	2	(50)	1/2"-13	600	(2.67)	200	(.89)	60	(6.8)	7.7	(3.49)
BFV501-2 1/2	2 1/2	(65)	1/2"-13	600	(2.67)	200	(.89)	60	(6.8)	10.2	(4.63)
BFV501-3	3	(80)	1/2"-13	600	(2.67)	200	(.89)	60	(6.8)	12.6	(5.71)
BFV501-3 1/2	3 1/2	(90)	1/2"-13	600	(2.67)	200	(.89)	60	(6.8)	15.1	(6.85)
BFV501-4	4	(100)	1/2"-13	600	(2.67)	200	(.89)	60	(6.8)	17.6	(7.98)

Reference page 182 for general fitting specifications.