

B718

UNIVERSAL JUNCTION BOX

- Assemble B719 Hubs into B718 square knockouts
- Designed for use with B22, B24 & B26 Channel
- B718 Includes:
 - 1 pc. Junction Box only
 - 1 pc. Cover only
 - 2 pcs. #10-20 Round Head Machine Screws
- Standard finish: ZN
- Wt./C 180 Lbs. (81.6 kg)

Part No.	Includes	Wt./C	
		Lbs.	kg
B718-1	1 B718 & 1 B719	205	(93.0)
B718-2	1 B718 & 2 B719	230	(104.3)
B718-3	1 B718 & 3 B719	255	(115.6)
B718-4	1 B718 & 4 B719	280	(127.0)

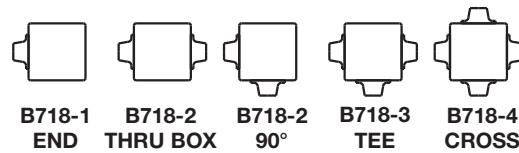

SELECTION GUIDE

Box Dimension:
2 1/2" Deep x 5 1/8" Square

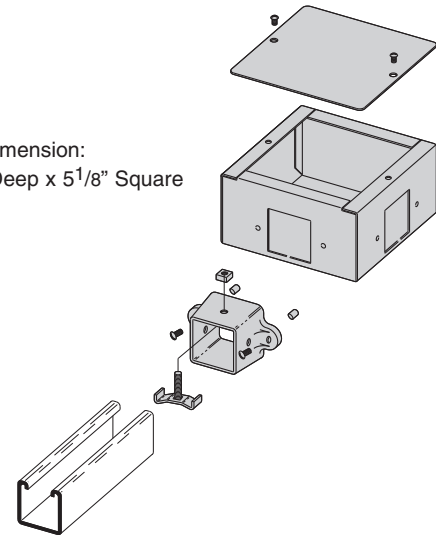

B719AL

UNIVERSAL JUNCTION BOX HUB

- B719AL Includes:
 - 1 pc. B719AL Hub only
 - 1 pc. B436S Fixture Stud Nut
 - 1 pc. 1/4"-20 Square Nut
 - 2 pcs. #10-24 Self Tapping Screws
 - 2 pcs. Rubber Caps
- Material: Aluminum
- Wt./C 25 Lbs. (11.3 kg)

B518-1 THRU B518-4

UNIVERSAL JUNCTION BOX AND HUBS

- Channel Connection Kits as shown in the chart above
- Includes:
 - 1 pc. Junction Box with Screws
 - 1 pc. Box Cover
- Standard finish: ZN

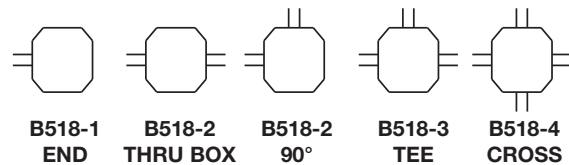

SELECTION GUIDE

Part No.	Channel Connection Kits Included	Wt./C	
		Lbs.	kg
B518-1	1	106	(48.1)
B518-2	2	137	(62.1)
B518-3	3	162	(78.5)
B518-4	4	192	(87.1)

CHANNEL CONNECTION KIT

- For use with B22, B24 & B26 Channels.
- Box Dimension: Standard 4" Octagon Box
- Includes:
 - 1 pc. B392-22-3/4 End Connection (See page 160)
 - 1 pc. 3/4" (20) Insulated Chase Nipple
 - 1 pc. 3/4" (20) Lock Nut
- Standard finish: ZN

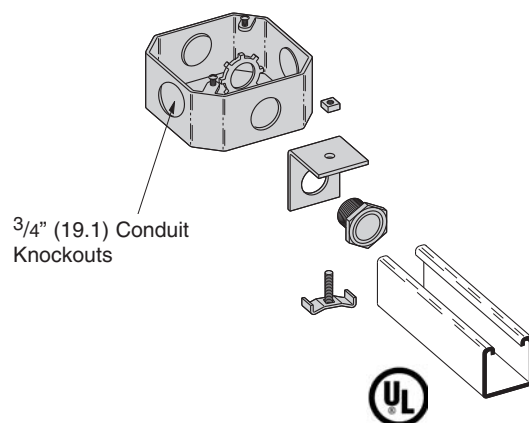

Reference page 162 for general fitting and standard finish specifications. U.L. Wire Fill Chart on pages 230 - 231.