

# Electrical Accessories

## B447 CONDUIT CONNECTION PLATE FOR 1/2" (15) CONDUIT

- Includes:
  - 2 pcs. 1/4"-20 Flat Head Machine Screws
  - 2 pcs. N224WO Channel Nuts
- Material: 16 Gauge (1.5)
- Standard finish: ZN
- Wt./C 35 Lbs. (15.9 kg)

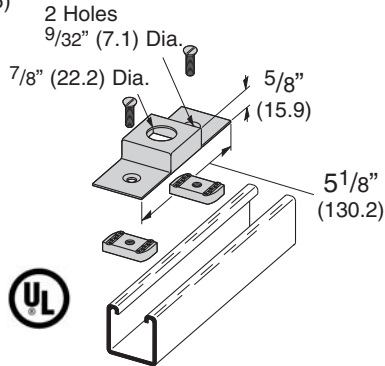

## B447A CONDUIT CONNECTION PLATE FOR 3/4" (20) CONDUIT

- Includes:
  - 2 pcs. 1/4"-20 Flat Head Machine Screws
  - 2 pcs. N224WO Channel Nuts
- Material: 16 Gauge (1.5)
- Standard finish: ZN
- Wt./C 35 Lbs. (15.9 kg)

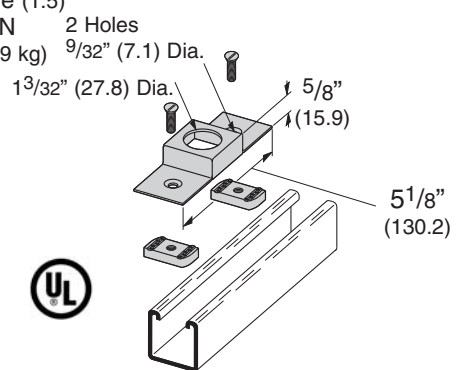

## B392-32 SERIES CONNECTION END CAP

- Includes:
  - 1 pc. 1/4"-20 Square Nut
  - 1 pc. B436S Fixture Stud Nut
- Material: 11 Gauge (3.0)
- Standard finish: ZN

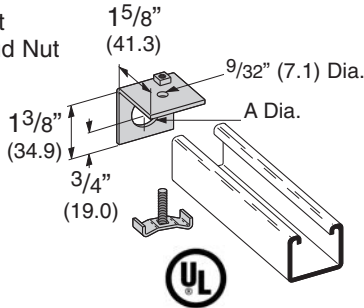

## B392-22 SERIES CONNECTION END CAP

- Includes:
  - 1 pc. 1/4"-20 Square Nut
  - 1 pc. B436S Fixture Stud Nut
- Material: 11 Gauge (3.0)
- Standard finish: ZN

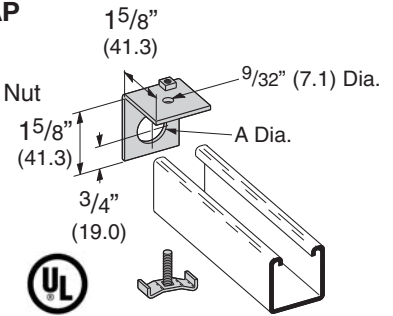

Part No.	A		Conduit Size		Wt./C	
					Lbs.	kg
B392-32-1/2	7/8"	(22.2)	1/2"	(15)	20	(9.1)
B392-32-3/4	1 1/16"	(27.0)	3/4"	(20)	19	(8.6)

Part No.	A		Conduit Size		Wt./C	
					Lbs.	kg
B392-22-1/2	7/8"	(22.2)	1/2"	(15)	21	(9.5)
B392-22-3/4	1 1/16"	(27.0)	3/4"	(20)	20	(9.1)
B392-22-1	1" PIPE THREAD		1"	(25)	17	(7.7)

## B392-12 SERIES CONNECTION END CAP

- Includes:
  - 1 pc. 1/4"-20 Square Nut
  - 1 pc. B436S Fixture Stud Nut
- Material: 11 Gauge (3.0)
- Standard finish: ZN

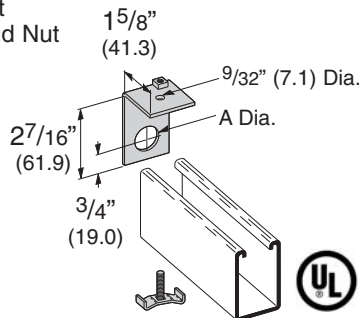

Part No.	A		Conduit Size		Wt./C	
					Lbs.	kg
B392-12-1/2	7/8"	(22.2)	1/2"	(15)	27	(12.2)
B392-12-3/4	1 1/16"	(22.7)	3/4"	(20)	26	(11.8)
B392-12-1	1" PIPE THREAD		1"	(25)	23	(10.4)

## B392-11 SERIES CONNECTION END CAP

- Includes:
  - 1 pc. 1/4"-20 Square Nut
  - 1 pc. B436S Fixture Stud Nut
- Material: 11 Gauge (3.0)
- Standard finish: ZN

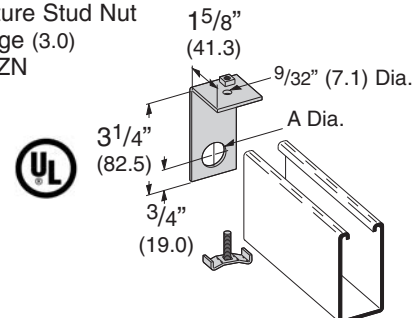

Part No.	A		Conduit Size		Wt./C	
					Lbs.	kg
B392-11-1/2	7/8"	(22.2)	1/2"	(15)	36	(16.3)
B392-11-3/4	1 1/16"	(27.0)	3/4"	(20)	33	(14.9)
B392-11-1	1" PIPE THREAD		1"	(25)	32	(14.5)

Reference page 162 for general fitting and standard finish specifications. U.L. Wire Fill Chart on pages 230 - 231.