

Insert Accessories

B205, B206, B220 X TYPE END CAPS

- UL listed for raceway use only
- Material: 12 Gauge (2.6)
- Standard finish: ZN

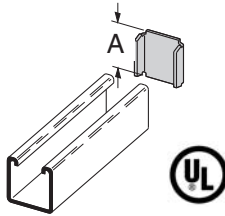

Part No.	Use With	A	Wt./C	
			Lbs.	kg
B205	B22	1 ²¹ / ₃₂ " (42.0)	10	(4.5)
B206	B32	1 ¹³ / ₃₂ " (35.7)	8	(3.6)
B220	B52	2 ⁷ / ₃₂ " (21.4)	4	(1.8)

B3322, B3332, B3342, B3352 Y TYPE END CAPS

- UL listed for raceway use only
- Material: 14 Gauge (1.9)
- Standard finish: ZN

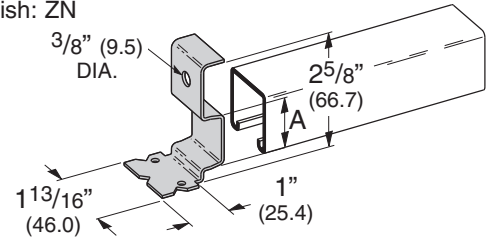

Part No.	Use With	A	Wt./C	
			Lbs.	kg
B3322	B22	1.270 (32.2)	15	(6.8)
B3332	B32	1.000 (25.4)	15	(6.8)
B3342	B42	.645 (16.4)	15	(6.8)
B3352	B52	.460 (11.7)	15	(6.8)

B380 JOINT SPLICE PLATE

- Used at splice points to prevent concrete seepage in long continuous runs of concrete inserts.
- Material: 18 Gauge (1.2)
- Standard finish: GALV

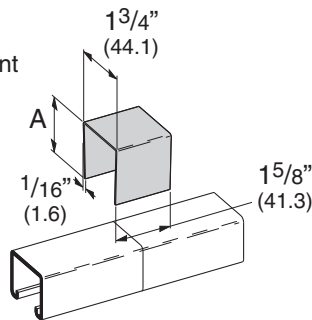

Part No.	Use With	A	Wt./C	
			Lbs.	kg
B380-22	B22	1 ⁵ / ₈ " (41.3)	11	(5.0)
B380-32	B32	1 ³ / ₈ " (34.9)	10	(4.5)
B380-42	B42	1" (25.4)	9	(4.1)
B380-52	B52	1 ³ / ₁₆ " (20.6)	7	(3.2)

B22IFS-B52IFS STYROFOAM FILLER STRIP

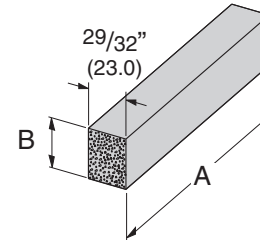

Part No.	A		B	Wt./C	
	Ft.	mm		Lbs.	kg
B22-IFS	4'	(1219)	1 ⁷ / ₃₂ " (309)	10	(4.5)
B32-IFS	4'	(1219)	1" (254)	9	(4.1)
B52-IFS	4'	(1219)	2 ¹ / ₃₂ " (167)	7	(3.2)

PIPE SLEEVE FASTENERS

- Allows for rigid attachment of pipe sleeves to wall and floor forms for concrete pouring.
- Accommodates Schedule 40, Schedule 80, or 5/16" (8) and smaller wall thickness.
- Simply installed with a hammer.

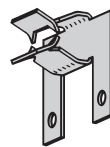

BD40



BE-5-8 & BE-9-12

Part No.	Sleeve Diameter	Wall Thickness
BD40	All Dia.	5/16" & under
BE-5-8	6"	Schedule 80 pipe
BE-9-12	9" - 14"	Schedule 80 pipe

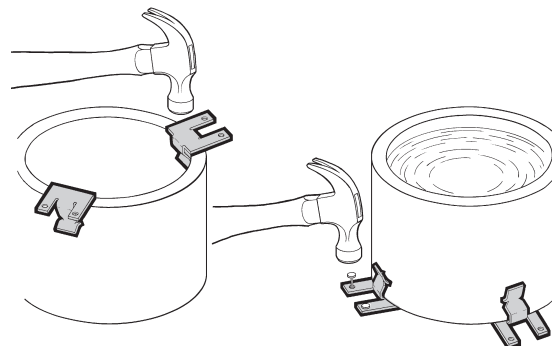

Reference page 212 for general fitting and standard finish specifications.

Concrete Inserts