

Continuous Concrete Inserts

B52I CONTINUOUS CONCRETE INSERT

- Design Load for B52-I-12 thru B52-I-240 is 1,500 lbs. (6.67 kN) per foot of concrete insert length with safety factor of 3 in 3000 psi concrete.
- Loads concentrated within the last 2 inches (50.8 mm) of concrete inserts 8" (203.2 mm) and longer should not exceed 750 lbs. (3.33kN).
- Concrete insert should be secured to the forms on 16" (406.4 mm) to 24" (609.6 mm) intervals.
- B52-I continuous concrete inserts are made from B52 channel. Use channel nuts designed for use in B52 channel.
- B52-I concrete inserts are supplied with styrofoam fillers. B3352 end caps are furnished with inserts through 8" (203.2 mm) long, and B220 end caps are furnished with inserts 12" (304.8 mm) and longer.
- Material: Plain Steel ASTM A1011 33,000 PSI min. yield or Pre-Galvanized Steel ASTM A653SS 33,000 PSI min. yield.
- Finish: Plain, Dura-Green, Pre-Galv, HDG

MATERIAL: 12 Gauge (2.6)

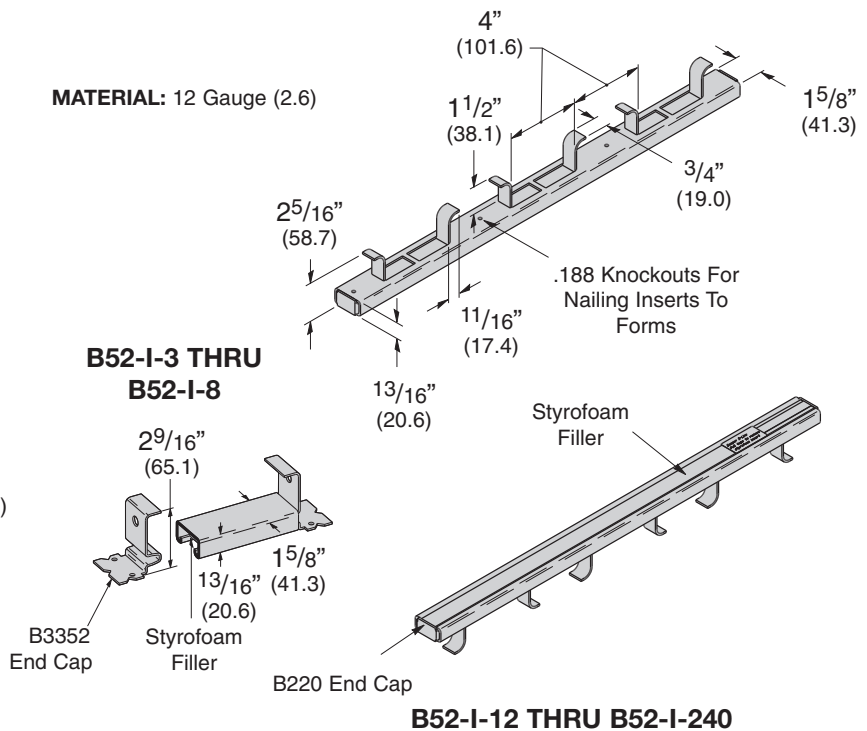

Part No.	Length		Wt./C		Design Load	
	in.	mm	Lbs.	kg	Lbs.	kN
B52-I-3	3"	(76)	53	(24.0)	400	(1.78)
B52-I-4	4"	(101)	63	(28.6)	500	(2.22)
B52-I-6	6"	(152)	85	(38.5)	750	(3.33)
B52-I-8	8"	(203)	106	(48.1)	1000	(4.45)

Part No.	Length		Wt./C	
	in.	mm	Lbs.	kg
B52-I-12	12"	(305)	157	(71.2)
B52-I-16	16"	(406)	202	(91.6)
B52-I-20	20"	(508)	237	(107.5)
B52-I-24	24"	(609)	282	(127.9)
B52-I-32	32"	(813)	373	(169.2)
B52-I-36	36"	(914)	419	(190.0)
B52-I-40	40"	(1016)	464	(210.4)
B52-I-48	48"	(1219)	556	(252.2)
B52-I-60	60"	(1524)	692	(313.9)
B52-I-72	72"	(1829)	829	(376.0)
B52-I-84	84"	(2133)	965	(437.7)
B52-I-96	96"	(2438)	1107	(502.1)
B52-I-108	108"	(2743)	1237	(561.1)
B52-I-120	120"	(3048)	1374	(623.2)
B52-I-144	144"	(3657)	1648	(747.5)
B52-I-168	168"	(4267)	1922	(871.8)
B52-I-192	192"	(4877)	2196	(996.1)
B52-I-216	216"	(5486)	2470	(1120.4)
B52-I-240	240"	(6096)	2744	(1244.6)

Reference page 212 for general fitting and standard finish specifications.