

Beam Clamps

B760-22 SERIES BEAM CLAMP

- 1" (25.4) Max. Flange Thickness
- For use with 1³/₁₆" (20.6) to 1⁵/₈" (41.3) high channel
- Recommended Torques:
U-Bolt Nuts 150 in-lbs. (16.9 N•m)
J-Hook Nut 60 in-lbs. (6.8 N•m)
- Includes:
1 pc. B760 Plate
1 pc. B701 Type J-Hook only
1 pc. B500-3³/₈" U-Bolt only
3 pcs. 3/8"-16 Hex Nuts
- Standard finish: ZN

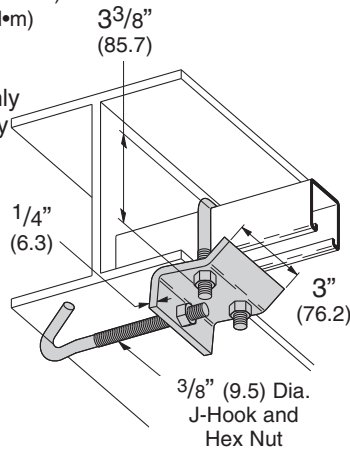

Part No.	For Flange Width		Wt./C	
	Lbs.	kg	Lbs.	kg
B760-22-J4	4"-5 ⁷ / ₈ "	(101.6-149.2)	122	(55.3)
B760-22-J6	6"-8 ⁷ / ₈ "	(152.4-225.4)	129	(58.5)
B760-22-J9	9"-11 ⁷ / ₈ "	(228.6-301.6)	135	(61.2)
B760-22-J12	12"-14 ⁷ / ₈ "	(304.8-377.8)	141	(63.9)

B760-22A SERIES BEAM CLAMP

- 1" (25.4) Max. Flange Thickness
- For use with 1⁵/₈" (41.3) to 3¹/₄" (82.5) high channel
- Recommended Torques:
U-Bolt Nuts 150 in-lbs. (16.9 N•m)
J-Hook Nut 60 in-lbs. (6.8 N•m)
- Includes:
1 pc. B760 Plate
1 pc. B701 Type J-Hook only
1 pc. B500-5" U-Bolt only
3 pcs. 3/8"-16 Hex Nuts
- Standard finish: ZN

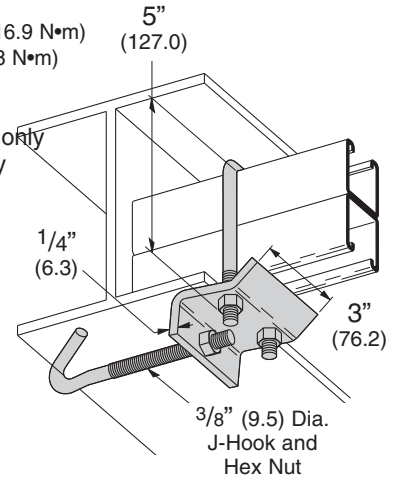

Part No.	For Flange Width		Wt./C	
	Lbs.	kg	Lbs.	kg
B760-22A-J4	4"-5 ⁷ / ₈ "	(101.6-149.2)	129	(58.5)
B760-22A-J6	6"-8 ⁷ / ₈ "	(152.4-225.4)	136	(61.7)
B760-22A-J9	9"-11 ⁷ / ₈ "	(228.6-301.6)	142	(64.4)
B760-22A-J12	12"-14 ⁷ / ₈ "	(304.8-377.8)	148	(67.1)

B761-22 SERIES BEAM CLAMP

- 1" (25.4) Max. Flange Thickness
- For use with 1³/₁₆" (20.6) to 1⁵/₈" (41.3) high channel
- Recommended Torques:
U-Bolt Nuts 150 in-lbs. (16.9 N•m)
ATR Nuts 60 in-lbs. (6.8 N•m)
- Includes:
2 pcs. B700 Plates
2 pcs. B500-3³/₈" U-Bolts only
1 pc. 3/8"-16 ATR (Length)
6 pcs. 3/8"-16 Hex Nuts
- Standard finish: ZN

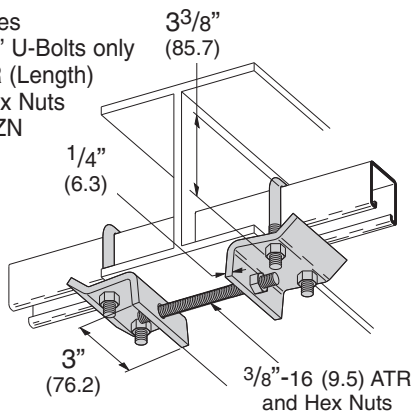

Part No.	For Flange Width		ATR Length		Wt./C	
	Lbs.	kg	Lbs.	kg	Lbs.	kg
B761-22-4	4"-5 ⁷ / ₈ "	(101.6-149.2)	4"	(101.6)	202	(91.6)
B761-22-6	6"-8 ⁷ / ₈ "	(152.4-225.4)	6"	(152.4)	206	(93.4)
B761-22-9	9"-11 ⁷ / ₈ "	(228.6-301.6)	9"	(228.6)	214	(97.0)
B761-22-12	12"-14 ⁷ / ₈ "	(304.8-377.8)	12"	(304.8)	221	(100.2)

B761-22A SERIES BEAM CLAMP

- 1" (25.4) Max. Flange Thickness
- For use with 1⁵/₈" (41.3) to 3¹/₄" (82.5) high channel
- Recommended Torques:
U-Bolt Nuts 150 in-lbs. (16.9 N•m)
ATR Nuts 60 in-lbs. (6.8 N•m)
- Includes:
2 pcs. B700 Plates
2 pcs. B500-5" U-Bolts only
1 pc. 3/8"-16 ATR (Length)
6 pcs. 3/8"-16 Hex Nuts
- Standard finish: ZN

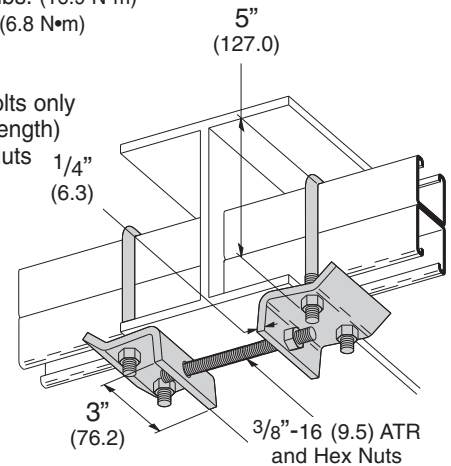

Part No.	For Flange Width		ATR Length		Wt./C	
	Lbs.	kg	Lbs.	kg	Lbs.	kg
B761-22A-4	4"-5 ⁷ / ₈ "	(101.6-149.2)	4"	(101.6)	216	(98.0)
B761-22A-6	6"-8 ⁷ / ₈ "	(152.4-225.4)	6"	(152.4)	220	(99.8)
B761-22A-9	9"-11 ⁷ / ₈ "	(228.6-301.6)	9"	(228.6)	228	(103.4)
B761-22A-12	12"-14 ⁷ / ₈ "	(304.8-377.8)	12"	(304.8)	235	(106.6)

Reference page 112 for general fitting and standard finish specifications.