

## B755 3/8" BEAM CLAMP

- Safety Factor of 5
- 5/8" (15.9) Max. Flange Thickness
- For 3/8"-16 Hanger Rod only.
- Material: 12 Gauge (2.6)
- Includes:

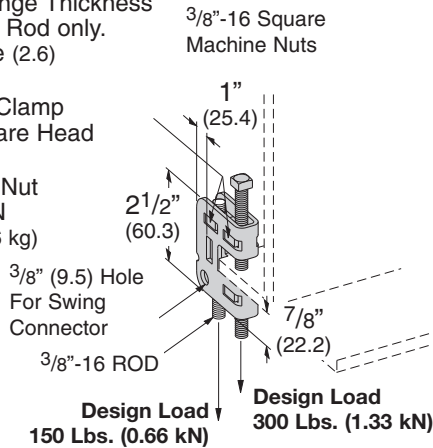

## B756-3/8 SWING CONNECTOR

- Design Load 150 Lbs. (0.66 kN)
- Safety Factor of 5
- Material: 12 Gauge (2.6)
- Includes:

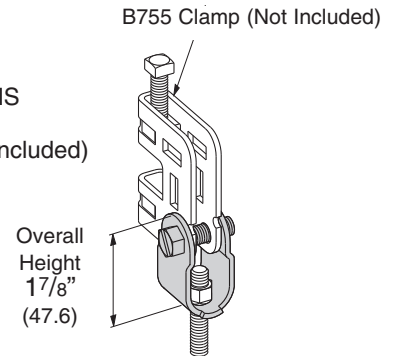

## B755-3/8-J BEAM CLAMP ASSEMBLY

- Includes:

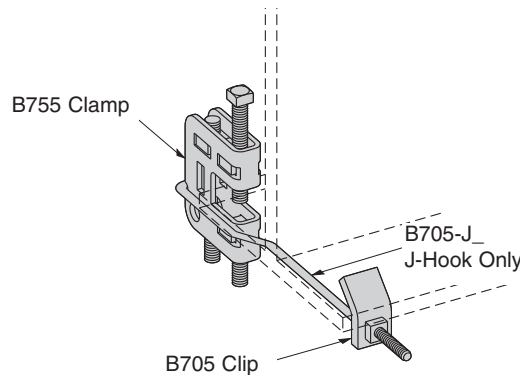

Part No.	For Flange Width		Wt./C	
			Lbs.	kg
B755-3/8-J4	4"-6"	(101.6-152.4)	47	(21.3)
B755-3/8-J6	6"-10"	(152.4-254.0)	51	(23.1)
B755-3/8-J10	10"-12"	(254.0-304.8)	53	(24.0)
B755-3/8-J12	12"-14"	(304.8-355.6)	55	(24.9)

## B702 CLEAT

- To eliminate the swiveling of the rod when required, use the B702 Cleat and a locking nut. This can be used with the B751 Beam Clamp, B752 Swivel or B756 Swing Connector.
- Material: 12 Gauge (2.6)
- Standard finish: ZN
- Wt./C 6 Lbs. (2.7 kg)

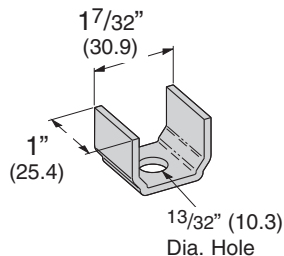

## B705 SERIES J-HOOK

- Use with B755-3/8
- Standard finish: ZN

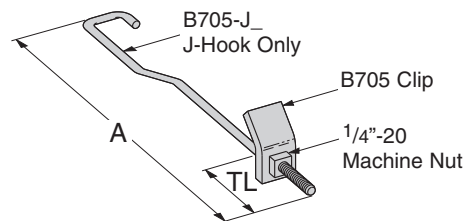

Part No.	A	Thread Length TL		Wt./C	
		Lbs.	kg	Lbs.	kg
B705-J4	7 3/8"	(187.3)	3"	(76.2)	17 (7.7)
B705-J6	11 3/8"	(288.9)	4 1/2"	(114.3)	21 (9.5)
B705-J10	13 3/8"	(339.7)	4 1/2"	(114.3)	23 (10.4)
B705-J12	15 3/8"	(390.5)	4 1/2"	(114.3)	25 (11.3)

Reference page 112 for general fitting and standard finish specifications.