

Slotted Angle

Cooper B-Line Slotted Angle is an all-purpose framing system, roll formed from high strength steel strips. It is designed to be used as economical shelving, racks or electrical and mechanical supports. The unique pattern of horizontal and vertical slots permits full flexibility. Three basic sizes are available for light, medium, and heavy duty applications.

Materials & Finishes*

Finish Code	Finish	Specification
PLN	Plain	ASTM A1011 33,000 PSI min. yield
ZN	Electro-Plated Zinc	ASTM B633 SC3
GRN	Dura-Green	
GALV	Pre-Galvanized	ASTM A653 33,000 PSI min. yield

*Unless otherwise noted.

Lengths

Standard lengths are 10' (3.05 m) and 12' (3.66 m). Slotted Angle is shipped in ten piece bundles complete with 75 pieces of $\frac{3}{8}$ " x $\frac{3}{4}$ " (19mm) hex head cap screws and $\frac{3}{8}$ " hex nuts.

Metric

Metric dimensions are shown in parentheses. Unless noted, all metric dimensions are in millimeters.

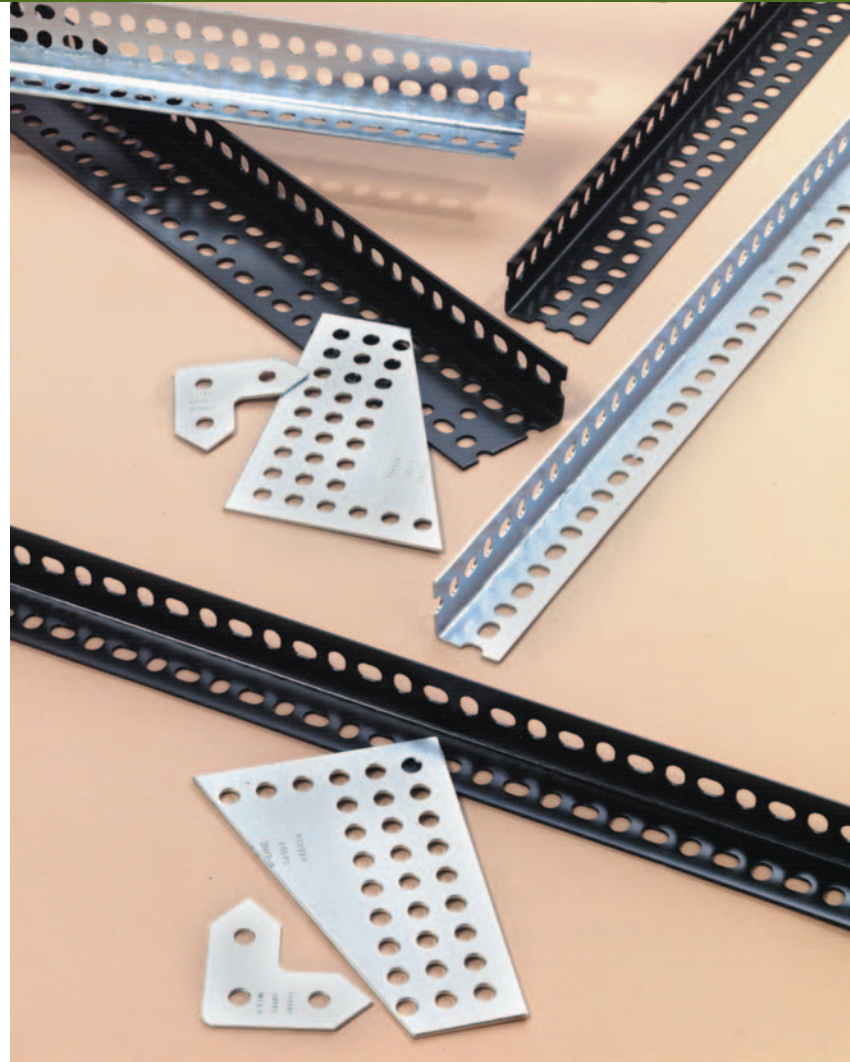

Slotted Angle Sizes

SA158

- 14 Gauge (1.9)
- 1⁵/₈" x 1⁵/₈"
- Standard finishes: ZN, GRN
- Wt./Ft. .66 Lbs. (.98 kg/m)

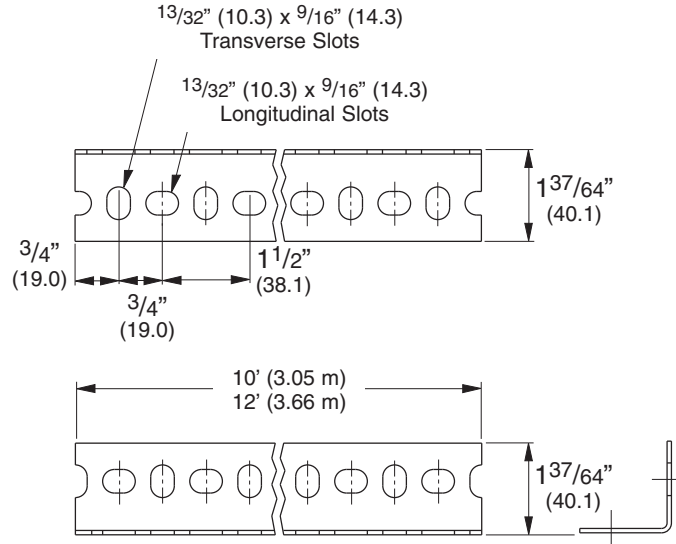
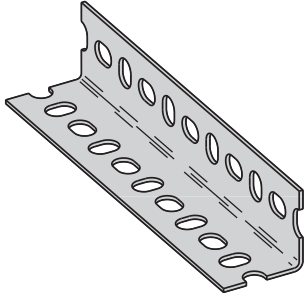

SA276

- 14 Gauge (1.9)
- 1⁵/₈" x 2³/₈"
- Standard finishes: ZN, GRN
- Wt./Ft. .78 Lbs. (1.17 kg/m)

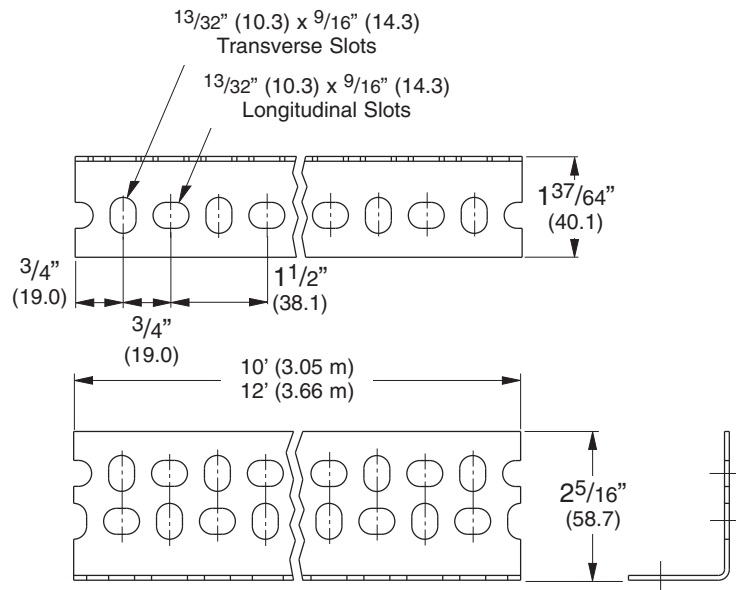
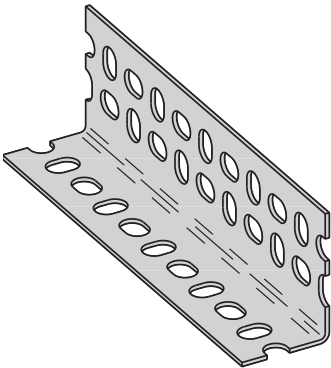

SA318

- 12 Gauge (2.6)
- 1⁵/₈" x 3¹/₈"
- Standard finishes: ZN, GRN
- Wt./Ft. 1.32 Lbs. (1.96 kg/m)

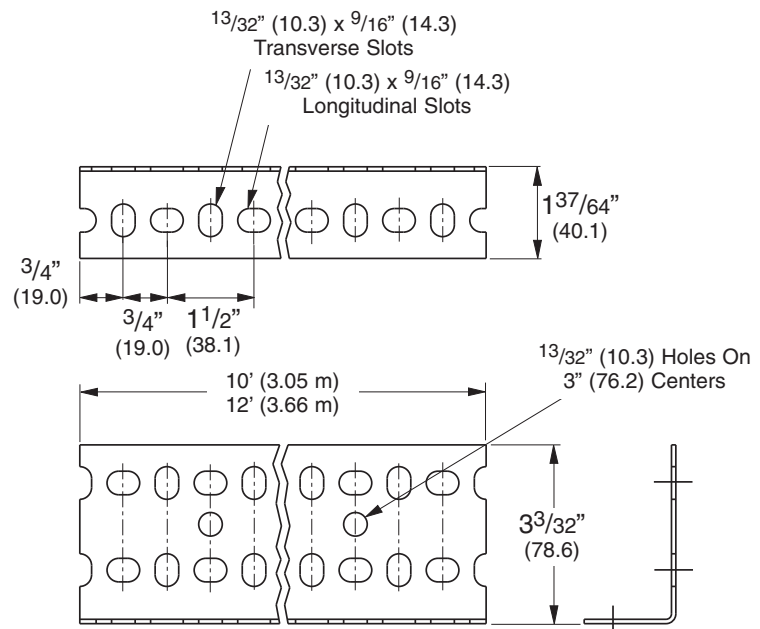
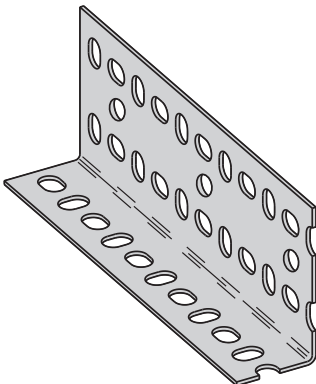

Reference page 222 for general fitting and standard finish specifications.

Slotted Angle Beam Loading & Combinations

BEAM SECTIONS

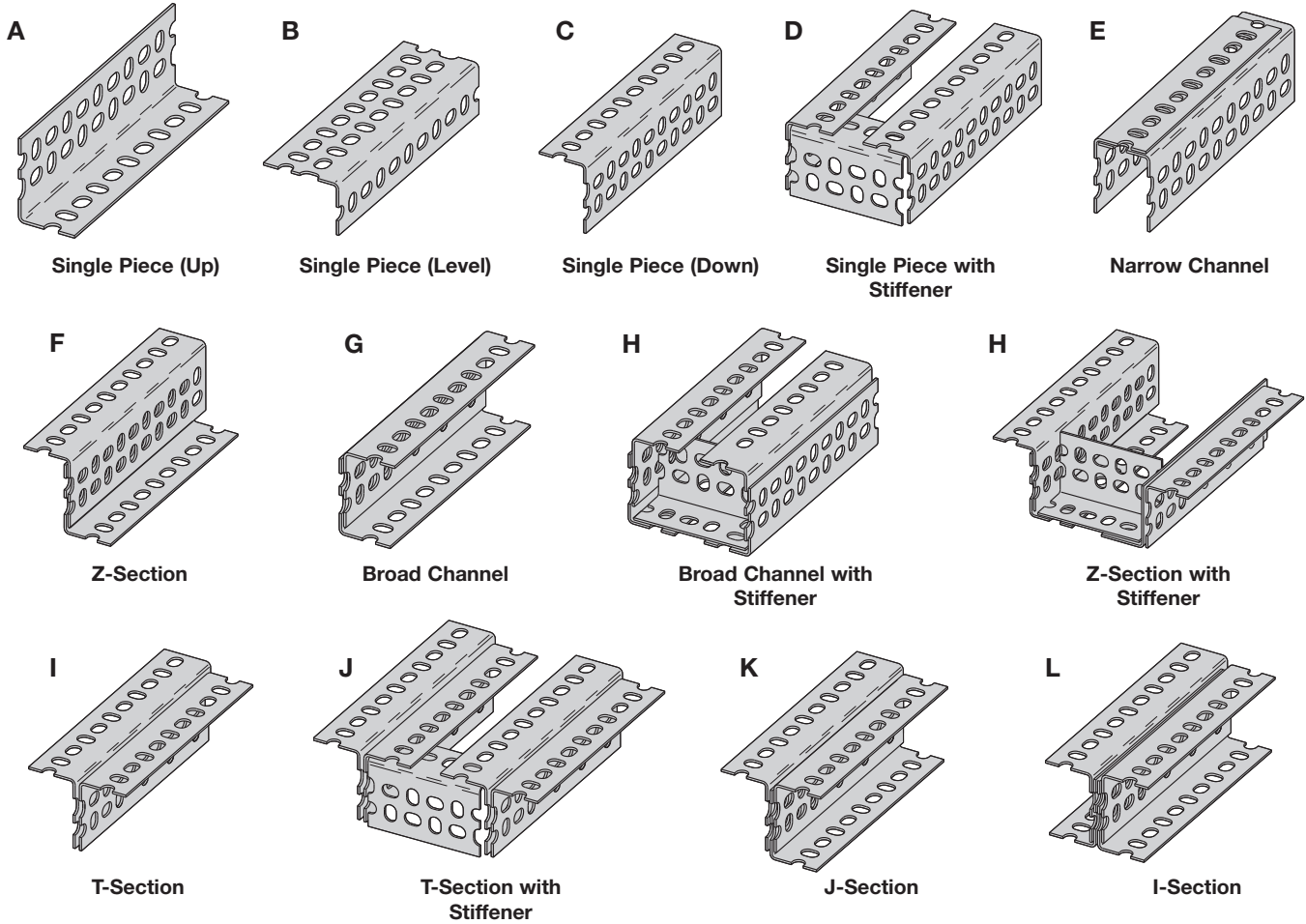

For greater strength required in some applications, Slotted Angle may be fastened together to create combination shapes. A number of these combinations are illustrated above. Refer to the following table for load capacities of these combinations.

Beam Sections illustrated are single sections, except J, N, and P.

BEAM LOADING

SA158-1⁵/₈" (41.3) x 1⁵/₈" (41.3) x 14 Gauge (1.9)

	Beam Span													
	24" (609 mm)		36" (914 mm)		48" (1219 mm)		60" (1524 mm)		72" (1829 mm)		84" (2133 mm)		96" (2438 mm)	
	Lbs.	N	Lbs.	N	Lbs.	N	Lbs.	N	Lbs.	N	Lbs.	N	Lbs.	N
A	825	(3670)	525	(2335)	340	(1512)	230	(1023)	180	(800)	-	-	-	-
B	1100	(4893)	800	(3558)	540	(2402)	370	(1646)	250	(1112)	-	-	-	-
C	1100	(4893)	800	(3558)	540	(2402)	370	(1646)	250	(1112)	-	-	-	-
D	1300	(5782)	900	(4003)	625	(2780)	450	(2001)	330	(1468)	275	(1223)	200	(889)
G	1900	(8451)	1360	(6049)	1050	(4670)	825	(3670)	660	(2936)	530	(2357)	400	(1779)
H	2300	(10231)	1850	(8229)	1450	(6450)	1100	(4893)	950	(4226)	800	(3558)	700	(3114)
I	2200	(9786)	1650	(7339)	1225	(5449)	930	(4137)	700	(3114)	550	(2446)	450	(2001)

Based on simple beam condition with uniform loads on parallel beams. To determine concentrated load capacity at mid-span, multiply uniform load by 0.5.

Reference page 222 for general fitting and standard finish specifications.

Slotted Angle Beam Loading

BEAM LOADING

SA276-1⁵/₈" (41.3) x 2³/₈" (60.3) x 14 Gauge (1.9)

	Beam Span																	
	24" (609 mm)		36" (914 mm)		48" (1219 mm)		60" (1524 mm)		72" (1829 mm)		84" (2133 mm)		96" (2438 mm)		108" (2743 mm)		120" (3048 mm)	
	Lbs.	N	Lbs.	N	Lbs.	N	Lbs.	N	Lbs.	N	Lbs.	N	Lbs.	N	Lbs.	N	Lbs.	N
A	-	-	680	(3025)	450	(2001)	340	(1512)	-	-	-	-	-	-	-	-	-	-
B	-	-	830	(3692)	550	(2446)	360	(1601)	210	(934)	150	(667)	-	-	-	-	-	-
C	-	-	1540	(6850)	1060	(4715)	800	(3558)	610	(2713)	480	(2135)	340	1512	250	(1112)	-	-
D	-	-	1880	(8362)	1280	(5694)	970	(4315)	820	(3647)	650	(2891)	550	(2446)	420	(1868)	340	(1512)
E	-	-	2110	(9386)	1730	(7695)	1460	(5775)	1250	(5560)	1090	(4848)	920	(4092)	820	(3647)	680	(3025)
F	4290	(19083)	2510	(11165)	1790	(7962)	1330	(5916)	980	(4359)	710	(3158)	550	(2446)	420	(1868)	320	(1423)
G	4320	(19216)	3000	(13344)	2140	(9519)	1600	(7117)	1290	(5738)	1040	(4626)	820	(3647)	640	(2847)	490	(2179)
H	-	-	3480	(15480)	2430	(10809)	1890	(8407)	1620	(7206)	1430	(6361)	1270	(5649)	1160	(5160)	1030	(4581)
I	5780	(25711)	3640	(16191)	2820	(12544)	2200	(9786)	1700	(7562)	1350	(6005)	1060	(4715)	850	(3781)	680	(3025)
J	-	-	3660	(16280)	2840	(12633)	2230	(9919)	1720	(7651)	1360	(6049)	1090	(4848)	874	(3888)	700	(3114)
K	-	-	4910	(21841)	3830	(17036)	3000	(13344)	2550	(11343)	2190	(9741)	1880	(8362)	1640	(7295)	1430	(6361)
L	-	-	6360	(28290)	4590	(20417)	3470	(15435)	2910	(12944)	2550	(11343)	2240	(9964)	2010	(8941)	1840	(8185)

Based on simple beam condition with uniform loads on parallel beams. To determine concentrated load capacity at mid-span, multiply uniform load by 0.5.

BEAM LOADING

SA318-1⁵/₈" (41.3) x 3¹/₈" (79.4) x 12 Gauge (2.6)

	Beam Span																	
	24" (609 mm)		36" (914 mm)		48" (1219 mm)		60" (1524 mm)		72" (1829 mm)		84" (2133 mm)		96" (2438 mm)		108" (2743 mm)		120" (3048 mm)	
	Lbs.	N	Lbs.	N	Lbs.	N	Lbs.	N	Lbs.	N	Lbs.	N	Lbs.	N	Lbs.	N	Lbs.	N
A	-	-	1140	(5071)	850	(3781)	690	(3069)	-	-	-	-	-	-	-	-	-	-
B	-	-	1250	(5560)	850	(3781)	600	(2669)	400	(1779)	-	-	-	-	-	-	-	-
C	4800	(21351)	2750	(12232)	1800	(8007)	1280	(5694)	1000	(4448)	790	(3514)	610	(2713)	-	-	-	-
D	-	-	3900	(17348)	2690	(11966)	2050	(9119)	1700	(7562)	1480	(6583)	1280	(5694)	1100	(4893)	960	(4270)
E	-	-	4160	(18504)	3560	(15835)	3130	(13923)	2750	(12232)	2400	(10676)	2170	(9652)	1950	(8674)	1780	(7918)
F	8180	(36386)	5000	(22241)	3650	(16236)	2750	(12232)	2200	(9786)	1750	(7784)	1350	(6005)	1020	(4537)	700	(3114)
G	10600	(47151)	6050	(26912)	4440	(19750)	3330	(14812)	2670	(11877)	2120	(9430)	1660	(7384)	1210	(5382)	1000	(4448)
H	-	-	6100	(27134)	4620	(20551)	3670	(16325)	3110	(13834)	2680	(11921)	2380	(10587)	2100	(9341)	1950	(8674)
I	13700	(60940)	7800	(34696)	5900	(26244)	4600	(20462)	3800	(16903)	3190	(14190)	2630	(11699)	2170	(9652)	1810	(8051)
J	-	-	7900	(35141)	6300	(28024)	5050	(22463)	4070	(18104)	3240	(14412)	2630	(11699)	2170	(9652)	1810	(8051)
K	-	-	10050	(44704)	8000	(35586)	6320	(28113)	5350	(23798)	4650	(20684)	4040	(17971)	3520	(15658)	3120	(13878)
L	-	-	12700	(56492)	9550	(42480)	7540	(33539)	6540	(29091)	5730	(25488)	5030	(22374)	4520	(20106)	4000	(17793)

Based on simple beam condition with uniform loads on parallel beams. To determine concentrated load capacity at mid-span, multiply uniform load by 0.5.

Reference page 222 for general fitting and standard finish specifications.

Slotted Angle Column Loading & Combinations

COLUMN SECTIONS

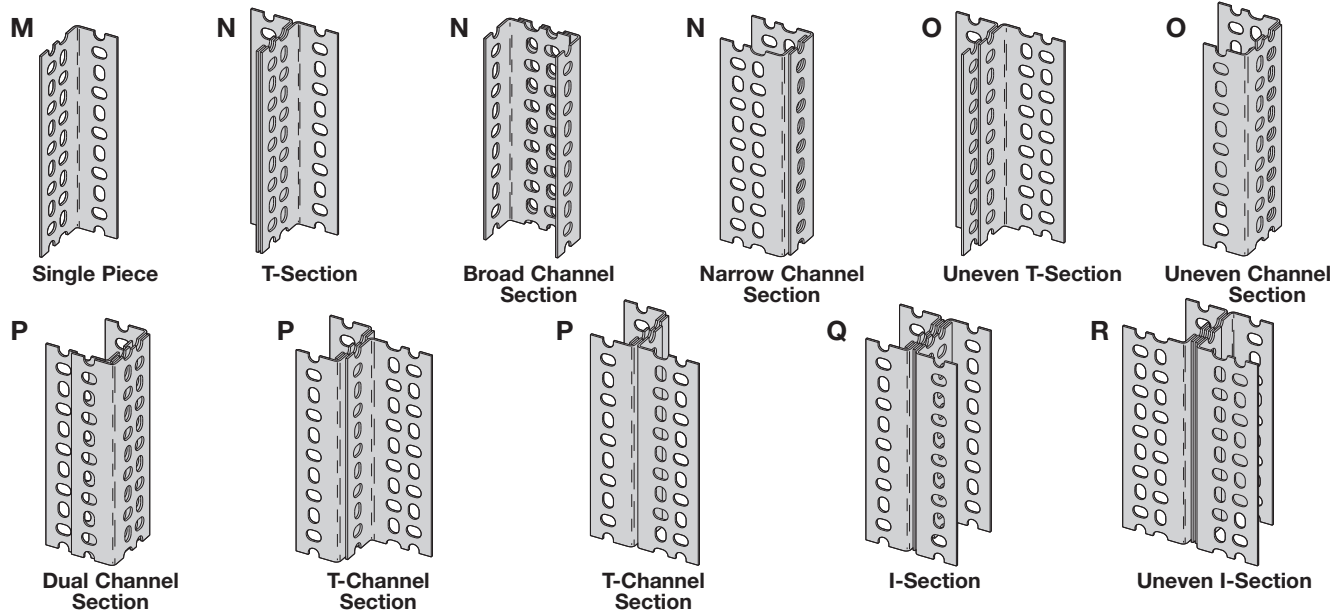

For greater strength required in some applications, Slotted Angle may be fastened together to create combination shapes. A number of these combinations are illustrated above. Refer to the following table for load capacities of these combinations.

COLUMN LOADING - SA158-1⁵/₈" (41.3) x 1⁵/₈" (41.3) x 14 Gauge (1.9)

	Column Height							
	36" (914 mm)		48" (1219 mm)		60" (1524 mm)		72" (1829 mm)	
	Lbs.	N	Lbs.	N	Lbs.	N	Lbs.	N
M	1450	(6450)	1150	(5115)	950	(4226)	750	(3336)
N	3850	(17125)	3500	(15569)	3000	(13344)	2500	(11120)

Column Loads assume no lateral support.

COLUMN LOADING - SA276-1⁵/₈" (41.3) x 2³/₈" (60.3) x 14 Gauge (1.9)

	Column Height															
	36" (914 mm)		48" (1219 mm)		60" (1524 mm)		72" (1829 mm)		84" (2133 mm)		96" (2438 mm)		108" (2743 mm)		120" (3048 mm)	
	Lbs.	N	Lbs.	N	Lbs.	N	Lbs.	N	Lbs.	N	Lbs.	N	Lbs.	N	Lbs.	N
M	2280	(10142)	1970	(8763)	1520	(6761)	1070	(4759)	660	(2936)	-	-	-	-	-	-
N	4760	(21173)	4490	(19972)	3995	(17770)	3140	(13967)	2340	(10409)	1750	(7784)	-	-	-	-
O	4940	(21974)	4680	(20817)	4310	(19172)	3870	(17214)	3665	(16303)	2700	(12010)	2060	(9163)	1610	(7161)
P	7270	(32338)	6920	(30781)	6370	(28335)	5840	(25977)	4930	(21930)	3850	(17125)	2870	(12766)	2060	(9163)
Q	9520	(42347)	8970	(39900)	7990	(35541)	6280	(27935)	4660	(20729)	3500	(15569)	-	-	-	-
R	9865	(43881)	9330	(41502)	8620	(38343)	7715	(34318)	6740	(29981)	5365	(23865)	4115	(18304)	3210	(14279)

Column Loads assume no lateral support.

COLUMN LOADING - SA318-1⁵/₈" (41.3) x 3¹/₈" (79.4) x 12 Gauge (2.6)

	Column Height															
	36" (914 mm)		48" (1219 mm)		60" (1524 mm)		72" (1829 mm)		84" (2133 mm)		96" (2438 mm)		108" (2743 mm)		120" (3048 mm)	
	Lbs.	N	Lbs.	N	Lbs.	N	Lbs.	N	Lbs.	N	Lbs.	N	Lbs.	N	Lbs.	N
M	3470	(15435)	2870	(12766)	1970	(8763)	1280	(5694)	-	-	-	-	-	-	-	-
N	7970	(35452)	7360	(32739)	6570	(29225)	5270	(23442)	3670	(16325)	2580	(11476)	-	-	-	-
O	8770	(39011)	8580	(38166)	8180	(36386)	7690	(34207)	6970	(31004)	6260	(27846)	5460	(24287)	4460	(19839)
P	12560	(55869)	11970	(53245)	11360	(50532)	10480	(46617)	9470	(42124)	8370	(37231)	6880	(30604)	5370	(23887)
Q	15940	(70904)	14750	(65611)	13160	(58538)	10560	(46973)	7370	(32783)	5170	(22997)	-	-	-	-
R	17550	(78066)	17150	(76287)	16360	(72773)	15360	(68324)	13970	(62141)	12570	(55914)	10970	(48797)	8960	(39856)

Column Loads assume no lateral support.

Reference page 222 for general fitting and standard finish specifications.

Slotted Angle Kits & Fittings

AHHK-1/4 & AHHK-3/8 AIR HANDLER HANGING KIT

- Standard finishes: ZN
- Load Capacity Per Kit: 400 Lbs. (181.4 kg)

- ⑧ Hanging rods come in 72" lengths.
Rods can be field cut for proper height requirement.

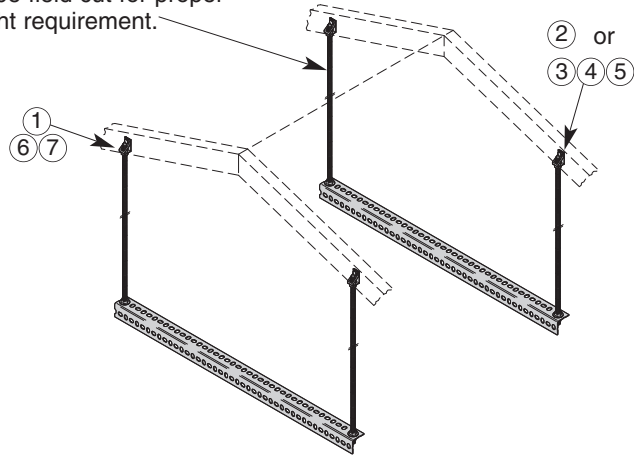

Item #	Description	Quantity	
		AHHK 1/4	AHHK 3/8
①	Rod Hanger Fitting	4	4
②	Lag Screw	4	4
③	Hex Head Cap Screw	4	4
④	Flat Washer (For HHCS)	4	4
⑤	Hex Nuts (For HHCS)	4	4
⑥	Hex Nuts (For Hanging Rods)	16	16
⑦	Flat Washer (See Note 1)	16	-
⑧	Hanging Rods (72" Long)	4	4
⑨	SA158 (36" Long)	2	2

Note 1: Flat washers are required for 1/4"-20 hanging rods only.

SA101 CONNECTION PLATE

- Standard finishes: ZN, GRN
- Wt./C 67 Lbs. (30.4 kg)

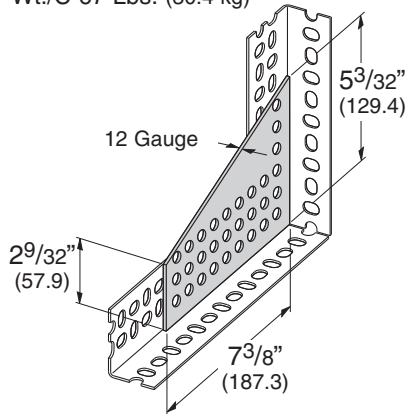

SA102 ANGLE BRACE

- Standard finishes: ZN, GRN
- Wt./C 15 Lbs. (6.8 kg)

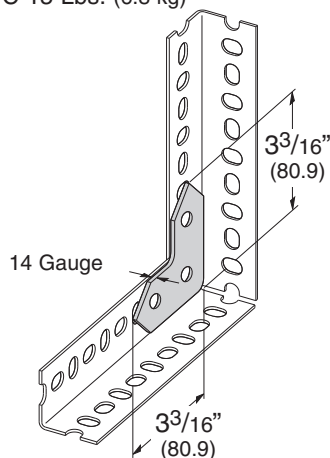

SA154 RIGID CASTER

- Safety Factor of 1.5
- 300 Lbs. (136.1 kg) maximum load capacity
- Caster material: Phenolic
- Standard finishes: ZN, GRN
- Wt./Ea. 2.0 Lbs. (.91 kg)

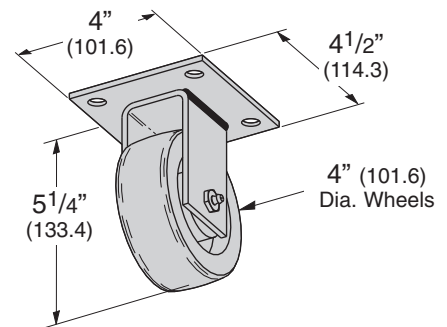

SA155 SWIVEL CASTER

- Safety Factor of 1.5
- 300 Lbs. (136.1 kg) maximum load capacity
- Caster material: Phenolic
- Standard finishes: ZN, GRN
- Wt./Ea. 2.2 Lbs. (1.0 kg)

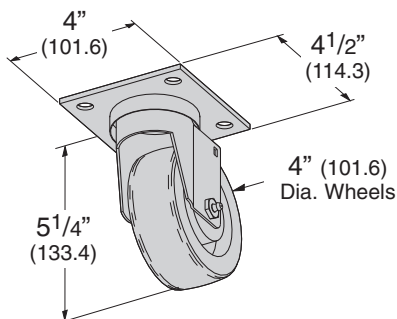

SA110 SLOTTED ANGLE CUTTER

- Standard finishes:
- Wt./Ea. 16 Lbs. (7.26 kg)

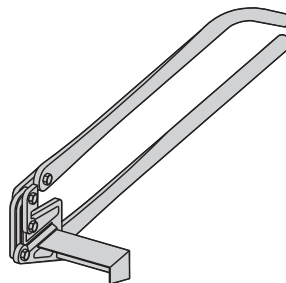

SA131 SLOTTED STRAP

- Hole pattern is identical to the hole pattern in slotted angles
- Standard length: 10' (3.05 m)
- Standard finishes: Pre-Galv. (GALV)
- Material thickness: 14 gauge (1.9)

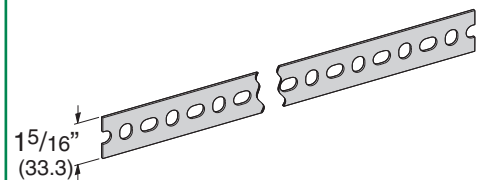

CLEATS: To reinforce load-bearing joints, cleats can be field made by cutting 2 1/4" (57.1) long segments from the widest slotted angle available. Use SA276 for light duty cleats and SA318 for heavy duty cleats.

SPLICE PLATES: To assemble two pieces of slotted angle using a butt joint requires a 6" (152.4) splice plate for reinforcement.

Reference page 222 for general fitting and standard finish specifications.