

Beam Clamps

Cooper B-Line's beam attachments and pipe supports offered in this section are designed to provide supports without drilling or welding. A complete selection of beam clamps, pipe clamps, rollers, supports and accessories are designed for use with Cooper B-Line channels and offer many installation advantages.

Materials & Finishes (Unless otherwise noted)

Pipe clamps, pipe hangers, beam clamps, brackets, and rollers are made from low carbon steel strips, plates or rod unless noted.

Finish Code	Finish	Specification
PLN	Plain	ASTM A1018 Gr. 33 ASTM A1011 SS Grade 33
ZN	Electro-Plated Zinc	ASTM B633 SC3 Type III or ASTM A653
GRN	Dura-Green	
-	Malleable Iron	ASTM A47 Gr. 32510
HDG	Hot-Dipped Galvanized	ASTM A123
CZ	Chromium Zinc	ASTM F1136
SS4	Stainless Steel Type 304	ASTM A240
SS6	Stainless Steel Type 316	ASTM A240
AL	Aluminum	ASTM B209

Note: A minimum order may apply on special material and finishes.

Load Data

The load data published includes a safety factor of 5.0 unless noted (safety factor = ratio of ultimate load to the design load).

Recommended Torque For Setscrews (unless noted)

Setscrew Size	1/4"-20	3/8"-16	1/2"-13
Foot/Lbs.	4	5	11
Nm	5	7	15

Setscrew Size	5/8"-11	3/4"-10
Foot/Lbs.	21	34
Nm	28	46

See chart on page 72 for bolt torque.

Metric

Metric dimensions are shown in parentheses. Unless noted, all metric dimensions are in millimeters.



B351L STEEL C-CLAMP WITH LOCKNUT

- Safety Factor of 5
- Setscrew and locknut included
- When Retaining Strap is required, order B3362, B3363 or B3365 separately
- Standard finishes: ZN, SS4, PLN

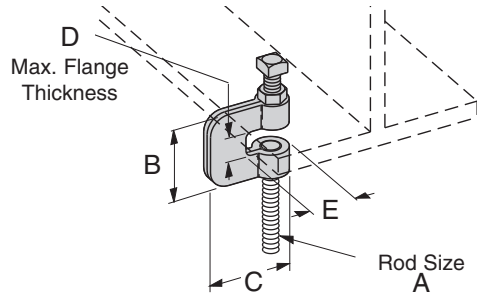

*
3/8 Thru 3/4
Sizes Only

Part Number With Locknut	Rod Size A	B		C		D		E		Design Load		Wt./C	
		Lbs.	kg	Lbs.	kg	Lbs.	kg	Lbs.	kg	Lbs.	kg	Lbs.	kg
B351L-3/8 *	3/8"-16	2 3/8"	(60.3)	2 3/8"	(60.3)	3/4"	(19.0)	1 3/8"	(34.9)	230	(1.03)	41	(18.6)
B351L-1/2 *	1/2"-13	2 3/8"	(60.3)	2 3/8"	(60.3)	3/4"	(19.0)	1 3/8"	(34.9)	380	(1.71)	41	(18.6)
B351L-5/8 *	5/8"-11	2 3/8"	(60.3)	2 1/4"	(57.1)	3/4"	(19.0)	1 3/8"	(34.9)	550	(2.47)	60	(27.2)
B351L-3/4 *	3/4"-10	2 3/8"	(60.3)	3 1/4"	(82.5)	3/4"	(19.0)	1 3/8"	(34.9)	630	(2.83)	71	(32.2)
B351L-7/8	7/8"-9	3"	(76.2)	3 1/4"	(82.5)	1"	(25.4)	1 7/8"	(47.6)	1200	(5.34)	184	(83.4)

B3036L C-CLAMP WITH LOCKNUT

- Safety Factor of 5
- When Retaining Strap is required, order B3363 or B3364 separately
- Setscrew and locknut included
- Material: Malleable iron
- Standard finishes: ZN, PLN

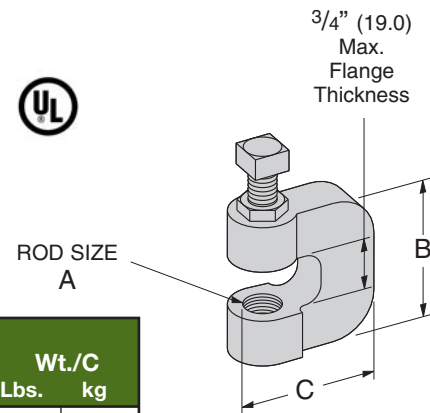

Part Number With Locknut	Rod Size A	B		C		Design Load		Wt./C	
		Lbs.	kg	Lbs.	kg	Lbs.	kg	Lbs.	kg
B3036L-3/8	3/8"-16	1 3/4"	(44.4)	1 3/4"	(44.4)	300	(0.89)	29	(13.1)
B3036L-1/2	1/2"-13	1 3/4"	(44.4)	1 3/4"	(44.4)	380	(1.69)	28	(12.7)
B3036L-5/8	5/8"-11	2"	(50.8)	1 7/8"	(47.6)	530	(2.36)	55	(24.9)
B3036L-3/4	3/4"-10	2"	(50.8)	2"	(50.8)	530	(2.36)	72	(32.6)

B3362 THRU B3365 RETAINING STRAP

- *When ordering specify L (Length) as a suffix to the part number
- Material: 14 Gauge (1.9)
- Standard finishes: GALV, SS4

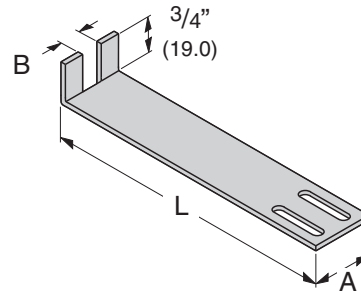

Part No.	Wt./C for Length L of				A	B	For Use With
	6" (152.4) Lbs. kg	8" (203.2) Lbs. kg	10" (254.0) Lbs. kg	12" (304.8) Lbs. kg			
B3362*	17 (7.7)	24 (10.9)	31 (14.0)	38 (17.2)	1 1/4" (31.7)	7/16" (11.1)	B351-3/8 & 1/2
B3363*	16 (7.2)	23 (10.4)	30 (13.6)	37 (16.8)	1 1/4" (31.7)	5/8" (15.9)	B351-5/8 & 3/4 B3036-3/8 & 1/2
B3364*	16 (7.2)	23 (10.4)	30 (13.6)	37 (16.8)	1 1/4" (31.7)	1 1/16" (17.4)	B3036-5/8 & 3/4
B3365*	21 (9.5)	29 (13.1)	37 (16.8)	46 (20.8)	1 1/2" (38.1)	3/4" (19.0)	B351-7/8

*See note above.

Reference page 112 for general fitting and standard finish specifications.

Beam Clamps

B3033 REVERSIBLE WIDE JAW WEDGE C-CLAMP (MALLEABLE IRON)

- Safety Factor of 5
- Setscrew and locknut included
- Material: Malleable iron
- Standard finishes: ZN, PLN

Throat Openings
 1 1/4" (31.7) For
 3/8 & 1/2 Sizes
 1 5/16" (33.3) For
 5/8 & 3/4 Sizes

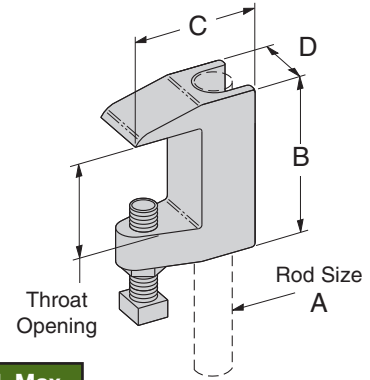

Part No.	Rod Size A	B	C	D	Design Load Lbs. kN	Wt./C Lbs. kg	UL Max. Pipe Size
B3033-3/8	3/8"-16	2 1/4" (57.1)	2" (50.8)	1 1/8" (28.6)	500 (2.22)	46 (20.8)	4" (100)
B3033-1/2	1/2"-13	2 5/16" (58.7)	2 3/16" (55.5)	1 1/4" (31.7)	810 (3.60)	64 (29.0)	8" (200)
B3033-5/8	5/8"-11	2 5/8" (66.7)	2 1/2" (63.5)	1 3/8" (34.9)	1000 (4.48)	116 (52.6)	8" (200)
B3033-3/4	3/4"-10	2 11/16" (68.3)	2 1/2" (63.5)	1 7/16" (36.5)	1400 (6.22)	140 (63.5)	10" (250)

B3034 WEDGE C-CLAMP

- Safety Factor of 5
- 3/4" (19.0) Max. Flange Thickness
- Setscrew and locknut included
- Material: Malleable iron
- Standard finishes: ZN, PLN

Note:
 3/8" & 1/2" Sizes
 Are Reversible
 Style



*
 3/8 & 1/2
 Sizes Only

3/4" (19.0) Max.
 Flange Thickness

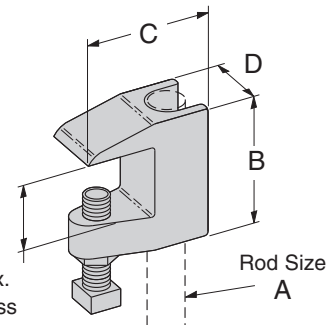

Part No.	Rod Size A	B	C	D	Design Load Lbs. kN	Wt./C Lbs. kg	UL Max. Pipe Size
B3034-3/8*	3/8"-16	1 5/8" (41.3)	2" (50.8)	7/8" (22.2)	560 (2.49)	54 (24.5)	4" (100)
B3034-1/2*	1/2"-13	1 13/16" (46.0)	2 3/16" (55.5)	1 3/16" (30.2)	810 (3.60)	51 (23.1)	8" (200)
B3034-5/8	5/8"-11	1 3/4" (44.5)	2 1/8" (54.0)	1 1/8" (28.6)	1000 (4.48)	70 (31.7)	-- --
B3034-3/4	3/4"-10	2" (50.8)	2 1/4" (57.2)	1 1/8" (28.6)	1500 (6.67)	98 (44.4)	-- --

Fig. 65XT REVERSIBLE C-TYPE BEAM CLAMP

- Safety Factor of 5
- 3/4" (19.0) Max. Flange Thickness
- Setscrew and locknut included
- Maximum Pipe Size 4" (100)
- Design Load 610 Lbs. (2.71kN)
- Material: Steel
- Standard finishes: ZN, PLN

Rod Size
 3/8"-16



3/4" (19.0) Max.
 Flange Thickness

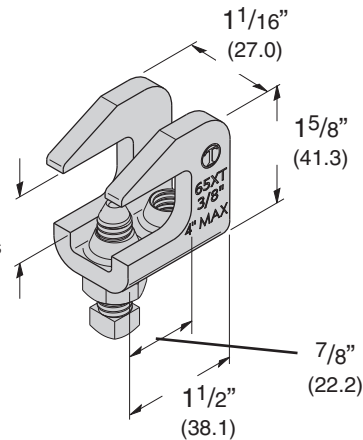

Reference page 112 for general fitting and standard finish specifications.

Fig. 69 (Formally B-Line B3367)
RETAINING STRAP

- Specify 'L' lengths required
- Minimum recommended return on strap is 1" (25.4)
- Material: Pre-Galvanized Steel
- Standard finishes: GALV

Part No.	Hole Dia. D		For Use With	Wt./C**	
				Lbs.	kg
69-3/8-L	7/16"	(30.1)	B3033-3/8 & B3034-3/8 65XT-3/8	23.9	(10.8)
69-1/2-L	9/16"	(30.1)	B3033-1/2 & B3034-1/2	23.6	(10.7)
69-5/8-L	11/16"	(50.8)	B3033-5/8	23.2	(10.5)
69-3/4-L	13/16"	(63.5)	B3033-3/4	22.7	(10.3)

** Wt./C based on 6" (152.4) length. For each additional inch in strap length add 4.2 Lbs (1.9 kg) to Wt./C.

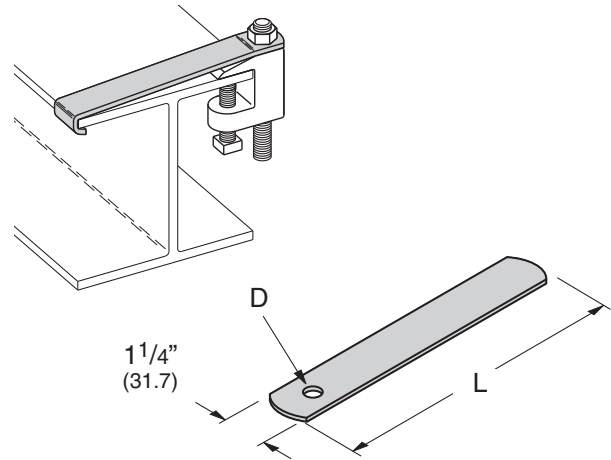
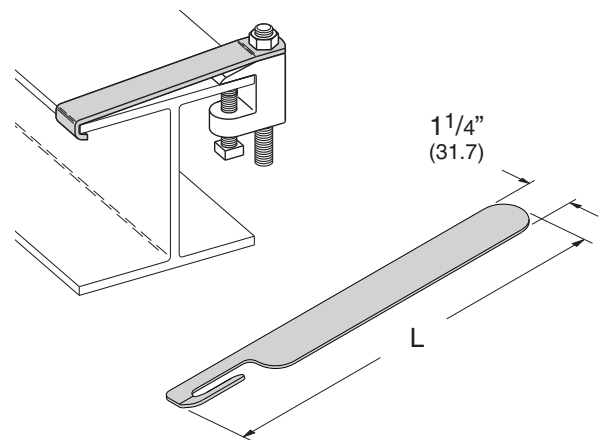

Fig. 69R
RETROFIT RETAINING STRAP

- Specify 'L' lengths required
- Minimum recommended return on strap is 1" (25.4)
- Material: Pre-Galvanized Steel
- Standard finishes: GALV

Part No.	Slot Width		For Use With	Wt./C**	
				Lbs.	kg
69R-3/8-L	7/16"	(30.1)	B3033-3/8 & B3034-3/8 65XT-3/8	22.9	(10.4)
69R-1/2-L	9/16"	(30.1)	B3033-1/2 & B3034-1/2	22.6	(10.2)

** Wt./C based on 6" (152.4) length. For each additional inch in strap length add 4.2 Lbs (1.9 kg) to Wt./C.



B3037Z
Z-PURLIN C-CLAMP

- Design Load 500 Lbs. (2.22 kN)
- Safety Factor of 5
- Designed for attaching a 3/8"-16 hanger rod to the bottom flange of a Z-purlin
- Setscrew and locknut included
- Material: Malleable iron
- Standard finishes: ZN, PLN

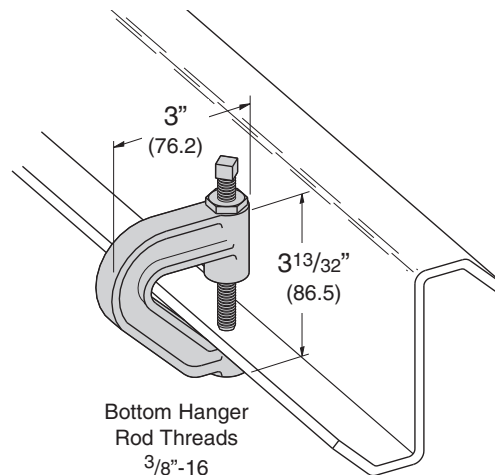

Reference page 112 for general fitting and standard finish specifications.

Beam Clamps

B444 SERIES ROD SUPPORT

- Safety Factor of 5
- Max. Flange Thickness
 $\frac{3}{4}$ " (19.0) for $\frac{1}{4}$ & $\frac{5}{16}$ sizes
 1 " (25.4) for $\frac{3}{8}$ & $\frac{1}{2}$ sizes
- Setscrew included
- Material: Malleable iron
- Standard finish: ZN
 Available in HDG with CZ Hardware

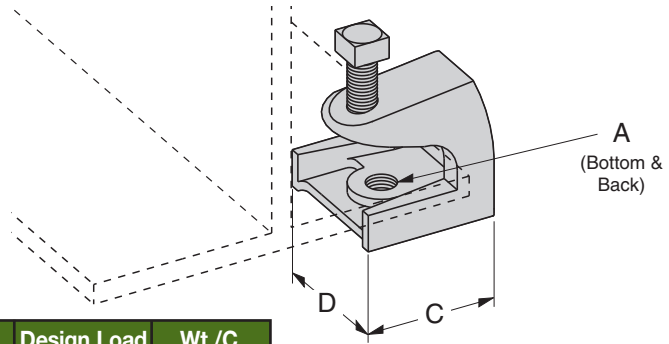

Part No.	Thread Size A	Set Screw	C		D		Design Load		Wt./C	
							Lbs.	kN	Lbs.	kg
B444-1/4	1/4"-20	1/4"-20	1 3/8"	(34.9)	1 3/16"	(30.1)	150	(.66)	24	(10.9)
B444-5/16	5/16"-18	1/4"-20	1 3/8"	(34.9)	1 3/16"	(30.1)	150	(.66)	23	(10.4)
B444-3/8	3/8"-16	1/2"-13	1 7/8"	(47.6)	2"	(50.8)	350	(7.12)	65	(29.5)
B444-1/2	1/2"-13	5/8"-11	2 3/8"	(60.3)	2 1/2"	(63.5)	1000	(4.45)	132	(59.9)

BC442 LIGHT DUTY BEAM CLAMP

- Design Load 75 Lbs. (.33 kN)
- Safety Factor of 5
- $\frac{11}{16}$ " (17.5) Max. Flange Thickness
- Setscrew included
- Holes tapped $\frac{1}{4}$ "-20 (Bottom & Back)
- Material: 13 Gauge (2.3)
- Standard finish: ZN
- Wt./C 13 Lbs. (3.9 kg)

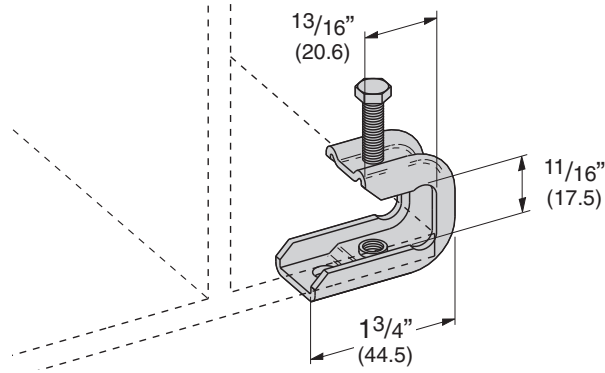

B210 BEAM CLAMP

- Design Load 800 Lbs. (3.56 kN)
- Safety Factor of 5
- $\frac{5}{8}$ " (15.9) Max. Flange Thickness
- $\frac{1}{2}$ "-13 Setscrew included
- Standard finish: ZN
- Wt./C 100 Lbs. (45.3 kg)

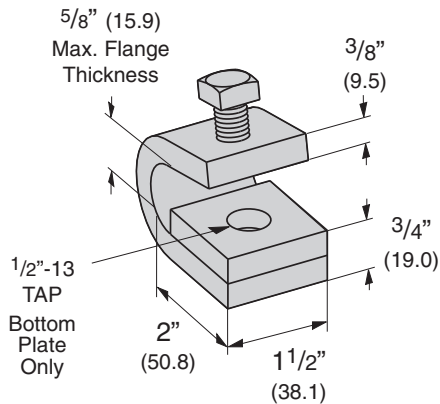

B210A BEAM CLAMP

- Design Load 300 Lbs. (1.33 kN)
- Safety Factor of 5
- $\frac{3}{4}$ " (19.0) Max. Flange Thickness
- $\frac{3}{8}$ "-16 Setscrew included
- Standard finish: ZN
- Wt./C 60 Lbs. (27.2 kg)

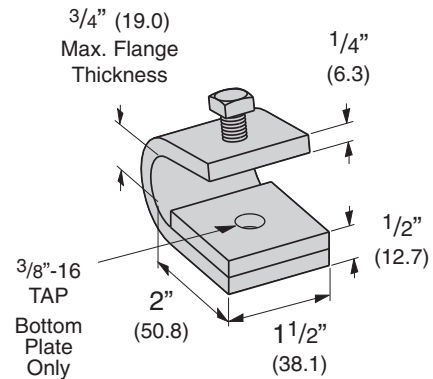

Reference page 112 for general fitting and standard finish specifications.

B303 THRU B309 BEAM CLAMPS

- Safety Factor of 5
- Max. Flange Thickness 1/16" (1.6) thru 7/8" (22.2)
- Setscrew included
- When Retaining Strap is required, order B312 separately
- Recommended Setscrew Torque: 3/8"-16 150 in-lbs. (16.9 N•m)
1/2"-13 350 in-lbs. (39.5 N•m)
- Standard finishes: ZN, HDG

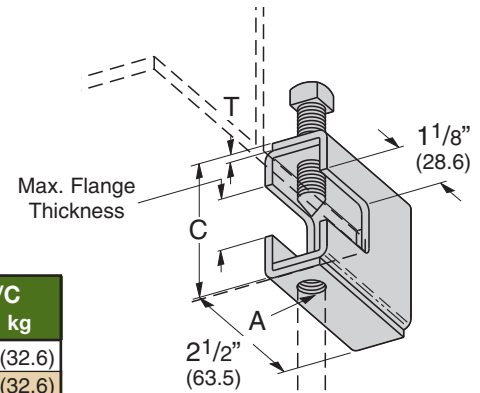

Part No.	Rod Size A	Set Screw	C	T	Design Load		Wt./C	
					Lbs.	kN	Lbs.	kg
B303	1/4"-20	3/8"-16	2 5/16" (58.7)	11 Ga. (3.0)	400	(1.78)	72	(32.6)
B304	5/16"-18	3/8"-16	2 5/16" (58.7)	11 Ga. (3.0)	600	(2.67)	72	(32.6)
B305	3/8"-16	3/8"-16	2 5/16" (58.7)	11 Ga. (3.0)	600	(2.67)	72	(32.6)
B306	3/8"-16	1/2"-13	2 7/16" (61.9)	7 Ga. (4.5)	1100	(4.89)	97	(44.0)
B307	1/2"-13	1/2"-13	2 7/16" (61.9)	7 Ga. (4.5)	1100	(4.89)	97	(44.0)
B308	1/2"-13	1/2"-13	2 9/16" (65.1)	1/4" (6.3)	1500	(6.67)	133	(60.3)
B309	5/8"-11	1/2"-13	2 9/16" (65.1)	1/4" (6.3)	1500	(6.67)	133	(60.3)

B321 SERIES BEAM CLAMPS

- Safety Factor of 5
- 1 11/16" (42.8) Max. Flange Thickness
- Setscrew included
- When Retaining Strap is required, order B312 separately
- Recommended Setscrew Torque: 1/2"-13 350 in-lbs. (39.5 N•m)
5/8"-11 700 in-lbs. (79.0 N•m)
- Minimum flange thickness: B321-1 thru B321-3 1/4" (6.3)
B321-4 and B321-5 3/8" (9.5)
- Standard finishes: ZN, HDG

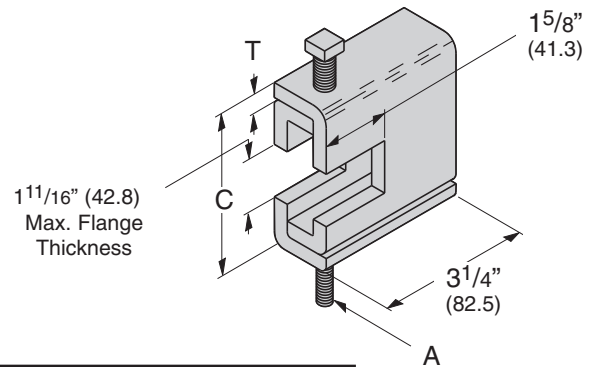

Part No.	Rod Size A	Setscrew	C	T	Design Load		Wt./C	
					Lbs.	kN	Lbs.	kg
B321-1	3/8"-16	1/2"-13	3 9/16" (92.1)	1/4" (6.3)	1300	(5.78)	187	(84.8)
B321-2	1/2"-13	1/2"-13	3 9/16" (92.1)	1/4" (6.3)	1400	(6.23)	186	(84.3)
B321-3	5/8"-11	1/2"-13	3 9/16" (92.1)	1/4" (6.3)	1600	(7.12)	185	(83.9)
B321-4	5/8"-11	5/8"-11	3 23/32" (94.4)	5/16" (7.9)	1800	(8.00)	239	(108.4)
B321-5	3/4"-10	5/8"-11	3 23/32" (94.4)	5/16" (7.9)	2000	(8.89)	238	(107.9)

B312 SERIES RETAINING STRAP FOR USE WITH B303 THRU B309 AND B321 SERIES

- 3/4" (19.0) Max. Flange Thickness
- For thicker beams, step up one flange width size
- Material: 14 Gauge (1.9)
- Standard finishes: GALV, HDG

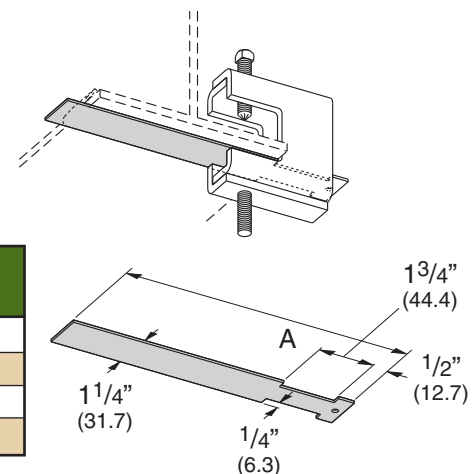

Part No.	For Flange Width		A	Wt./C	
				Lbs.	kg
B312-6	6"	(152.4)	9"	(228.6)	22 (10.0)
B312-9	9"	(228.6)	12"	(304.8)	30 (13.6)
B312-12	12"	(304.8)	15"	(381.0)	40 (18.1)
B312-15	15"	(381.0)	18"	(457.2)	49 (22.2)

Reference page 112 for general fitting and standard finish specifications.

Beam Clamps

B751 BEAM CLAMP

- Safety Factor of 5
- 3/4" (19.0) Max. Flange Thickness
- Setscrew and Locknut included
- Maximum ATR Size 1/2"
- Use B753 Swivel Nut (not included)
- Material: 12 Gauge (2.6)
- Standard finish: ZN, HDG
- Wt./C 42 Lbs. (19.0 kg)

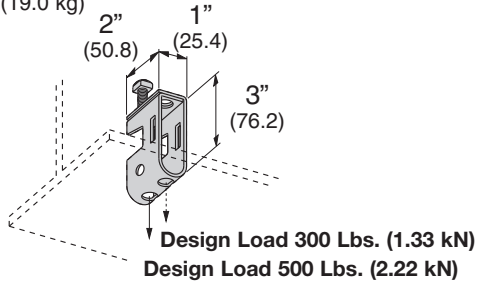

B752 BEAM CLAMP SWIVEL

- Design Load 500 Lbs. (2.22 kN)
- Safety Factor of 5
- Material: 12 Gauge (2.6)
- Use B753 Swivel Nut (not included)
- Includes:
 - 1 pc. B752 Swivel Body
 - 1 pc. 5/16"-18 x 1 3/4" HHCS
 - 1 pc. 5/16"-18 Hex Nut
- Standard finish: ZN
- Wt./C 30 Lbs. (13.6 kg)

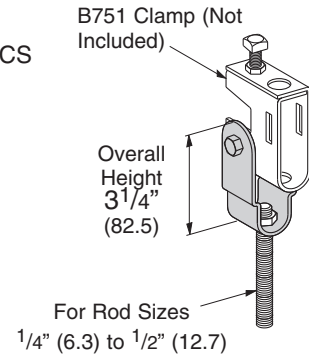

B751-J -3/8 BEAM CLAMP ASSEMBLY

- Includes:
 - 1 pc. B751 Beam Clamp
 - 1 pc. B701 Type J-Hook only
 - 1 pc. SA203-158 Clip
 - 1 pc. 3/8"-16 Hex Nut
- 1/4" (6.3) Diameter J-Hook available upon request
Part Number changes to B751-J_-1/4 and a 1/4"-20 Machine Square Nut (MSQN) is used
- Use B753 Swivel Nut (not included)
- Standard finishes: ZN

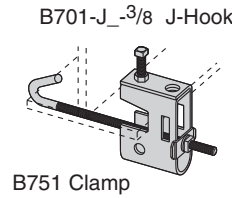

Part No.	For Flange Width		Wt./C	
			Lbs.	kg
B751-J4-3/8	3"-6"	(76.2-152.4)	70	(31.7)
B751-J6-3/8	5"-9"	(127.0-228.6)	78	(35.4)
B751-J9-3/8	8"-12"	(203.2-304.8)	83	(37.6)
B751-J12-3/8	11"-15"	(279.4-381.0)	88	(39.9)

B753 SWIVEL NUT

- Provides a full swivel of 15° in any direction
Specify rod size
- Standard finish: ZN

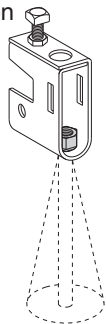

Part No.	For Rod Size	Wt./C	
		Lbs.	kg
B753-3/8	3/8"-16	4.0	(1.8)
B753-1/2	1/2"-13	3.4	(1.5)

B701 SERIES J-HOOK

- 1/4" (6.3) Diameter J-Hook available upon request
Part Number changes to B751-J_-1/4 and a 1/4"-20 Machine Square Nut (MSQN) is used
- Standard finish: ZN

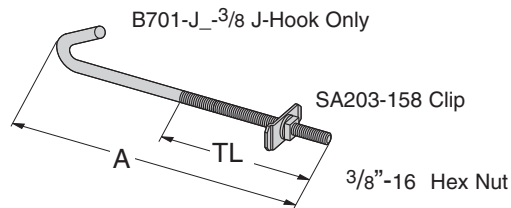

Part No.	A	Thread Length TL		Wt./C		
		Lbs.	kg	Lbs.	kg	
B701-J4-3/8	8 3/4"	(222.2)	5 1/2"	(139.7)	26	(11.8)
B701-J6-3/8	11 3/4"	(298.4)	6 1/2"	(165.1)	34	(15.4)
B701-J9-3/8	14 3/4"	(374.6)	6 1/2"	(165.1)	41	(18.6)
B701-J12-3/8	17 3/4"	(450.8)	6 1/2"	(165.1)	48	(21.8)

Reference page 112 for general fitting and standard finish specifications.

B755 3/8" BEAM CLAMP

- Safety Factor of 5
- 5/8" (15.9) Max. Flange Thickness
- For 3/8"-16 Hanger Rod only.
- Material: 12 Gauge (2.6)
- Includes:

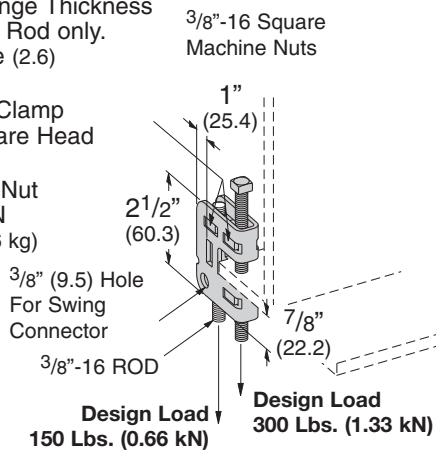

B756-3/8 SWING CONNECTOR

- Design Load 150 Lbs. (0.66 kN)
- Safety Factor of 5
- Material: 12 Gauge (2.6)
- Includes:

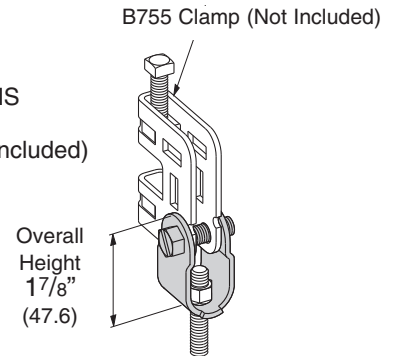

B755-3/8-J BEAM CLAMP ASSEMBLY

- Includes:

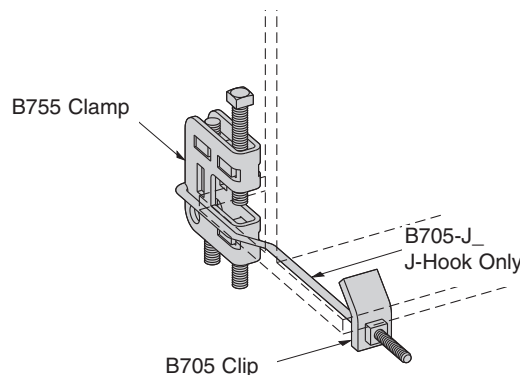

Part No.	For Flange Width		Wt./C	
	Lbs.	kg	Lbs.	kg
B755-3/8-J4	4"-6"	(101.6-152.4)	47	(21.3)
B755-3/8-J6	6"-10"	(152.4-254.0)	51	(23.1)
B755-3/8-J10	10"-12"	(254.0-304.8)	53	(24.0)
B755-3/8-J12	12"-14"	(304.8-355.6)	55	(24.9)

B702 CLEAT

- To eliminate the swiveling of the rod when required, use the B702 Cleat and a locking nut. This can be used with the B751 Beam Clamp, B752 Swivel or B756 Swing Connector.
- Material: 12 Gauge (2.6)
- Standard finish: ZN
- Wt./C 6 Lbs. (2.7 kg)

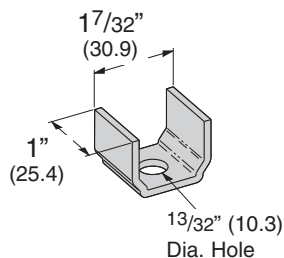

B705 SERIES J-HOOK

- Use with B755-3/8
- Standard finish: ZN

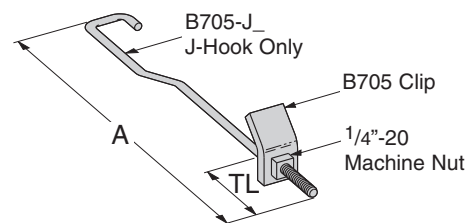

Part No.	A	Thread Length TL		Wt./C	
		Lbs.	kg	Lbs.	kg
B705-J4	7 3/8"	(187.3)	3"	(76.2)	17 (7.7)
B705-J6	11 3/8"	(288.9)	4 1/2"	(114.3)	21 (9.5)
B705-J10	13 3/8"	(339.7)	4 1/2"	(114.3)	23 (10.4)
B705-J12	15 3/8"	(390.5)	4 1/2"	(114.3)	25 (11.3)

Reference page 112 for general fitting and standard finish specifications.

Beam Clamps

B750 SERIES BEAM CLAMP

- Safety Factor of 5
- Design Load 500 Lbs. (2.22 kN)
- Recommended Torque:
J-Hook Nut 125 in-lbs. (14.1 N•m)
- Maximum Flange Thickness $5/8"$ (15.9)
- Standard finish: ZN

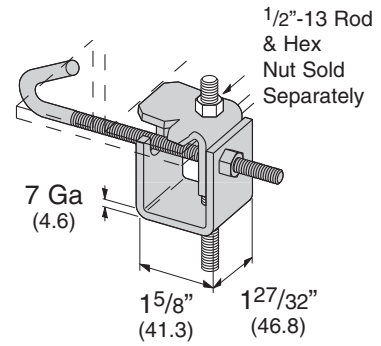

Part No.	For Flange Width		Wt./C	
			Lbs.	kg
B750-J4	3"-6"	(76.2-152.4)	109	(49.4)
B750-J6	5"-9"	(127.0-228.6)	124	(56.2)
B750-J9	8"-12"	(203.2-304.8)	135	(61.2)
B750-J12	11"-15"	(279.4-381.0)	147	(66.7)

B700 SERIES J-HOOK

- Includes:
1 pc. J-Bolt
1 pc. Hex Nut
- Maximum Flange Thickness $5/8"$ (15.9)
- Standard finish: ZN

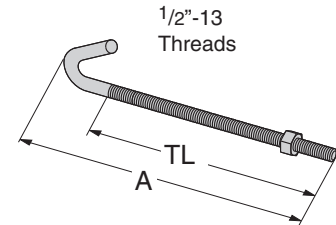

Part No.	A		Thread Length TL		Wt./C	
	Lbs.	kg	Lbs.	kg	Lbs.	kg
B700-J4	8 $1/2"$	(215.9)	6 $3/4"$	(171.4)	44	(19.9)
B700-J6	11 $1/2"$	(292.1)	9 $3/4"$	(247.6)	53	(24.0)
B700-J9	14 $1/2"$	(368.3)	12 $3/4"$	(323.8)	63	(28.6)
B700-J12	17 $1/2"$	(444.5)	15 $3/4"$	(400.0)	78	(35.4)

B500 SERIES SQUARE U-BOLT

- Includes:
1 pc. U-Bolt only
2 pcs. $3/8"$ -16 Hex Nuts
- Additional sizes available
- Standard finish: ZN, SS4

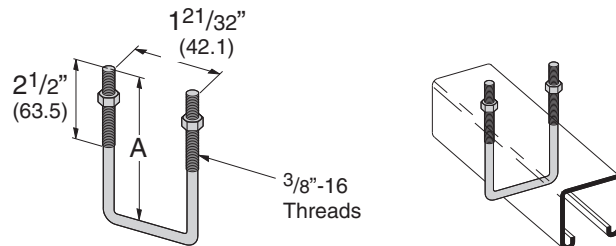

Part No.	A		Channel Size	Wt./C	
	Lbs.	kg		Lbs.	kg
B500-3-3/8	3 $3/8"$	(85.7)	1 $5/8"$ x 1 $5/8"$	25	(11.3)
B500-5	5"	(127.0)	3 $1/4"$ x 1 $5/8"$	33	(14.9)

Reference page 112 for general fitting and standard finish specifications.

B441-22 BEAM CLAMP

- Design Load 1200 Lbs. (5.34 kN) when used in pairs
- Safety Factor of 5
- 3/4" (19.0) Max. Flange Thickness
- For use with 13/16" (20.6) to 15/8" (41.3) high channel
- Recommended Torque: 150 in-lbs. (16.9 N•m)
- Sold in pieces
- Other flange thickness variations are available, contact B-Line Engineering for sizes
- Standard finishes: ZN, HDG, SS4
- Wt./C 87 Lbs. (39.4 kg)

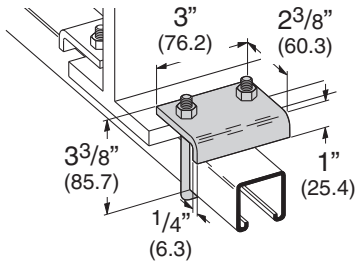

B441-22A BEAM CLAMP

- Design Load 1200 Lbs. (5.34 kN) when used in pairs
- Safety Factor of 5
- 3/4" (19.0) Max. Flange Thickness
- For use with 15/8" (41.3) to 3 1/4" (82.5) high channel
- Recommended Torque: 150 in-lbs. (16.9 N•m)
- Sold in pieces
- Other flange thickness variations are available, contact B-Line Engineering for sizes
- Standard finishes: ZN, HDG, SS4
- Wt./C 93 Lbs. (42.2 kg)

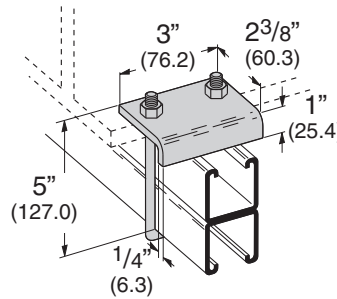

B314 BEAM CLAMP

- Design Load 900 Lbs. (4.00 kN) when used in pairs
- Safety Factor of 5
- 5/8" (15.9) Max. Flange Thickness
- For use with channel 15/8" (41.3) in height
- Setscrew included
- Sold in pieces.
- Standard finishes: ZN, GRN, HDG, SS4
- Wt./C 105 Lbs. (47.6 kg)

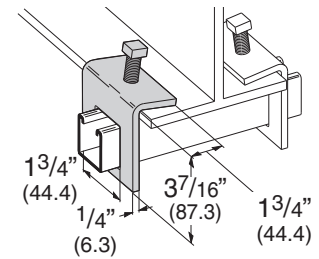

B441Z-22 BEAM CLAMP

- Design Load 1200 Lbs. (5.34 kN) when used in series
- Safety Factor of 5
- Sold in pieces
- For use with 13/16" (20.6) to 15/8" (41.3) high channel
- Recommended Torque: 150 in-lbs. (16.9 N•m)
- Standard finishes: ZN
- Wt./C 95 Lbs. (43.1 kg)

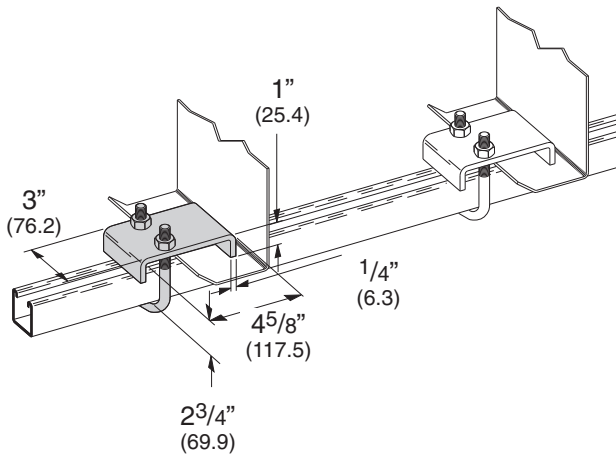

B441Z-22A BEAM CLAMP

- Design Load 1200 Lbs. (5.34 kN) when used in series
- Safety Factor of 5
- Sold in pieces
- For use with 15/8" (41.3) to 3 1/4" (82.5) high channel
- Recommended Torque: 150 in-lbs. (16.9 N•m)
- Standard finishes: ZN
- Wt./C 101 Lbs. (45.8 kg)

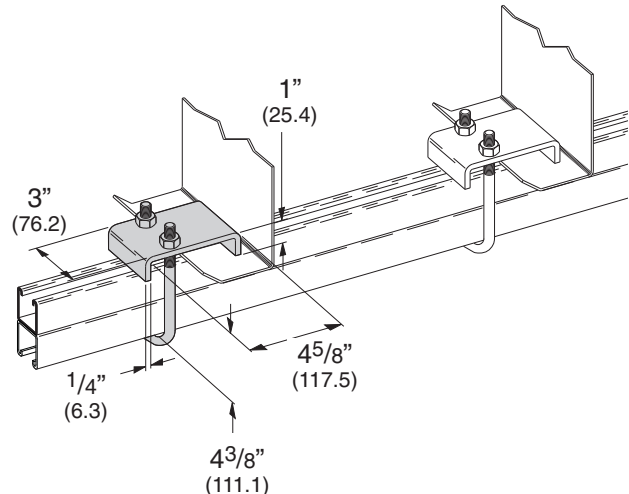

Reference page 112 for general fitting and standard finish specifications.

Beam Clamps

B211 ZEE BEAM CLAMP

- Design Load 600 Lbs. (2.67 kN) when used in pairs
- Safety Factor of 5
- 1" (25.4) Max. Flange Thickness
- 1/2"-13 Setscrew included
- Sold in pieces
- Order 1/2"-13 HHCS and Channel Nut separately
- Standard finishes: ZN, HDG
- Wt./C 66 Lbs. (29.9 kg)

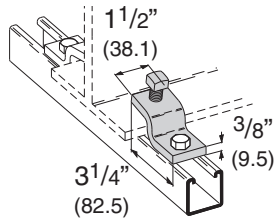

B213 I-BEAM CLAMP

- Design Load 900 Lbs. (4.00 kN) when used in pairs
- Safety Factor of 5
- 7/8" (22.2) Max. Flange Thickness
- 1/2"-13 Setscrew included
- Sold in pieces
- Order 1/2"-13 x 2 1/4" HHCS and Channel Nut separately
- Material: Malleable iron
- Standard finishes: ZN, GRN
- Wt./C 95 Lbs. (43.1 kg)

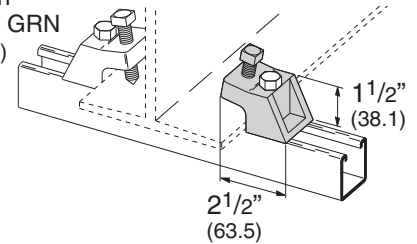

B355 BEAM CLAMP

- Design Load 1200 Lbs. (5.34 kN) when used in pairs
- Safety Factor of 5
- 5/8" (15.9) Max. Flange Thickness
- Sold in pieces
- Order 1/2"-13 x 1 1/2" HHCS and Channel Nut separately
- Standard finishes: ZN, GRN, HDG, SS4
- Wt./C 30 Lbs. (13.6 kg)

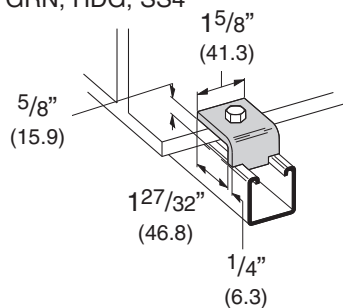

B212-1/4 I-BEAM CLAMP

- Design Load 600 Lbs. (2.67 kN) when used in pairs
- Safety Factor of 5
- 7/8" (22.2) Max. Flange Thickness
- 3/8"-16 Setscrew included
- Sold in pieces
- Standard finish: ZN
- Wt./C 41 Lbs. (18.6 kg)

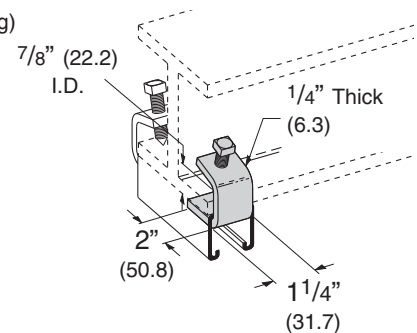

B212-3/8 I-BEAM CLAMP

- Design Load 1000 Lbs. (4.45 kN) when used in pairs
- Safety Factor of 5
- 1 1/8" (28.6) Max. Flange Thickness
- 1/2"-13 Setscrew included
- Sold in pieces
- Standard finishes: ZN, HDG
- Wt./C 62 Lbs. (28.1 kg)

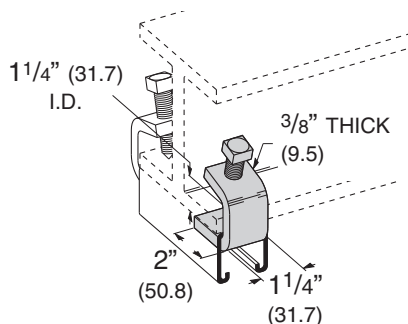

B435 BEAM CLAMP

- Design Load 900 Lbs. (4.00 kN) when used in pairs
- Safety Factor of 5
- 2 1/8" (54.0) Max. Flange Thickness
- 1/2"-13 x 2" Setscrew included
- Sold in pieces
- Standard finish: ZN
- Wt./C 82 Lbs. (37.2 kg)

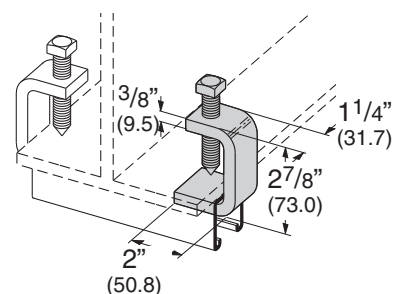

Reference page 112 for general fitting and standard finish specifications.

B427 BEAM CLAMP

- Design Load 1100 Lbs. (4.89 kN) when used in pairs
- Safety Factor of 5
- 2 1/2" (63.5) Max. Flange Thickness without channel
- 1/2"-13 x 1 1/2" Setscrew included
- Sold in pieces
- Standard finish: ZN
- Wt./C 92 Lbs. (41.7 kg)

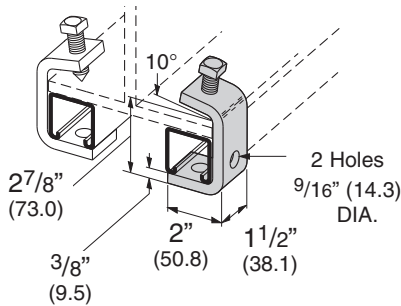

B405 SUSPENSION MEMBER

- Standard finishes: ZN, GRN
- Wt./C 75 Lbs. (34.0 kg)

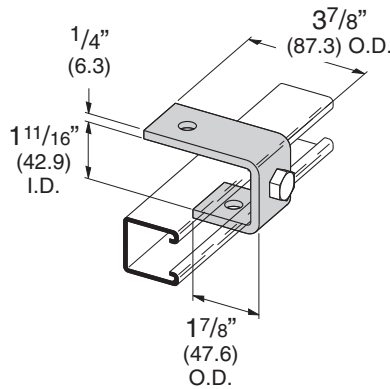

B405A SUSPENSION MEMBER WITH BEAM CLAMP

- 7/8" (22.2) Max. Flange Thickness
- Includes:
 - 1 pc. B405 Suspension Member
 - 1 pc. B213 I-Beam Clamp
 - 1 pc. 1/2"-13 x 2 1/2" HHCS
 - 1 pc. 1/2"-13 Hex Nut
- Material: Malleable iron
- Standard finishes: ZN, GRN
- Wt./C 183 Lbs. (83.0 kg)

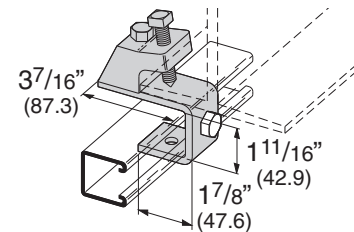

B318 THRU B320 BEAM CLAMP ASSEMBLY

- Safety Factor of 5
- 7/8" (22.2) Max. Flange Thickness
- Includes:
 - 1 pc. B333 Slotted U-Support
 - 2 pcs. B213 I-Beam Clamp
 - 2 pcs. 1/2"-13 x 2 1/2" HHCS
 - 2 pcs. 1/2"-13 Hex Nuts
- Material: Malleable iron
- Standard finishes: ZN, GRN

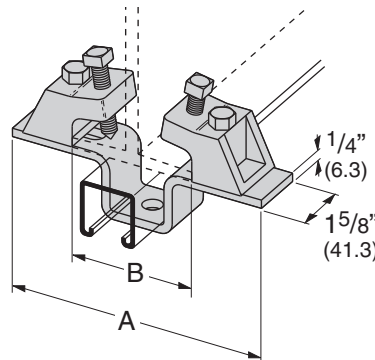

Part No.	A	For Flange Width B	Design Load Lbs. kN	Wt./C Lbs. kg
B318	7 1/4" (184.1)	2 3/8"-4 1/2" (60.3-114.3)	1200 (5.34)	325 (147.4)
B319	8 1/2" (215.9)	3 3/4"-5 3/4" (95.2-146.0)	800 (3.56)	340 (154.2)
B320	10 3/8" (263.5)	5 5/8"-7 5/8" (142.9-193.7)	560 (2.49)	357 (161.9)

B602A THRU B602C BEAM CLAMP WITH GUSSET ASSEMBLY

- Safety Factor of 5
- 7/8" (22.2) Max. Flange Thickness
- Includes:
 - 1 pc. B451 Slotted Three Hole U Support with Gusset
 - 2 pcs. B213 I-Beam Clamp
 - 2 pcs. 1/2"-13 x 2 1/2" HHCS
 - 2 pcs. 1/2"-13 Hex Nuts
- Material: Malleable iron
- Standard finishes: ZN, GRN

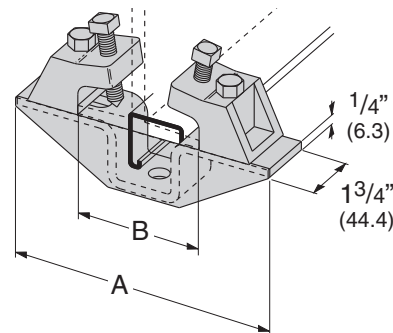

Part No.	A	For Flange Width B	Design Load Lbs. kN	Wt./C Lbs. kg
B602A	7 1/4" (184.1)	2 3/8"-4 1/2" (60.3-114.3)	1200 (5.34)	365 (165.1)
B602B	8 1/2" (215.9)	3 3/4"-5 3/4" (95.2-146.0)	1200 (5.34)	383 (173.7)
B602C	10 3/8" (263.5)	5 5/8"-7 5/8" (142.9-193.7)	1200 (5.34)	408 (185.0)

Reference page 112 for general fitting and standard finish specifications.

Beam Clamps

B760-22 SERIES BEAM CLAMP

- 1" (25.4) Max. Flange Thickness
- For use with 1³/₁₆" (20.6) to 1⁵/₈" (41.3) high channel
- Recommended Torques:
U-Bolt Nuts 150 in-lbs. (16.9 N•m)
J-Hook Nut 60 in-lbs. (6.8 N•m)
- Includes:
1 pc. B760 Plate
1 pc. B701 Type J-Hook only
1 pc. B500-3³/₈" U-Bolt only
3 pcs. 3/8"-16 Hex Nuts
- Standard finish: ZN

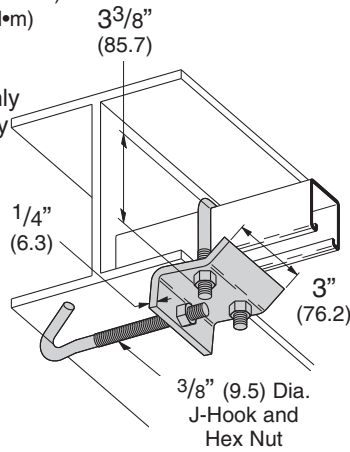

Part No.	For Flange Width		Wt./C	
	Lbs.	kg	Lbs.	kg
B760-22-J4	4"-5 ⁷ / ₈ "	(101.6-149.2)	122	(55.3)
B760-22-J6	6"-8 ⁷ / ₈ "	(152.4-225.4)	129	(58.5)
B760-22-J9	9"-11 ⁷ / ₈ "	(228.6-301.6)	135	(61.2)
B760-22-J12	12"-14 ⁷ / ₈ "	(304.8-377.8)	141	(63.9)

B760-22A SERIES BEAM CLAMP

- 1" (25.4) Max. Flange Thickness
- For use with 1⁵/₈" (41.3) to 3¹/₄" (82.5) high channel
- Recommended Torques:
U-Bolt Nuts 150 in-lbs. (16.9 N•m)
J-Hook Nut 60 in-lbs. (6.8 N•m)
- Includes:
1 pc. B760 Plate
1 pc. B701 Type J-Hook only
1 pc. B500-5" U-Bolt only
3 pcs. 3/8"-16 Hex Nuts
- Standard finish: ZN

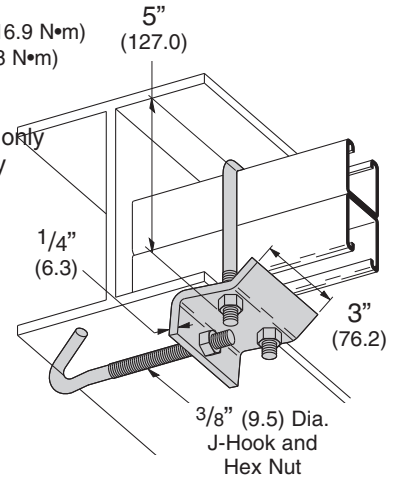

Part No.	For Flange Width		Wt./C	
	Lbs.	kg	Lbs.	kg
B760-22A-J4	4"-5 ⁷ / ₈ "	(101.6-149.2)	129	(58.5)
B760-22A-J6	6"-8 ⁷ / ₈ "	(152.4-225.4)	136	(61.7)
B760-22A-J9	9"-11 ⁷ / ₈ "	(228.6-301.6)	142	(64.4)
B760-22A-J12	12"-14 ⁷ / ₈ "	(304.8-377.8)	148	(67.1)

B761-22 SERIES BEAM CLAMP

- 1" (25.4) Max. Flange Thickness
- For use with 1³/₁₆" (20.6) to 1⁵/₈" (41.3) high channel
- Recommended Torques:
U-Bolt Nuts 150 in-lbs. (16.9 N•m)
ATR Nuts 60 in-lbs. (6.8 N•m)
- Includes:
2 pcs. B700 Plates
2 pcs. B500-3³/₈" U-Bolts only
1 pc. 3/8"-16 ATR (Length)
6 pcs. 3/8"-16 Hex Nuts
- Standard finish: ZN

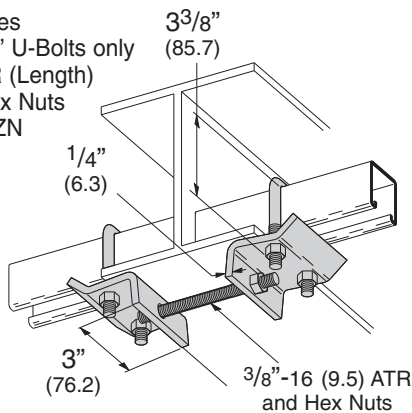

Part No.	For Flange Width		ATR Length		Wt./C	
	Lbs.	kg	Lbs.	kg	Lbs.	kg
B761-22-4	4"-5 ⁷ / ₈ "	(101.6-149.2)	4"	(101.6)	202	(91.6)
B761-22-6	6"-8 ⁷ / ₈ "	(152.4-225.4)	6"	(152.4)	206	(93.4)
B761-22-9	9"-11 ⁷ / ₈ "	(228.6-301.6)	9"	(228.6)	214	(97.0)
B761-22-12	12"-14 ⁷ / ₈ "	(304.8-377.8)	12"	(304.8)	221	(100.2)

B761-22A SERIES BEAM CLAMP

- 1" (25.4) Max. Flange Thickness
- For use with 1⁵/₈" (41.3) to 3¹/₄" (82.5) high channel
- Recommended Torques:
U-Bolt Nuts 150 in-lbs. (16.9 N•m)
ATR Nuts 60 in-lbs. (6.8 N•m)
- Includes:
2 pcs. B700 Plates
2 pcs. B500-5" U-Bolts only
1 pc. 3/8"-16 ATR (Length)
6 pcs. 3/8"-16 Hex Nuts
- Standard finish: ZN

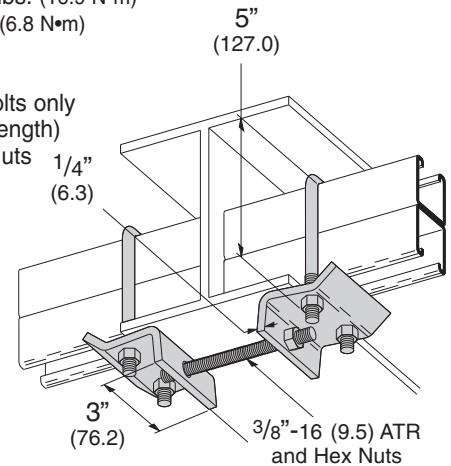

Part No.	For Flange Width		ATR Length		Wt./C	
	Lbs.	kg	Lbs.	kg	Lbs.	kg
B761-22A-4	4"-5 ⁷ / ₈ "	(101.6-149.2)	4"	(101.6)	216	(98.0)
B761-22A-6	6"-8 ⁷ / ₈ "	(152.4-225.4)	6"	(152.4)	220	(99.8)
B761-22A-9	9"-11 ⁷ / ₈ "	(228.6-301.6)	9"	(228.6)	228	(103.4)
B761-22A-12	12"-14 ⁷ / ₈ "	(304.8-377.8)	12"	(304.8)	235	(106.6)

Reference page 112 for general fitting and standard finish specifications.

B614 COLUMN SUPPORT FOR B22

- Quick installation (one bolt to tighten)
- Design Load 800 Lbs. (3.56 kN) Slip with Safety Factor of 3
- Use with B22 and B24 Channel
- Sold in pairs
- Standard finish: ZN
- Wt./C 50 Lbs. (22.6 kg)

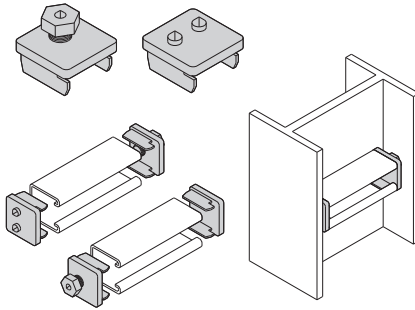

B613 COLUMN SUPPORT FOR B22

- Design Load 800 Lbs. (3.56 kN) Slip with Safety Factor of 3
- Use with B22 and B24 Channel
- Setscrews to be torqued to 19 ft./Lbs
- Sold in pairs
- Standard finishes: ZN, GRN, HDG
- Wt./C 100 Lbs. (45.3 kg)

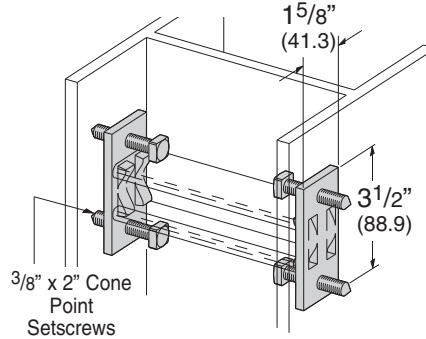

B613A COLUMN SUPPORT FOR B52

- Design Load 800 Lbs. (3.56 kN) Slip with Safety Factor of 3
- Use with B52 and B54 Channel
- Setscrews to be torqued to 19 ft./Lbs
- Sold in pairs
- Standard finishes: ZN, GRN, HDG
- Wt./C 100 Lbs. (45.3 kg)

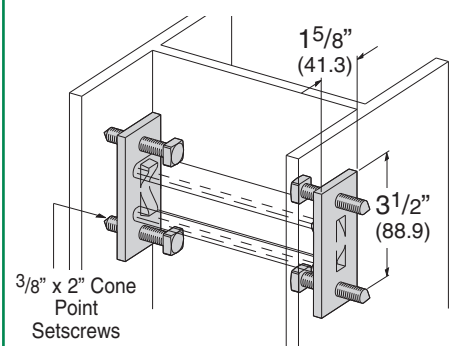

B422 SERIES RIGHT ANGLE CLAMP

- Safety Factor of 5
- Material: 7 Gauge (4.5)
- Standard finishes: ZN, SS4

Part No.	Conduit Size		A		Design Load Vertical Pull		Wt./C	
					Lbs.	kg	Lbs.	kg
B422-1/2	1/2"	(15)	2 3/8"	(60.3)	250	(1.11)	38	(17.2)
B422-3/4	3/4"	(20)	2 3/8"	(60.3)	300	(1.33)	39	(17.7)
B422-1	1"	(25)	2 7/8"	(73.0)	400	(1.78)	48	(21.8)
B422-1 1/4	1 1/4"	(32)	2 7/8"	(73.0)	400	(1.78)	50	(22.7)
B422-1 1/2	1 1/2"	(40)	3 1/4"	(82.5)	500	(2.22)	59	(26.7)
B422-2	2"	(50)	3 11/16"	(93.7)	600	(2.67)	75	(34.0)
B422-2 1/2	2 1/2"	(65)	4 1/4"	(107.9)	700	(3.11)	98	(44.4)
B422-3	3"	(80)	4 7/8"	(123.8)	800	(3.56)	111	(50.3)
B422-3 1/2	3 1/2"	(90)	5 7/16"	(138.1)	900	(4.00)	123	(55.8)
B422-4	4"	(100)	6"	(152.4)	1000	(4.45)	135	(61.2)

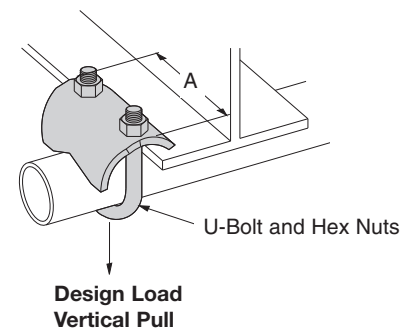

B107S U-SUPPORT

- Material: 7 Gauge (4.5)
- Standard finishes: ZN, GRN
- Wt./C 51 Lbs. (23.1 kg)

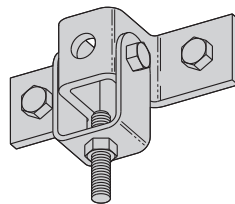
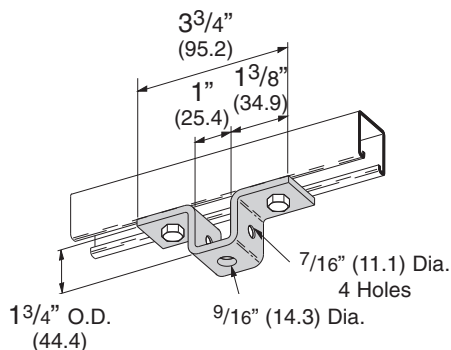

- Illustration shows B107S and B593 used together
- Design Load 900 Lbs., strength of assembly only
- Verify anchorage

B593 CLEVIS SWIVEL

- Includes:
 - 1 pc. 3/8"-16 x 2" HHCS
 - 1 pc. 3/8"-16 Hex Nut
- Material: 11 Gauge (3.0)
- Standard finishes: ZN, GRN
- Wt./C 31 Lbs. (14.0 kg)

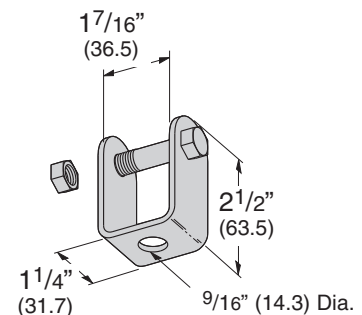

Reference page 112 for general fitting and standard finish specifications.

Pipe/Conduit Clamps & Hangers

Cooper B-Line's beam attachments and pipe supports offered in this section are designed to provide supports without drilling or welding. A complete selection of beam clamps, pipe clamps, rollers, supports and accessories are designed for use with Cooper B-Line channels and offer many installation advantages.

Materials & Finishes*

Pipe clamps, pipe hangers, beam clamps, brackets, and rollers are made from low carbon steel strips, plates or rod unless noted.

Finish Code	Finish	Specification
PLN	Plain	ASTM A1011 33,000 PSI min. yield
ZN	Electro-Plated Zinc	ASTM B633 SC3 Type III or ASTM A653
GRN	Dura-Green	
DCU	Dura-Copper	
HDG	Hot-Dipped Galvanized	ASTM A123
YZN	Yellow Zinc Chromate	ASTM B633 SC3 Type II
SS4	Stainless Steel Type 304	ASTM A240
SS6	Stainless Steel Type 316	ASTM A240
AL	Aluminum	ASTM B209

*Unless otherwise noted.

Load Data

The load data published includes a safety factor of 5.0 unless noted (safety factor = ratio of ultimate load to the design load).

Recommended Torque For Setscrews (unless noted)

Setscrew Size	1/4"-20	3/8"-16	1/2"-13
Foot/Lbs.	4	5	11
Nm	5	7	15

Setscrew Size	5/8"-11	3/4"-10
Foot/Lbs.	21	34
Nm	28	46

*See chart on page 72 for bolt torque.

Metric

Metric dimensions are shown in parentheses. Unless noted, all metric dimensions are in millimeters.



B2207 THRU B2213 MULTI-GRIP PIPE CLAMPS FOR THINWALL (EMT), I.M.C., RIGID CONDUIT OR PIPE

- Safety Factor of 5
- Add PA to suffix for pre-assembled pipe clamps
- Includes Combination Recess Hex Head Machine Screw and Square Nut
- Material: ASTM A1011 33,000 PSI min. yield
- Standard finish: ZN

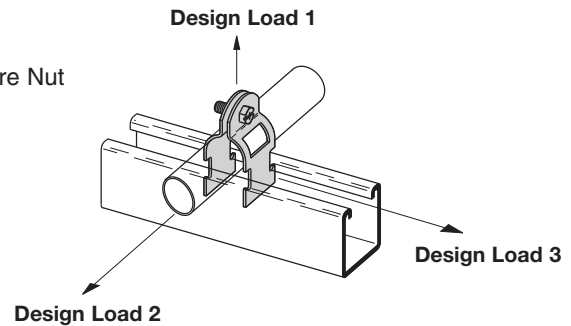

Part No.	Nominal Size		Material Thickness		O.D. Size Range		Alternate For Clamp No.'s	Design Load 1		Design Load 2		Design Load 3		Wt./C	
								Lbs.	kN	Lbs.	kg	Lbs.	kg	Lbs.	kg
B2207	3/8"	(10)	16 Ga.	(1.5)	.557-.706	(14.2-17.9)	B2000, B2001, B2026	400	(1.78)	50	(.22)	50	(.22)	9	(4.1)
B2208	1/2"	(15)	16 Ga.	(1.5)	.701-.875	(17.8-22.2)	B2001, B2008, B2027, B2028	400	(1.78)	50	(.22)	50	(.22)	11	(5.0)
B2209	3/4"	(20)	14 Ga.	(1.9)	.917-1.081	(23.2-27.4)	B2002, B2009, B2029	400	(1.78)	50	(.22)	50	(.22)	12	(5.4)
B2210	1"	(25)	14 Ga.	(1.9)	1.125-1.375	(28.6-34.9)	B2003, B2010, B2030, B2031, B2032	400	(1.78)	50	(.22)	50	(.22)	13	(5.9)
B2211	1 1/4"	(32)	14 Ga.	(1.9)	1.500-1.691	(38.1-42.9)	B2004, B2011, B2033, B2034	400	(1.78)	50	(.22)	50	(.22)	15	(6.8)
B2212	1 1/2"	(40)	12 Ga.	(2.6)	1.735-1.931	(44.0-49.0)	B2005, B2012, B2035, B2036	600	(2.67)	75	(.33)	75	(.33)	23	(10.4)
B2213	2"	(50)	12 Ga.	(2.6)	2.192-2.400	(55.7-60.9)	B2006, B2013 B2039	600	(2.67)	75	(.33)	75	(.33)	26	(11.8)

Pipe/Conduit Clamps & Hangers

BPC-8 THRU BPC-64 BREAK-APART CONDUIT CLAMP

- Design Load 200 Lbs. (.896 kN)
- Includes Combination Recess Hex Head Machine Screw
- Material: ASTM A1011 33,000 PSI min. yield
- Standard finish: ZN

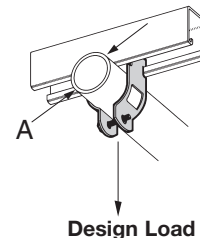

Part No.	A		Wt./C	
	Rigid or EMT Conduit Size		Lbs.	kg
BPC-8	1/2"	(21.3)	11.2	(5.1)
BPC-12	3/4"	(26.7)	12.7	(5.8)
BPC-16	1"	(33.4)	14.5	(6.6)
BPC-20	1 1/4"	(42.2)	16.5	(7.5)
BPC-24	1 1/2"	(48.3)	18.5	(8.4)
BPC-32	2"	(60.3)	21.5	(9.8)
BPC-40	2 1/2"	(73.0)	21.5	(9.8)
BPC-48	3"	(88.9)	22.0	(10.0)
BPC-56	3 1/2"	(101.6)	23.0	(10.4)
BPC-64	4"	(114.3)	27.5	(12.5)

Reference page 126 for general fitting and standard finish specifications.

Pipe Clamps

B2000 SERIES PIPE AND CONDUIT CLAMPS

- Safety Factor of 5
- Add PA to suffix for pre-assembled pipe clamps
- Includes Combination Recess Hex Head Machine Screw and Square Nut
- Material: 16 Ga. (1.5), 14 Ga. (1.9), 12 Ga. (2.6) ASTM A1011 33,000 PSI min. yield and 11 Ga. (3.0) ASTM A1011HSLA Gr. 50
- Standard finishes: ZN, HDG, SS4, SS6, AL

Note: For EMT sizes 2¹/₂" and larger use rigid conduit sizes.

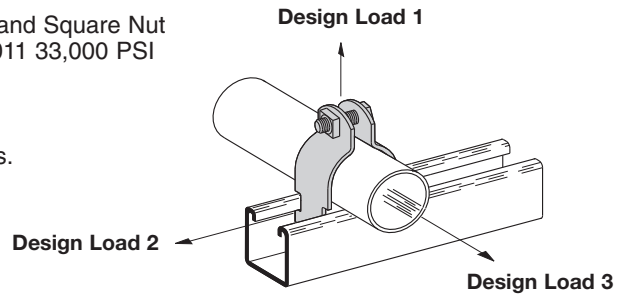

THINWALL CONDUIT (EMT) CLAMPS

Part No.	Conduit Size		Material Thickness		Design Load 1		Design Load 2		Design Load 3		Wt./C	
					Lbs.	kN	Lbs.	kg	Lbs.	kg	Lbs.	kg
B2000	3/8"	(10)	16 Ga.	(1.5)	400	(1.78)	50	(.22)	50	(.22)	10	(4.5)
B2001	1/2"	(15)	16 Ga.	(1.5)	400	(1.78)	50	(.22)	50	(.22)	10	(4.5)
B2002	3/4"	(20)	16 Ga.	(1.9)	400	(1.78)	50	(.22)	50	(.22)	11	(5.0)
B2003	1"	(25)	14 Ga.	(1.9)	600	(2.67)	75	(.33)	75	(.33)	16	(7.2)
B2004	1 1/4"	(32)	14 Ga.	(1.9)	600	(2.67)	75	(.33)	75	(.33)	19	(8.6)
B2005	1 1/2"	(40)	12 Ga.	(2.6)	800	(3.56)	125	(.56)	125	(.56)	28	(12.7)
B2006	2"	(50)	12 Ga.	(2.6)	800	(3.56)	125	(.56)	125	(.56)	33	(14.9)

RIGID CONDUIT OR PIPE CLAMPS

Part No.	Conduit Size		Material Thickness		Design Load 1		Design Load 2		Design Load 3		Wt./C	
					Lbs.	kN	Lbs.	kg	Lbs.	kg	Lbs.	kg
B2001	3/8"	(10)	16 Ga.	(1.5)	400	(1.78)	50	(.22)	50	(.22)	10	(4.5)
B2008	1/2"	(15)	16 Ga.	(1.5)	400	(1.78)	50	(.22)	50	(.22)	11	(5.0)
B2009	3/4"	(20)	14 Ga.	(1.9)	600	(2.67)	75	(.33)	75	(.33)	15	(6.8)
B2010	1"	(25)	14 Ga.	(1.9)	600	(2.67)	75	(.33)	75	(.33)	16	(7.2)
B2011	1 1/4"	(32)	14 Ga.	(1.9)	600	(2.67)	75	(.33)	75	(.33)	20	(9.1)
B2012	1 1/2"	(40)	12 Ga.	(2.6)	800	(3.56)	125	(.56)	125	(.56)	30	(13.6)
B2013	2"	(50)	12 Ga.	(2.6)	800	(3.56)	125	(.56)	125	(.56)	34	(15.4)
B2014	2 1/2"	(65)	12 Ga.	(2.6)	800	(3.56)	125	(.56)	125	(.56)	38	(17.2)
B2015	3"	(80)	12 Ga.	(2.6)	800	(3.56)	125	(.56)	125	(.56)	44	(19.9)
B2016	3 1/2"	(90)	11 Ga.	(3.0)	1000	(4.45)	200	(.89)	150	(.67)	61	(27.6)
B2017	4"	(100)	11 Ga.	(3.0)	1000	(4.45)	200	(.89)	150	(.67)	66	(29.9)
B2018	4 1/2"	(115)	11 Ga.	(3.0)	1000	(4.45)	200	(.89)	150	(.67)	70	(31.7)
B2019	5"	(125)	11 Ga.	(3.0)	1000	(4.45)	200	(.89)	150	(.67)	77	(34.9)
B2020	6"	(150)	11 Ga.	(3.0)	1000	(4.45)	200	(.89)	150	(.67)	100	(45.3)
B2021	7"	(175)	11 Ga.	(3.0)	1000	(4.45)	250	(1.11)	200	(.89)	115	(52.1)
B2022	8"	(200)	11 Ga.	(3.0)	1000	(4.45)	250	(1.11)	200	(.89)	128	(58.0)
B2130	10"	(254)	11 Ga.	(3.0)	1000	(4.45)	250	(1.11)	200	(.89)	160	(72.6)
B2132	12"	(305)	11 Ga.	(3.0)	1000	(4.45)	250	(1.11)	200	(.89)	185	(83.9)

Reference page 126 for general fitting and standard finish specifications.

B2000 SERIES PVC CLAMPS

- Safety Factor of 5
- Add PA to suffix for pre-assembled pipe clamps
- Includes Combination Recess Hex Head Machine Screw and Square Nut
- Material: 16 Ga. (1.5), 14 Ga. (1.9), 12 Ga. (2.6) ASTM A1011 33,000 PSI min. yield and 11 Ga. (3.0) ASTM A1011HSLA Gr. 50
- Standard finishes: PVC

CLAMP SIZING CHART FOR PVC COATED RIGID CONDUIT AND CLAMPS

Nominal Conduit Size		Conduit Coating			
		.020 (.51mm)		.040 (1.01mm)	
		Clamp Coating		Clamp Coating	
		0	.020 (.51mm)	0	.020 (.51mm)
1/2"	(15)	B2008	B2002	B2002	B2029
3/4"	(20)	B2030	B2030	B2030	B2003
1"	(25)	B2032	B2032	B2032	B2004
1 1/4"	(32)	B2005	B2005	B2005	B2005
1 1/2"	(40)	B2012	B2037	B2037	B2037
2"	(50)	B2013	B2041	B2041	B2041
2 1/2"	(65)	B2014	B2045	B2045	B2045
3"	(80)	B2015	B2050	B2050	B2050
3 1/2"	(90)	B2016	B2054	B2054	B2054
4"	(100)	B2017	B2058	B2058	B2058
5"	(125)	B2019	B2066	B2066	B2066
6"	(150)	B2020	B2115	B2115	B2115

*See B2000 O.D. pipe and conduit clamp chart on pgs. 130-131 for corresponding clamp load data.

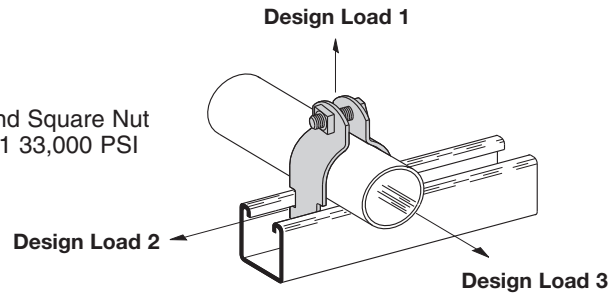

CLAMP SIZING CHART FOR PVC COATED THINWALL (EMT) CONDUIT AND CLAMPS

Nominal Conduit Size		Conduit Coating			
		.020 (.51mm)		.040 (1.01mm)	
		Clamp Coating		Clamp Coating	
		0	.020 (.51mm)	0	.020 (.51mm)
3/8"	(10)	B2026	B2026	B2026	B2001
1/2"	(15)	B2027	B2027	B2027	B2008
3/4"	(20)	B2029	B2029	B2029	B2009
1"	(25)	B2003	B2031	B2031	B2031
1 1/4"	(32)	B2004	B2011	B2011	B2011
1 1/2"	(40)	B2005	B2005	B2005	B2036
2"	(50)	B2039	B2039	B2039	B2013

*See B2000 O.D. pipe and conduit clamp chart on pgs. 130-131 for corresponding clamp load data.

B2000 SERIES COPPER TUBING CLAMPS

- Safety Factor of 5
- Add PA to suffix for pre-assembled pipe clamps
- Includes Combination Recess Hex Head Machine Screw and Square Nut
- Material: 16 Ga. (1.5), 14 Ga. (1.9), 12 Ga. (2.6) ASTM A1011 33,000 PSI min. yield and 11 Ga. (3.0) ASTM A1011HSLA Gr. 50
- Standard finish: Exclusive Dura-Copper™ Finish (DCU)

COPPER TUBING CLAMPS

Part No.	Tubing Size	O.D. Size In. (mm)	Material Thickness	Design Load 1		Design Load 2		Design Load 3		Wt./C	
				Lbs.	kN	Lbs.	kg	Lbs.	kg	Lbs.	kg
B2024DCU	1/4"	.375 (9.5)	16 Ga. (1.5)	400	(1.78)	50	(.22)	50	(.22)	8	(3.6)
B2025DCU	3/8"	.500 (12.7)	16 Ga. (1.5)	400	(1.78)	50	(.22)	50	(.22)	9	(4.1)
B2026DCU	1/2"	.625 (15.9)	16 Ga. (1.5)	400	(1.78)	50	(.22)	50	(.22)	10	(4.5)
B2027DCU	5/8"	.750 (19.0)	16 Ga. (1.5)	400	(1.78)	50	(.22)	50	(.22)	10	(4.5)
B2008DCU	3/4"	.875 (22.2)	16 Ga. (1.5)	400	(1.78)	50	(.22)	50	(.22)	11	(5.0)
B2030DCU	1"	1.125 (28.6)	14 Ga. (1.9)	600	(2.67)	75	(.33)	75	(.33)	15	(6.8)
B2032DCU	1 1/4"	1.375 (34.9)	14 Ga. (1.9)	600	(2.67)	75	(.33)	75	(.33)	17	(7.7)
B2011DCU	1 1/2"	1.625 (41.3)	14 Ga. (1.9)	600	(2.67)	75	(.33)	75	(.33)	19	(8.6)
B2038DCU	2	2.125 (54.0)	12 Ga. (2.6)	800	(3.56)	125	(.56)	125	(.56)	32	(14.5)
B2042DCU	2 1/2"	2.625 (66.7)	12 Ga. (2.6)	800	(3.56)	125	(.56)	125	(.56)	35	(15.9)
B2046DCU	3	3.125 (79.4)	12 Ga. (2.6)	800	(3.56)	125	(.56)	125	(.56)	39	(17.7)
B2050DCU	3 1/2"	3.625 (92.1)	11 Ga. (3.0)	1000	(4.45)	200	(.89)	150	(.67)	54	(24.5)
B2054DCU	4	4.125 (104.8)	11 Ga. (3.0)	1000	(4.45)	200	(.89)	150	(.67)	61	(27.6)
B2062DCU	5	5.125 (130.2)	11 Ga. (3.0)	1000	(4.45)	200	(.89)	150	(.67)	70	(31.7)
B2110DCU	6	6.125 (155.6)	11 Ga. (3.0)	1000	(4.45)	250	(1.11)	200	(.89)	94	(42.6)
B2126DCU	8	8.125 (206.4)	11 Ga. (3.0)	1000	(4.45)	250	(1.11)	200	(.89)	123	(55.8)

Reference page 126 for general fitting and standard finish specifications.

Pipe Clamps

B2000 SERIES O.D. PIPE AND CONDUIT CLAMPS

- Safety Factor of 5
- Add PA to suffix for pre-assembled pipe clamps
- Other sizes available upon request
- Includes Combination Recess Hex Head Machine Screw and Square Nut.
- Material: 16 Ga. (1.5), 14 Ga. (1.9), 12 Ga. (2.6)
ASTM A1011 33,000 PSI min. yield and 11 Ga. (3.0)
ASTM A1011HSLA Gr. 50
- Standard finishes: ZN, HDG, SS4

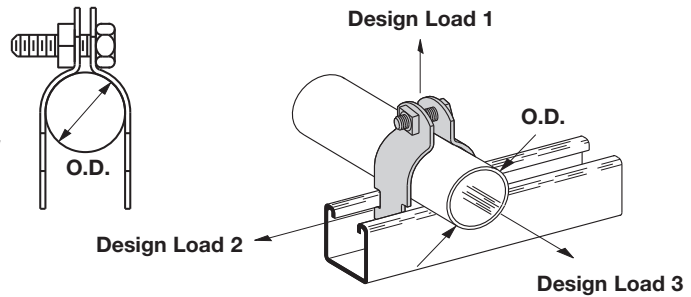

O.D. CLAMPS

Part No.	O.D. Size (in.)		Hardware Size	Material Gauge Thickness		Design Load 1		Design Load 2		Design Load 3		Wt./C	
						Lbs.	kN	Lbs.	kN	Lbs.	kN	Lbs.	kg
B2023	1/4"	(6.3)	1/4"-20	16	(1.5)	120	(.54)	30	(.13)	30	(.13)	8	(3.6)
B2024	3/8"	(9.5)	1/4"-20	16	(1.5)	300	(1.33)	40	(.18)	40	(.18)	8	(3.6)
B2025	1/2"	(12.7)	1/4"-20	16	(1.5)	400	(1.78)	50	(.22)	50	(.22)	9	(4.1)
B2026	5/8"	(15.9)	1/4"-20	16	(1.5)	400	(1.78)	50	(.22)	50	(.22)	10	(4.5)
B2027	3/4"	(19.0)	1/4"-20	16	(1.5)	400	(1.78)	50	(.22)	50	(.22)	10	(4.5)
B2008	7/8"	(22.2)	1/4"-20	16	(1.5)	400	(1.78)	50	(.22)	50	(.22)	11	(5.0)
B2029	1"	(25.4)	1/4"-20	14	(1.9)	500	(2.22)	75	(.33)	75	(.33)	15	(6.8)
B2030	1 1/8"	(28.6)	1/4"-20	14	(1.9)	600	(2.67)	75	(.33)	75	(.33)	15	(6.8)
B2031	1 1/4"	(31.7)	1/4"-20	14	(1.9)	600	(2.67)	75	(.33)	75	(.33)	16	(7.3)
B2032	1 3/8"	(34.9)	1/4"-20	14	(1.9)	600	(2.67)	75	(.33)	75	(.33)	17	(7.7)
B2004	1 1/2"	(38.1)	1/4"-20	14	(1.9)	600	(2.67)	75	(.33)	75	(.33)	18	(8.2)
B2011	1 5/8"	(41.3)	1/4"-20	14	(1.9)	600	(2.67)	75	(.33)	75	(.33)	19	(8.6)
B2005	1 3/4"	(44.4)	5/16"-18	12	(2.6)	800	(3.56)	125	(.56)	125	(.56)	29	(13.1)
B2036	1 7/8"	(47.6)	5/16"-18	12	(2.6)	800	(3.56)	125	(.56)	125	(.56)	30	(13.6)
B2037	2	(50.8)	5/16"-18	12	(2.6)	800	(3.56)	125	(.56)	125	(.56)	30	(13.6)
B2038	2 1/8"	(54.0)	5/16"-18	12	(2.6)	800	(3.56)	125	(.56)	125	(.56)	32	(14.5)
B2039	2 1/4"	(57.1)	5/16"-18	12	(2.6)	800	(3.56)	125	(.56)	125	(.56)	32	(14.5)
B2013	2 3/8"	(60.3)	5/16"-18	12	(2.6)	800	(3.56)	125	(.56)	125	(.56)	34	(15.4)
B2041	2 1/2"	(63.5)	5/16"-18	12	(2.6)	800	(3.56)	125	(.56)	125	(.56)	35	(15.9)
B2042	2 5/8"	(66.7)	5/16"-18	12	(2.6)	800	(3.56)	125	(.56)	125	(.56)	35	(15.9)
B2043	2 3/4"	(69.8)	5/16"-18	12	(2.6)	800	(3.56)	125	(.56)	125	(.56)	38	(17.2)
B2014	2 7/8"	(73.0)	5/16"-18	12	(2.6)	800	(3.56)	125	(.56)	125	(.56)	38	(17.2)
B2045	3	(76.2)	5/16"-18	12	(2.6)	800	(3.56)	125	(.56)	125	(.56)	38	(17.2)
B2046	3 1/8"	(79.4)	5/16"-18	12	(2.6)	800	(3.56)	125	(.56)	125	(.56)	39	(17.7)
B2047	3 1/4"	(82.5)	5/16"-18	12	(2.6)	800	(3.56)	125	(.56)	125	(.56)	41	(18.6)
B2048	3 3/8"	(85.7)	5/16"-18	12	(2.6)	800	(3.56)	125	(.56)	125	(.56)	43	(19.5)
B2015	3 1/2"	(88.9)	5/16"-18	12	(2.6)	800	(3.56)	125	(.56)	125	(.56)	44	(20.0)
B2050	3 5/8"	(92.1)	5/16"-18	11	(3.0)	1000	(4.45)	200	(.89)	150	(.67)	54	(24.5)
B2051	3 3/4"	(95.2)	5/16"-18	11	(3.0)	1000	(4.45)	200	(.89)	150	(.67)	57	(25.8)
B2052	3 7/8"	(98.4)	5/16"-18	11	(3.0)	1000	(4.45)	200	(.89)	150	(.67)	55	(25.0)
B2016	4	(101.6)	5/16"-18	11	(3.0)	1000	(4.45)	200	(.89)	150	(.67)	57	(25.8)
B2054	4 1/8"	(104.8)	5/16"-18	11	(3.0)	1000	(4.45)	200	(.89)	150	(.67)	61	(27.7)
B2055	4 1/4"	(107.9)	5/16"-18	11	(3.0)	1000	(4.45)	200	(.89)	150	(.67)	62	(28.1)
B2056	4 3/8"	(111.1)	5/16"-18	11	(3.0)	1000	(4.45)	200	(.89)	150	(.67)	64	(29.0)
B2017	4 1/2"	(114.3)	5/16"-18	11	(3.0)	1000	(4.45)	200	(.89)	150	(.67)	66	(29.9)
B2058	4 5/8"	(117.5)	5/16"-18	11	(3.0)	1000	(4.45)	200	(.89)	150	(.67)	66	(29.9)

Reference page 126 for general fitting and standard finish specifications.

B2000 SERIES O.D. PIPE AND CONDUIT CLAMPS

- Safety Factor of 5
- Add PA to suffix for pre-assembled pipe clamps
- Other sizes available upon request
- Includes Combination Recess Hex Head Machine Screw and Square Nut.
- Material: 16 Ga. (1.5), 14 Ga. (1.9), 12 Ga. (2.6) ASTM A1011 33,000 PSI min. yield and 11 Ga. (3.0) ASTM A1011HSLA Gr. 50
- Standard finishes: ZN, HDG, SS4

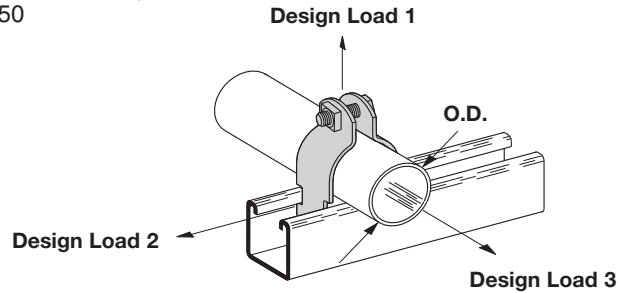

O.D. CLAMPS

Part No.	O.D. Size (in.)		Hardware Size	Material Gauge Thickness		Design Load 1		Design Load 2		Design Load 3		Wt./C	
						Lbs.	kN	Lbs.	kN	Lbs.	kN	Lbs.	kg
B2059	4 ³ / ₄ "	(120.6)	5/16"-18	11	(3.0)	1000	(4.45)	200	(.89)	150	(.67)	68	(30.8)
B2060	4 ⁷ / ₈ "	(123.8)	5/16"-18	11	(3.0)	1000	(4.45)	200	(.89)	150	(.67)	69	(31.3)
B2018	5	(127.0)	5/16"-18	11	(3.0)	1000	(4.45)	200	(.89)	150	(.67)	70	(31.8)
B2062	5 ¹ / ₈ "	(130.2)	5/16"-18	11	(3.0)	1000	(4.45)	200	(.89)	150	(.67)	70	(31.8)
B2063	5 ¹ / ₄ "	(133.3)	5/16"-18	11	(3.0)	1000	(4.45)	200	(.89)	150	(.67)	70	(31.8)
B2064	5 ³ / ₈ "	(136.5)	5/16"-18	11	(3.0)	1000	(4.45)	200	(.89)	150	(.67)	77	(34.9)
B2019	5 ¹ / ₂ "	(139.7)	5/16"-18	11	(3.0)	1000	(4.45)	200	(.89)	150	(.67)	78	(35.4)
B2066	5 ⁵ / ₈ "	(142.9)	5/16"-18	11	(3.0)	1000	(4.45)	200	(.89)	150	(.67)	83	(37.6)
B2067	5 ³ / ₄ "	(146.0)	5/16"-18	11	(3.0)	1000	(4.45)	200	(.89)	150	(.67)	84	(38.1)
B2068	5 ⁷ / ₈ "	(149.2)	5/16"-18	11	(3.0)	1000	(4.45)	200	(.89)	150	(.67)	85	(38.6)
B2069	6"	(152.4)	5/16"-18	11	(3.0)	1000	(4.45)	200	(.89)	150	(.67)	87	(39.5)
B2110	6 ¹ / ₈ "	(155.6)	3/8"-16	11	(3.0)	1000	(4.45)	250	(1.11)	200	(.89)	94	(42.6)
B2111	6 ¹ / ₄ "	(158.7)	3/8"-16	11	(3.0)	1000	(4.45)	250	(1.11)	200	(.89)	96	(43.5)
B2112	6 ³ / ₈ "	(161.9)	3/8"-16	11	(3.0)	1000	(4.45)	250	(1.11)	200	(.89)	98	(44.4)
B2113	6 ¹ / ₂ "	(165.1)	3/8"-16	11	(3.0)	1000	(4.45)	250	(1.11)	200	(.89)	99	(44.9)
B2020	6 ⁵ / ₈ "	(168.3)	3/8"-16	11	(3.0)	1000	(4.45)	250	(1.11)	200	(.89)	100	(45.4)
B2115	6 ³ / ₄ "	(171.4)	3/8"-16	11	(3.0)	1000	(4.45)	250	(1.11)	200	(.89)	102	(46.3)
B2116	6 ⁷ / ₈ "	(174.6)	3/8"-16	11	(3.0)	1000	(4.45)	250	(1.11)	200	(.89)	104	(47.2)
B2117	7"	(177.8)	3/8"-16	11	(3.0)	1000	(4.45)	250	(1.11)	200	(.89)	106	(48.1)
B2118	7 ¹ / ₈ "	(181.0)	3/8"-16	11	(3.0)	1000	(4.45)	250	(1.11)	200	(.89)	108	(49.0)
B2119	7 ¹ / ₄ "	(184.1)	3/8"-16	11	(3.0)	1000	(4.45)	250	(1.11)	200	(.89)	110	(49.9)
B2120	7 ³ / ₈ "	(187.3)	3/8"-16	11	(3.0)	1000	(4.45)	250	(1.11)	200	(.89)	112	(50.8)
B2121	7 ¹ / ₂ "	(190.5)	3/8"-16	11	(3.0)	1000	(4.45)	250	(1.11)	200	(.89)	114	(51.7)
B2021	7 ⁵ / ₈ "	(193.7)	3/8"-16	11	(3.0)	1000	(4.45)	250	(1.11)	200	(.89)	115	(52.2)
B2123	7 ³ / ₄ "	(196.8)	3/8"-16	11	(3.0)	1000	(4.45)	250	(1.11)	200	(.89)	117	(53.1)
B2124	7 ⁷ / ₈ "	(200.0)	3/8"-16	11	(3.0)	1000	(4.45)	250	(1.11)	200	(.89)	119	(54.0)
B2125	8"	(203.2)	3/8"-16	11	(3.0)	1000	(4.45)	250	(1.11)	200	(.89)	121	(54.9)
B2126	8 ¹ / ₈ "	(206.4)	3/8"-16	11	(3.0)	1000	(4.45)	250	(1.11)	200	(.89)	123	(55.8)
B2127	8 ¹ / ₄ "	(209.5)	3/8"-16	11	(3.0)	1000	(4.45)	250	(1.11)	200	(.89)	125	(56.7)
B2128	8 ³ / ₈ "	(212.7)	3/8"-16	11	(3.0)	1000	(4.45)	250	(1.11)	200	(.89)	126	(57.2)
B2129	8 ¹ / ₂ "	(215.9)	3/8"-16	11	(3.0)	1000	(4.45)	250	(1.11)	200	(.89)	128	(58.1)
B2022	8 ⁵ / ₈ "	(219.1)	3/8"-16	11	(3.0)	1000	(4.45)	250	(1.11)	200	(.89)	128	(58.1)
B2130	10 ³ / ₄ "	(273.0)	3/8"-16	11	(3.0)	1000	(4.45)	250	(1.11)	200	(.89)	160	(72.6)
B2132	12 ³ / ₄ "	(323.8)	3/8"-16	11	(3.0)	1000	(4.45)	250	(1.11)	200	(.89)	185	(83.9)

Reference page 126 for general fitting and standard finish specifications.

Pipe Clamps

B1508 THRU B1564S CONDUIT/STRUT CLAMPS

- Safety Factor of 3
- Clamps without saddles are not recommended for flexible conduit or cable
- All Sizes Include:
1/4"-20 Slotted Hex Head Machine Screw
- Standard finish: ZN

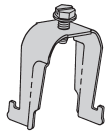
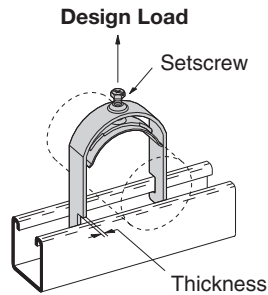

B1508 THRU B1520

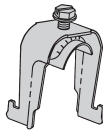

B1508S THRU B1524S

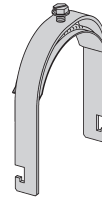

B1532S THRU B1564S

Part No.	Use With				Thickness		Design Load		Wt./C	
	EMT		Rigid Conduit				Lbs.	kN	Lbs.	kg
B1508	1/2"	(15)	—	—	16 Ga.	(1.5)	200	(.89)	7.4	(3.4)
B1512	3/4"	(20)	1/2"	(15)	16 Ga.	(1.5)	200	(.89)	8.0	(3.6)
B1516	1"	(25)	3/4"	(20)	14 Ga.	(1.9)	300	(1.33)	11.0	(5.0)
B1520	1 1/4"	(32)	1"	(25)	14 Ga.	(1.9)	300	(1.33)	12.5	(5.7)
B1508S	1/2"	(15)	—	—	16 Ga.	(1.5)	200	(.89)	8.6	(3.9)
B1512S	3/4"	(20)	1/2"	(15)	16 Ga.	(1.5)	200	(.89)	9.2	(4.2)
B1516S	1"	(25)	3/4"	(20)	14 Ga.	(1.9)	300	(1.33)	12.7	(5.8)
B1520S	1 1/4"	(32)	1"	(25)	14 Ga.	(1.9)	300	(1.33)	14.6	(6.6)
B1524S	1 1/2"	(40)	1 1/4"	(32)	12 Ga.	(2.6)	400	(1.78)	20.5	(9.3)
B1532S	2"	(50)	1 1/2"	(40)	12 Ga.	(2.6)	400	(1.78)	21.5	(9.8)
B1534S	—	—	2"	(50)	12 Ga.	(2.6)	400	(1.78)	22.7	(10.3)
B1540S	2 1/2"	(65)	2 1/2"	(65)	12 Ga.	(2.6)	400	(1.78)	26.0	(11.9)
B1548S	3"	(80)	3"	(80)	12 Ga.	(2.6)	400	(1.78)	30.2	(13.7)
B1556S	3 1/2"	(90)	3 1/2"	(90)	12 Ga.	(2.6)	400	(1.78)	33.3	(15.1)
B1564S	4"	(100)	4"	(100)	12 Ga.	(2.6)	400	(1.78)	36.6	(16.6)

Reference page 126 for general fitting and standard finish specifications.

B2601 THRU B2610 TWIST EAR® PIPE CLAMP

- One piece break apart, screw retainer, thread impressions
- Tighter alignment, no need to leave additional space between clamps in order to access nut and bolt
- Easier access bolt can be tightened directly from front
- Available in 1/2", 3/4", 1" rigid and EMT Conduit
- Recommended Torque 30 in. - lbs.
- Safety Factor of 3
- Standard finish: ZN

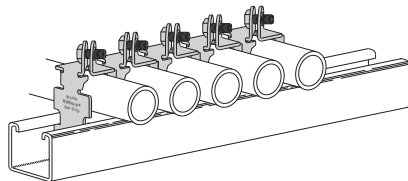

Allows for multiple clamps to be used in succession, with easier access than other pipe clamps.

Design Load

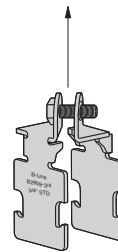

Break-apart - break in the middle, bolt the ends together.

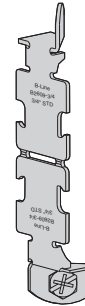

No loose pieces. One piece break apart with screw retainer and thread impressions.

Part No.	Use With		Thickness	Design Load		Wt./C	
	EMT	Rigid Conduit		Lbs.	kN	Lbs.	kg
B2601	1/2" (17.9)	—	16 Ga.	300	(1.34)	8.2	(3.7)
B2602	3/4" (23.4)	—	14 Ga.	500	(2.24)	13.5	(6.1)
B2603	1" (29.5)	—	14 Ga.	500	(2.24)	15.6	(7.1)
B2608	—	1/2" (21.3)	16 Ga.	300	(1.34)	8.2	(3.7)
B2609	—	3/4" (26.7)	14 Ga.	500	(2.24)	13.5	(6.1)
B2610	—	1" (33.4)	14 Ga.	500	(2.24)	15.6	(7.1)

BP081SS THRU BP475SS P CLAMPS

- Minimizes induction heating
- Material: Stainless Steel Type 304

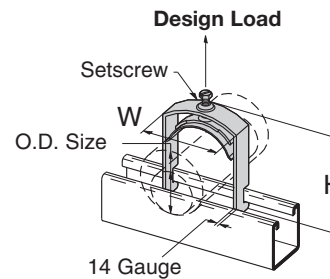

Part No.	O.D. Size		Height H		Width W		Design Load		Wt./C.	
	In.	mm	In.	mm	In.	mm	Lbs.	kN	Lbs.	kg
BP081SS	.250-.840	(6.4-21.3)	1.86	(47.2)	0.87	(22.1)	300	(1.33)	9.0	(4.1)
BP110SS	.810-1.100	(20.6-28.0)	2.18	(55.4)	1.19	(30.2)	300	(1.33)	12.0	(5.4)
BP135SS	.850-1.350	(21.6-34.8)	2.25	(57.2)	1.38	(35.1)	300	(1.33)	14.0	(6.3)
BP175SS	1.250-1.750	(31.8-44.4)	2.78	(70.6)	1.78	(45.2)	300	(1.33)	21.0	(9.5)
BP205SS	1.550-2.050	(39.4-52.1)	3.00	(76.2)	2.28	(57.9)	300	(1.33)	30.0	(13.6)
BP250SS	2.00-2.50	(50.8-63.5)	3.43	(87.1)	2.83	(71.9)	300	(1.33)	35.0	(15.9)
BP300SS	2.55-3.00	(64.7-76.2)	3.87	(97.8)	3.15	(80.0)	300	(1.33)	39.0	(17.7)
BP325SS	2.75-3.25	(69.9-82.8)	4.06	(103.1)	3.28	(83.3)	300	(1.33)	41.0	(18.6)
BP375SS	3.25-3.75	(82.6-95.3)	4.60	(116.8)	3.83	(97.3)	300	(1.33)	47.0	(21.3)
BP425SS	3.75-4.25	(95.3-108.0)	5.13	(130.3)	4.50	(114.3)	300	(1.33)	54.0	(24.4)
BP475SS	4.25-4.75	(108.0-120.7)	5.70	(144.8)	4.85	(123.2)	300	(1.33)	58.0	(26.3)

Reference page 126 for general fitting and standard finish specifications.

VibraClamp™ Pipe Clamps

BVT SERIES VIBRACLAMPS-COPPER & O.D.

- Safety Factor of 3
- Accesses tubing sizes 1/8" (3) to 6" (150)
- Allows easy one tool installation
- Endures both high (+300°F) and low (-40°F) temperatures
- Dampens vibration and noise
- Eliminates galvanic metal to metal contact
- Resists most industrial oils and solvents
- Reduces thermal loss and gain
- Secures tubing firmly to channel (strut)
- Dielectric strength of 400 volts/mil
- Includes cushion, clamp, screw and nut
- Standard finishes: YZN, SS4

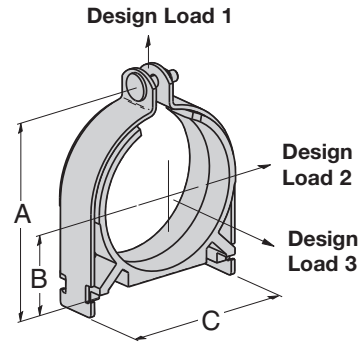

Catalog Number	Tubing O.D. Size		Copper Tubing Size		Dimensions						Wt./C	
					A	B	C				Lbs.	kg
BVT025	1/4"	(6.3)	1/8"	(3)	1.22	(30.9)	0.19	(4.8)	0.49	(12.4)	11	(5.0)
BVT037	3/8"	(9.5)	1/4"	(6)	1.36	(34.5)	0.25	(6.3)	0.61	(15.5)	12	(5.4)
BVT050	1/2"	(12.7)	3/8"	(10)	1.49	(37.8)	0.31	(7.8)	0.74	(18.8)	14	(6.3)
BVT062	5/8"	(15.9)	1/2"	(15)	1.62	(41.1)	0.38	(9.6)	0.86	(21.8)	15	(6.8)
BVT075	3/4"	(19.0)	5/8"	(17)	1.87	(47.4)	0.50	(12.7)	1.15	(29.2)	19	(8.6)
BVT087	7/8"	(22.2)	3/4"	(20)	2.00	(50.8)	0.56	(14.2)	1.27	(32.2)	21	(9.5)
BVT100	1"	(25.4)	—	—	2.25	(57.1)	0.69	(17.5)	1.52	(38.6)	22	(10.0)
BVT112	1 1/8"	(28.6)	1"	(25)	2.25	(57.1)	0.69	(17.5)	1.52	(38.6)	26	(11.8)
BVT125	1 1/4"	(31.7)	—	—	2.51	(63.7)	0.81	(20.6)	1.78	(45.2)	36	(16.3)
BVT137	1 3/8"	(34.9)	1 1/4"	(32)	2.51	(63.7)	0.81	(20.6)	1.78	(45.2)	38	(17.2)
BVT150	1 1/2"	(38.1)	—	—	2.74	(69.6)	0.88	(22.4)	1.96	(49.8)	35	(15.9)
BVT162	1 5/8"	(41.3)	1 1/2"	(40)	3.00	(76.2)	1.00	(25.4)	2.20	(55.9)	40	(18.1)
BVT175	1 3/4"	(44.4)	—	—	3.13	(79.5)	1.06	(26.9)	2.33	(59.1)	44	(19.9)
BVT187	1 7/8"	(47.6)	—	—	3.28	(83.3)	1.13	(28.7)	2.46	(62.5)	40	(18.1)
BVT200	2"	(50.8)	—	—	3.52	(89.4)	1.25	(31.7)	2.70	(68.6)	55	(25.0)
BVT212	2 1/8"	(54.0)	2"	(50)	3.52	(89.4)	1.25	(31.7)	2.70	(68.6)	55	(25.0)
BVT225	2 1/4"	(57.1)	—	—	3.64	(92.4)	1.31	(33.2)	2.83	(71.8)	54	(24.5)
BVT250	2 1/2"	(63.5)	—	—	3.91	(99.3)	1.43	(36.3)	3.11	(79.0)	56	(25.4)
BVT262	2 5/8"	(66.6)	2 1/2"	(65)	4.02	(102.1)	1.50	(38.1)	3.20	(81.3)	55	(25.0)
BVT300	3"	(76.2)	—	—	4.42	(112.2)	1.68	(42.6)	3.61	(91.6)	67	(30.4)
BVT312	3 1/8"	(79.4)	3"	(80)	4.53	(115.0)	1.75	(44.4)	3.70	(93.9)	64	(29.0)
BVT362	3 5/8"	(92.1)	3 1/2"	(90)	5.05	(128.2)	2.00	(50.8)	4.23	(107.4)	76	(34.5)
BVT412	4 1/8"	(104.8)	4"	(100)	5.55	(140.9)	2.25	(57.1)	4.73	(120.1)	93	(42.2)
BVT612	6 1/8"	(155.5)	6"	(150)	7.62	(193.5)	3.25	(82.5)	6.74	(171.1)	136	(61.6)

Catalog Number	Design Load 1		Design Load 2		Design Load 3	
	Lbs.	kN	Lbs.	kN	Lbs.	kN
BVT025	400	(1.78)	50	(0.22)	50	(0.22)
BVT037	400	(1.78)	50	(0.22)	50	(0.22)
BVT050	400	(1.78)	50	(0.22)	50	(0.22)
BVT062	400	(1.78)	50	(0.22)	50	(0.22)
BVT075	600	(2.67)	75	(0.33)	75	(0.33)
BVT087	600	(2.67)	75	(0.33)	75	(0.33)
BVT100	600	(2.67)	75	(0.33)	75	(0.33)
BVT112	600	(2.67)	75	(0.33)	75	(0.33)
BVT125	600	(2.67)	75	(0.33)	75	(0.33)
BVT137	600	(2.67)	75	(0.33)	75	(0.33)
BVT150	600	(2.67)	75	(0.33)	75	(0.33)
BVT162	800	(3.56)	125	(0.56)	125	(0.56)
BVT175	800	(3.56)	125	(0.56)	125	(0.56)
BVT187	800	(3.56)	125	(0.56)	125	(0.56)
BVT200	800	(3.56)	125	(0.56)	125	(0.56)
BVT212	800	(3.56)	125	(0.56)	125	(0.56)
BVT225	800	(3.56)	125	(0.56)	125	(0.56)
BVT250	800	(3.56)	125	(0.56)	125	(0.56)
BVT262	800	(3.56)	125	(0.56)	125	(0.56)
BVT300	800	(3.56)	125	(0.56)	125	(0.56)
BVT312	800	(3.56)	125	(0.56)	125	(0.56)
BVT362	1000	(4.45)	200	(0.89)	150	(0.67)
BVT412	1000	(4.45)	200	(0.89)	150	(0.67)
BVT612	1000	(4.45)	200	(0.89)	150	(0.67)

Reference page 126 for general fitting and standard finish specifications.

Pipe/Conduit Clamps & Hangers

BVP SERIES VIBRACLAMPS-IRON PIPE & RIGID CONDUIT

- Safety Factor of 3
- Accesses pipe sizes 1/4" (6) to 6" (150)
- Allows easy one tool installation
- Endures both high (+300°F) and low (-40°F) temperatures
- Dampens vibration and noise
- Eliminates galvanic metal to metal contact
- Resists most industrial oils and solvents
- Reduces thermal loss and gain
- Secures pipe firmly to channel (strut)
- Dielectric strength of 400 volts/mil
- Includes cushion, clamp, screw and nut
- Standard finishes: YZN, SS4

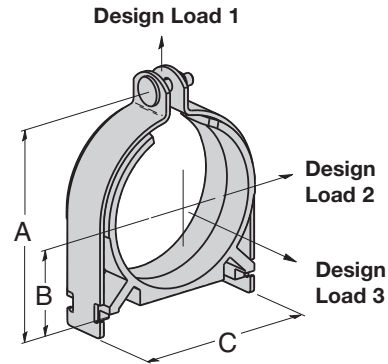

Catalog Number	Nominal Pipe Size		Steel O.D. Size		Dimensions			Wt./C				
					A	B	C	Lbs.	kg			
BVP025	1/4"	(6.3)	0.540	(13.7)	1.61	(39.9)	0.37	(9.4)	0.87	(22.1)	15	(6.8)
BVP037	3/8"	(9.5)	0.675	(17.1)	1.86	(47.2)	0.50	(12.7)	1.15	(29.2)	18	(8.2)
BVP050	1/2"	(12.7)	0.875	(22.2)	1.99	(50.5)	0.56	(14.2)	1.27	(32.3)	20	(9.1)
BVP075	3/4"	(19.0)	1.050	(26.7)	2.25	(57.1)	0.69	(17.5)	1.52	(38.6)	21	(9.5)
BVP100	1"	(25.4)	1.312	(33.3)	2.51	(63.8)	0.81	(20.6)	1.77	(45.0)	20	(9.1)
BVP125	1 1/4"	(31.7)	1.660	(42.2)	3.00	(76.2)	1.00	(25.4)	2.21	(56.1)	36	(16.3)
BVP150	1 1/2"	(38.1)	1.900	(48.3)	3.21	(83.1)	1.12	(28.4)	2.41	(62.3)	40	(18.1)
BVP200	2"	(50.8)	2.375	(60.3)	3.77	(95.8)	1.37	(34.8)	2.96	(75.2)	45	(20.4)
BVP250	2 1/2"	(63.5)	2.875	(73.0)	4.28	(108.7)	1.62	(41.1)	3.46	(87.9)	54	(24.5)
BVP300	3"	(76.2)	3.500	(88.9)	5.05	(128.3)	2.00	(50.8)	4.24	(107.7)	81	(36.7)
BVP350	3 1/2"	(88.9)	4.000	(101.6)	5.55	(140.9)	2.25	(57.1)	4.74	(120.3)	87	(39.4)
BVP400	4"	(101.6)	4.500	(114.3)	6.05	(153.7)	2.50	(63.5)	5.24	(133.1)	109	(49.4)
BVP500	5"	(127.0)	5.563	(141.3)	6.84	(173.7)	3.00	(76.2)	6.24	(158.4)	136	(61.6)
BVP600	6"	(152.4)	6.625	(168.3)	8.24	(209.3)	3.56	(90.4)	7.36	(186.9)	163	(73.8)

Catalog Number	Design Load 1		Design Load 2		Design Load 3	
	Lbs.	kN	Lbs.	kN	Lbs.	kN
BVP025	400	(1.78)	50	(0.22)	50	(0.22)
BVP037	600	(2.67)	75	(0.33)	75	(0.33)
BVP050	600	(2.67)	75	(0.33)	75	(0.33)
BVP075	600	(2.67)	75	(0.33)	75	(0.33)
BVP100	600	(2.67)	75	(0.33)	75	(0.33)
BVP125	800	(3.56)	125	(0.56)	125	(0.56)
BVP150	800	(3.56)	125	(0.56)	125	(0.56)
BVP200	800	(3.56)	125	(0.56)	125	(0.56)
BVP250	800	(3.56)	125	(0.56)	125	(0.56)
BVP300	1000	(4.45)	200	(0.89)	150	(0.67)
BVP350	1000	(4.45)	200	(0.89)	150	(0.67)
BVP400	1000	(4.45)	200	(0.89)	150	(0.67)
BVP500	1000	(4.45)	200	(0.89)	150	(0.67)
BVP600	1000	(4.45)	200	(0.89)	150	(0.67)

Reference page 126 for general fitting and standard finish specifications.

Armafix™ Clamps & Accessories

IPH SERIES INSERTS - INSERTS WITH CLAMPS

- Engineered load-bearing inserts prevents insulation compression
- Innovative insulated pipe support
- Desirable “Foam-to-Foam” Bond
- Slip Data: 45 lbs. (0.20 kN) max
- Recommended Clamp Torque: 12-15 in.-lbs. (1.3-1.7 Nm)
- Service Temperature Range
-58°F (-50°C) to +220°F (+105°C)



Insert Only



Assembly
Insert & Clamp

3/4" Wall Insulation Thickness

Assembly Part No.	Insert Only Part No.	Pipe/Copper/OD Size	Hanger Size*
IPH03834	IPH03834WO	3/8" O.D.	2"
IPH01234	IPH01234WO	1/2" O.D.	2"
IPH05834	IPH05834WO	5/8" O.D.	2"
IPH03434	IPH03434WO	3/4" O.D.	2"
IPH07834	IPH07834WO	7/8" O.D.	2 1/2"
IPH11834	IPH11834WO	3/4" IPS & 1 1/8" O.D.	2 1/2"
IPH13834	IPH13834WO	1 3/8" O.D.	3"
IPH15834	IPH15834WO	1 5/8" O.D.	3 1/2"
IPH11034	IPH11034WO	1 1/2" IPS & 1 7/8" O.D.	3 1/2"
IPH21834	IPH21834WO	2 1/8" O.D.	4"
IPH25834	IPH25834WO	2 5/8" O.D.	5"
IPH31834	IPH31834WO	3 1/8" O.D.	5"
IPH35834	IPH35834WO	3 5/8" O.D.	6"
IPH41834	IPH41834WO	4 1/8" O.D.	6"
IPH40034	IPH40034WO	4" IPS	6"
IPH50034	IPH50034WO	5" IPS	8"
IPH60034	IPH60034WO	6" IPS	10"
IPH80034	IPH80034WO	8" IPS	12"

* Recommended pipe hanger size for insulation thickness shown. (Order hanger separately)

IPH18230 ARMAFLEX® INSULATION TAPE

- 30 ft. (9.14 M) roll



Armaflex® is a registered trademark of Armacell.

1/2" Wall Insulation Thickness

Assembly Part No.	Insert Only Part No.	Pipe/Copper/OD Size	Hanger Size*
IPH03812	IPH03812WO	3/8" O.D.	1 1/4"
IPH01212	IPH01212WO	1/2" O.D.	1 1/4"
IPH05812	IPH05812WO	5/8" O.D.	1 1/2"
IPH03412	IPH03412WO	3/4" O.D.	1 1/2"
IPH07812	IPH07812WO	7/8" O.D.	2"
IPH11812	IPH11812WO	3/4" IPS & 1 1/8" O.D.	2"
IPH13812	IPH13812WO	1 3/8" O.D.	2 1/2"
IPH15812	IPH15812WO	1 5/8" O.D.	2 1/2"
IPH11012	IPH11012WO	1 1/2" IPS & 1 7/8" O.D.	3"
IPH21812	IPH21812WO	2 1/8" O.D.	3"
IPH25812	IPH25812WO	2 5/8" O.D.	3 1/2"
IPH31812	IPH31812WO	3 1/8" O.D.	4"
IPH35812	IPH35812WO	3 5/8" O.D.	5"
IPH41812	IPH41812WO	4 1/8" O.D.	6"
IPH40012	IPH40012WO	4" IPS	6"
IPH50012	IPH50012WO	5" IPS	8"
IPH60012	IPH60012WO	6" IPS	8"

* Recommended pipe hanger size for insulation thickness shown. (Order hanger separately)

1" Wall Insulation Thickness

Assembly Part No.	Insert Only Part No.	Pipe/Copper/OD Size	Hanger Size*
IPH05810	IPH05810WO	5/8" O.D.	2 1/2"
IPH03410	IPH03410WO	3/4" O.D.	2 1/2"
IPH07810	IPH07810WO	7/8" O.D.	3"
IPH11810	IPH11810WO	3/4" IPS & 1 1/8" O.D.	3"
IPH13810	IPH13810WO	1 3/8" O.D.	3 1/2"
IPH15810	IPH15810WO	1 5/8" O.D.	3 1/2"
IPH11010	IPH11010WO	1 1/2" IPS & 1 7/8" O.D.	4"
IPH21810	IPH21810WO	2 1/8" O.D.	4"
IPH25810	IPH25810WO	2 5/8" O.D.	5"
IPH31810	IPH31810WO	3 1/8" O.D.	5"
IPH35810	IPH35810WO	3 5/8" O.D.	6"
IPH41810	IPH41810WO	4 1/8" O.D.	6"
IPH40010	IPH40010WO	4" IPS	8"
IPH50010	IPH50010WO	5" IPS	8"
IPH60010	IPH60010WO	6" IPS	10"
IPH80010	IPH80010WO	8" IPS	12"

* Recommended pipe hanger size for insulation thickness shown. (Order hanger separately)

Reference page 126 for general fitting and standard finish specifications.

B1999 VIBRA CUSHION™

- Packaged 20 Ft. (6.09 m) per carton
- Ideal Isolation Material
- Inhibits Galvanic Corrosion
- Dampens Sound and Vibrations
- Service Temperature Range
-75°F (-60°C) to +375°F (+199°C)
- Wt./Carton 3.8 Lbs. (1.7 kg)

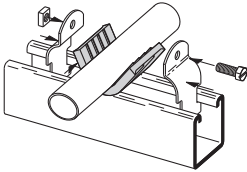

FEATURES

Vibra Cushion™ is designed for use with refrigeration lines, HVAC, copper tubing, glass pipe and hydraulic lines. It provides an energy-absorption barrier between the lines and the mounting material and remains flexible thru its entire service range of -75°F (-60°C) to +375°F (+199°C).

This elastomer allows for expansion and contraction within the mounting system and prevents galvanic reaction between dissimilar metals.

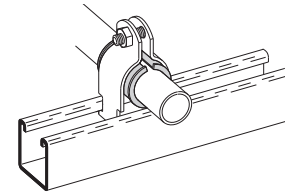

FOR RIGID CONDUIT OR IRON PIPE

Nominal Size	Length of Vibra-Cushion	Use Clamp No.
3/8"	(10) 2 1/8" (54.0)	B2002
1/2"	(15) 2 5/8" (66.7)	B2009
3/4"	(20) 3 1/4" (82.5)	B2031
1"	(25) 4 1/8" (104.8)	B2004
1 1/4"	(32) 5 3/16" (131.8)	B2012
1 1/2"	(40) 5 15/16" (150.8)	B2038
2"	(50) 7 1/2" (190.5)	B2042
2 1/2"	(65) 9" (228.6)	B2046
3"	(80) 11" (279.4)	B2051
3 1/2"	(90) 12 1/2" (317.5)	B2055
4"	(100) 14 1/2" (368.3)	B2059
5"	(125) 17 7/16" (442.9)	B2067
6"	(150) 20 3/4" (527.0)	B2116

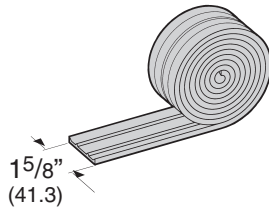

FOR THINWALL (EMT) CONDUIT

Nominal Size	Length of Vibra-Cushion	Use Clamp No.
3/8"	(10) 1 13/16" (46.0)	B2027
1/2"	(15) 2 13/16" (58.7)	B2002
3/4"	(20) 2 7/8" (73.0)	B2003
1"	(25) 3 5/8" (92.1)	B2032
1 1/4"	(32) 4 3/8" (120.6)	B2036
1 1/2"	(40) 5 7/16" (138.1)	B2012
2"	(50) 6 7/8" (174.6)	B2013

FOR COPPER TUBING TYPE L & K

Nominal Size	Length of Vibra-Cushion	Use Clamp No.
1/4"	(6) 1 3/16" (30.2)	B2026
3/8"	(10) 1 9/16" (39.7)	B2027
1/2"	(15) 1 7/8" (47.6)	B2008
5/8"	(17) 2 5/16" (58.7)	B2029
3/4"	(20) 2 3/4" (69.8)	B2030
1"	(25) 3 1/2" (88.9)	B2032
1 1/4"	(32) 4 5/16" (109.5)	B2011
1 1/2"	(40) 5 1/8" (130.2)	B2036
2"	(50) 6 11/16" (169.9)	B2013
2 1/2"	(65) 8 1/4" (209.5)	B2014
3"	(80) 9 13/16" (249.2)	B2048
3 1/2"	(90) 11 3/8" (288.9)	B2052
4"	(100) 12 15/16" (328.6)	B2056
5"	(125) 16 1/8" (409.6)	B2064
6"	(150) 19 1/4" (488.9)	B2112
8"	(200) 25 1/2" (647.7)	B2128

ISO PIPE

- Non-adhesive rubber tape
- Fuses to itself
- Water resistant
- Ideal Isolation Material
- Prevents galvanic reaction caused by dissimilar metal contact
- Temperature Range
-140°F (-60°C) to +395°F (+200°C)

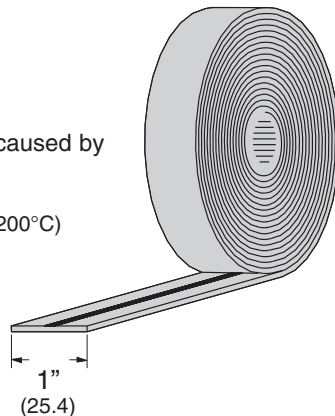

Part No.	Thickness		Ft./Roll	
	In.	mm	Ft.	m
ISO	.020	(0.5)	36	(11)

BVS Type - Vibra Strip™ for 1 5/8" (41.3) wide B-Line channel

- Fits securely in 1 5/8" wide channel
- Temperature range: -20°F to 212°F
- Ideal Isolation & Vibration Dampening Qualities
- 45 durometer hardness
- Material: Neoprene

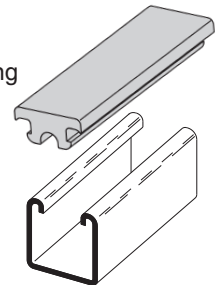

Part No.	Max. Load Lbs. per Lineal In.	Length	Std. Pkg.	Wt. Each
	Lbs. kg/25.4 mm			Lbs. kg
BVS-12	40 (18.1)	12" (304.8)	25	.46 (.21)
BVS-120	40 (18.1)	120" (3048.0)	25	4.60 (2.08)

Reference page 126 for general fitting and standard finish specifications.

Pipe Clamps

B2400 SERIES STANDARD PIPE STRAP

- Safety Factor of 5
- B2400-3/4 thru B2400-8 are UL listed
- Order hardware separately
- Other sizes available upon request
- Material: Sizes - 1/2" - 1 1/2", ASTM A1011 33,000 PSI min. yield;
2" - 12", ASTM A1018 33,000 PSI min. yield;
14"-Larger, ASTM A36
- Standard finish: ZN
- Ductile Iron Sizes Available
- Meets requirements of MSS SP-58 & SP-69 Type 26

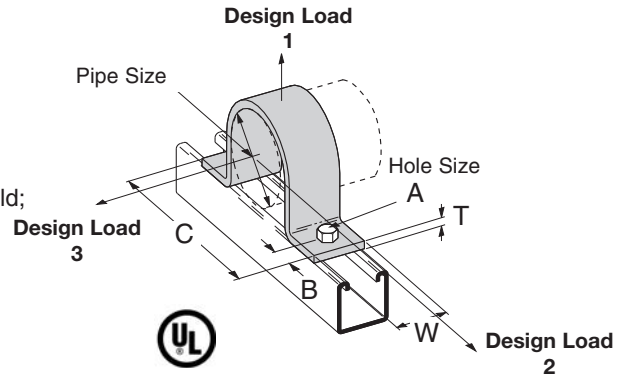

Part No.	Pipe Size		A		B		C		T		W	
B2400-1/2	1/2"	(15)	5/16"	(7.9)	7/16"	(11.1)	2 ¹³ / ₁₆ "	(71.4)	10 Ga.	(3.4)	1 ⁵ / ₈ "	(41.3)
B2400-3/4	3/4"	(20)	5/16"	(7.9)	7/16"	(11.1)	3"	(76.2)	10 Ga.	(3.4)	1 ⁵ / ₈ "	(41.3)
B2400-1	1"	(25)	5/16"	(7.9)	7/16"	(11.1)	3 ¹⁷ / ₃₂ "	(89.7)	10 Ga.	(3.4)	1 ⁵ / ₈ "	(41.3)
B2400-1 1/4	1 1/4"	(32)	5/16"	(7.9)	7/16"	(11.1)	3 ³ / ₄ "	(95.2)	10 Ga.	(3.4)	1 ⁵ / ₈ "	(41.3)
B2400-1 1/2	1 1/2"	(40)	5/16"	(7.9)	7/16"	(11.1)	4 ¹ / ₁₆ "	(103.2)	10 Ga.	(3.4)	1 ⁵ / ₈ "	(41.3)
B2400-2	2"	(50)	7/16"	(11.1)	11/16"	(17.4)	5 ²¹ / ₃₂ "	(143.6)	1/4"	(6.3)	1 ⁵ / ₈ "	(41.3)
B2400-2 1/2	2 1/2"	(65)	7/16"	(11.1)	11/16"	(17.4)	6 ⁵ / ₃₂ "	(156.3)	1/4"	(6.3)	1 ⁵ / ₈ "	(41.3)
B2400-3	3"	(80)	7/16"	(11.1)	11/16"	(17.4)	6 ²⁵ / ₃₂ "	(172.2)	1/4"	(6.3)	1 ⁵ / ₈ "	(41.3)
B2400-3 1/2	3 1/2"	(90)	7/16"	(11.1)	11/16"	(17.4)	7 ⁹ / ₃₂ "	(184.9)	1/4"	(6.3)	1 ⁵ / ₈ "	(41.3)
B2400-4	4"	(100)	9/16"	(14.3)	11/16"	(17.4)	7 ²⁵ / ₃₂ "	(197.6)	1/4"	(6.3)	1 ⁵ / ₈ "	(41.3)
B2400-5	5"	(125)	9/16"	(14.3)	11/16"	(17.4)	8 ⁷ / ₈ "	(225.4)	1/4"	(6.3)	1 ⁵ / ₈ "	(41.3)
B2400-6	6"	(150)	9/16"	(14.3)	11/16"	(17.4)	9 ¹⁵ / ₁₆ "	(252.4)	1/4"	(6.3)	1 ⁵ / ₈ "	(41.3)
B2400-8	8"	(200)	9/16"	(14.3)	11/16"	(17.4)	11 ³¹ / ₃₂ "	(304.0)	1/4"	(6.3)	1 ⁵ / ₈ "	(41.3)
B2400-10	10"	(250)	9/16"	(14.3)	11/16"	(17.4)	14"	(355.6)	1/4"	(6.3)	1 ⁵ / ₈ "	(41.3)
B2400-12	12"	(300)	9/16"	(14.3)	11/16"	(17.4)	16"	(406.4)	1/4"	(6.3)	1 ⁵ / ₈ "	(41.3)
B2400-14	14"	(350)	1 ⁵ / ₁₆ "	(23.8)	1 1/2"	(38.1)	20 ³ / ₄ "	(527.0)	3/8"	(9.5)	1 ³ / ₄ "	(44.4)
B2400-16	16"	(400)	1 ⁵ / ₁₆ "	(23.8)	1 1/2"	(38.1)	22 ³ / ₄ "	(577.8)	3/8"	(9.5)	1 ³ / ₄ "	(44.4)
B2400-18	18"	(460)	1 ⁵ / ₁₆ "	(23.8)	1 ³ / ₄ "	(44.4)	27"	(685.8)	1/2"	(12.7)	1 ³ / ₄ "	(44.4)
B2400-20	20"	(510)	1 ⁵ / ₁₆ "	(23.8)	1 ³ / ₄ "	(44.4)	29"	(736.6)	1/2"	(12.7)	1 ³ / ₄ "	(44.4)
B2400-24	24"	(610)	1 ⁵ / ₁₆ "	(23.8)	1 ³ / ₄ "	(44.4)	33"	(838.2)	1/2"	(12.7)	1 ³ / ₄ "	(44.4)

Part No.	Design Load 1		Design Load 2		Design Load 3		Wt./C	
	Lbs.	kN	Lbs.	kN	Lbs.	kN	Lbs.	kg
B2400-1/2	600	(2.67)	150	(.67)	105	(.47)	23	(10.4)
B2400-3/4	600	(2.67)	150	(.67)	105	(.47)	26	(11.8)
B2400-1	600	(2.67)	150	(.67)	120	(.53)	31	(14.0)
B2400-1 1/4	600	(2.67)	150	(.67)	120	(.53)	36	(16.3)
B2400-1 1/2	600	(2.67)	150	(.67)	120	(.53)	39	(17.7)
B2400-2	1200	(5.34)	480	(2.14)	180	(.80)	93	(42.2)
B2400-2 1/2	1200	(5.34)	480	(2.14)	180	(.80)	106	(48.1)
B2400-3	1200	(5.34)	480	(2.14)	300	(1.33)	132	(59.9)
B2400-3 1/2	1200	(5.34)	480	(2.14)	300	(1.33)	151	(68.5)
B2400-4	1500	(6.67)	600	(2.67)	450	(2.00)	160	(72.6)
B2400-5	1500	(6.67)	600	(2.67)	450	(2.00)	192	(87.1)
B2400-6	1500	(6.67)	600	(2.67)	450	(2.00)	219	(99.3)
B2400-8	2000	(8.90)	800	(3.56)	600	(2.67)	297	(134.7)
B2400-10	2000	(8.90)	800	(3.56)	600	(2.67)	465	(210.9)
B2400-12	2000	(8.90)	800	(3.56)	600	(2.67)	560	(254.0)
B2400-14	2000	(8.90)	800	(3.56)	600	(2.67)	761	(345.2)
B2400-16	2000	(8.90)	800	(3.56)	600	(2.67)	861	(390.5)
B2400-18	2000	(8.90)	800	(3.56)	600	(2.67)	1297	(588.3)
B2400-20	2000	(8.90)	800	(3.56)	600	(2.67)	1426	(646.8)
B2400-24	2000	(8.90)	800	(3.56)	600	(2.67)	1682	(762.9)

Reference page 126 for general fitting and standard finish specifications.

B437 SERIES TWO PIECE PIPE STRAP

- Clamp halves can turn allowing pipe to be fastened to channel at any direction
- Order hardware separately
- Standard finish: ZN

Part No.	Pipe Size		A		T		Wt./C	
							Lbs.	kg
B437-1/2	1/2"	(15)	5/16"	(7.9)	10 Ga.	(3.4)	22	(10.0)
B437-3/4	3/4"	(20)	5/16"	(7.9)	10 Ga.	(3.4)	26	(11.8)
B437-1	1"	(25)	5/16"	(7.9)	10 Ga.	(3.4)	30	(13.6)
B437-1 1/4	1 1/4"	(32)	5/16"	(7.9)	10 Ga.	(3.4)	35	(15.9)
B437-1 1/2	1 1/2"	(40)	5/16"	(7.9)	10 Ga.	(3.4)	38	(17.2)
B437-2	2"	(50)	7/16"	(11.1)	1/4"	(6.3)	91	(41.3)
B437-2 1/2	2 1/2"	(65)	7/16"	(11.1)	1/4"	(6.3)	104	(47.2)
B437-3	3"	(80)	7/16"	(11.1)	1/4"	(6.3)	130	(58.9)
B437-3 1/2	3 1/2"	(90)	7/16"	(11.1)	1/4"	(6.3)	149	(67.6)
B437-4	4"	(100)	9/16"	(11.1)	1/4"	(6.3)	158	(71.6)
B437-5	5"	(125)	9/16"	(11.1)	1/4"	(6.3)	190	(86.2)
B437-6	6"	(150)	9/16"	(11.1)	1/4"	(6.3)	217	(98.4)
B437-8	8"	(200)	9/16"	(11.1)	1/4"	(6.3)	295	(133.8)

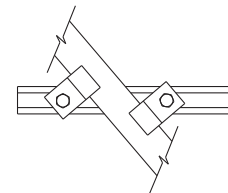
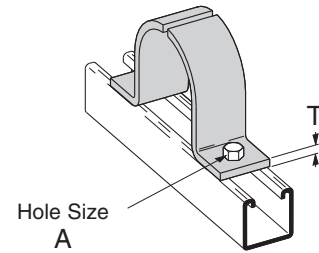

B2417 STRUT MOUNTED PIPE GUIDE

- Copper tubing sizes available - B2417CT Series
- Standard finish: ZN

Part No.	Pipe Size		Minimum Radial Clearance		Includes Clamp No.	Wt./C	
						Lbs.	kg
B2417-1/2	1/2"	(15)	1/16"	(1.6)	B2009	22	(10.0)
B2417-3/4	3/4"	(20)	1/16"	(1.6)	B2010	25	(11.3)
B2417-1	1"	(25)	3/32"	(2.3)	B2034	30	(13.6)
B2417-1 1/4	1 1/4"	(32)	3/32"	(2.3)	B2037	47	(21.8)
B2417-1 1/2	1 1/2"	(40)	3/32"	(2.3)	B2039	51	(23.1)
B2417-2	2"	(50)	1/8"	(3.2)	B2043	62	(28.1)
B2417-2 1/2	2 1/2"	(65)	1/8"	(3.2)	B2047	69	(31.3)
B2417-3	3"	(80)	5/32"	(3.9)	B2016	108	(49.0)
B2417-3 1/2	3 1/2"	(90)	5/32"	(3.9)	B2017	118	(53.5)
B2417-4	4"	(100)	5/32"	(3.9)	B2018	128	(58.0)

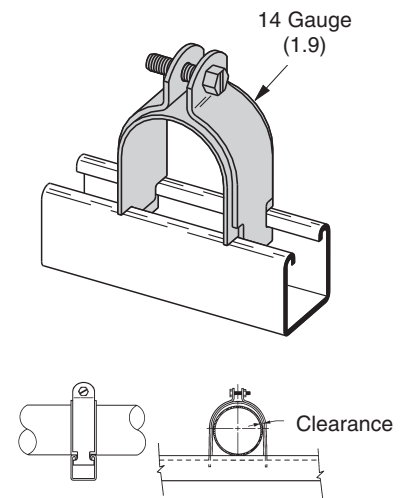

B2070 THRU B2080 PARALLEL PIPE CLAMP

- Safety Factor of 2
- Designed to support pipe or rigid conduit
- Includes:
 - 1 pr. Pipe Clamps
 - 1 pc. Stand Off Plate
 - 1 pc. Slotted Hex Head Machine Screws
 - 1 pc. Square Nut
- Standard finish: ZN

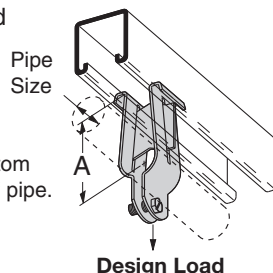

Part No.	Pipe Size		A		Material Thickness	Design Load		Wt./C	
						Lbs.	kN	Lbs.	kg
B2070	3/8"	(10)	1 11/16"	(42.9)	16 Ga. (1.5)	300	(1.33)	24	(10.9)
B2071	1/2"	(15)	1 3/4"	(44.4)	16 Ga. (1.5)	300	(1.33)	26	(11.8)
B2072	3/4"	(20)	1 7/8"	(47.6)	14 Ga. (1.9)	300	(1.33)	30	(13.6)
B2073	1"	(25)	2"	(50.8)	14 Ga. (1.9)	400	(1.78)	33	(14.9)
B2074	1 1/4"	(32)	2 3/16"	(55.6)	14 Ga. (1.9)	400	(1.78)	36	(16.3)
B2075	1 1/2"	(40)	2 5/16"	(58.7)	12 Ga. (2.6)	500	(2.22)	50	(22.7)
B2076	2"	(50)	2 9/16"	(65.1)	12 Ga. (2.6)	500	(2.22)	55	(24.9)
B2077	2 1/2"	(65)	2 7/8"	(73.0)	12 Ga. (2.6)	500	(2.22)	60	(27.2)
B2078	3"	(80)	3 3/16"	(80.9)	12 Ga. (2.6)	500	(2.22)	66	(29.9)
B2079	3 1/2"	(90)	3 7/16"	(87.3)	11 Ga. (3.0)	500	(2.22)	85	(38.5)
B2080	4"	(100)	3 5/8"	(92.1)	11 Ga. (3.0)	500	(2.22)	95	(43.1)

A dimension, from bottom of channel to center of pipe.

Pipe Size

Design Load

Reference page 126 for general fitting and standard finish specifications.

Pipe Clamps

B670 SERIES PARALLEL PIPE CLAMP

- Designed to support pipe or rigid conduit parallel to the edge of a beam or angle iron
- Hardware included
- Material: Malleable Iron
- Standard finish: HDG

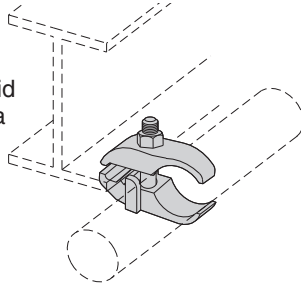

Part Number	Pipe or Conduit Size		Wt./C	
			Lbs.	kg
B670-3/8	3/8"	(10)	32	(14.5)
B670-1/2	1/2"	(15)	58	(26.3)
B670-3/4	3/4"	(20)	64	(29.0)
B670-1	1"	(25)	70	(31.7)
B670-1 1/4	1 1/4"	(32)	77	(34.9)
B670-1 1/2	1 1/2"	(40)	93	(42.2)
B670-2	2"	(50)	105	(47.6)
B670-2 1/2	2 1/2"	(65)	143	(64.8)
B670-3	3"	(80)	164	(74.4)
B670-3 1/2	3 1/2"	(90)	190	(86.2)
B670-4	4"	(100)	205	(93.0)

B671 SERIES EDGE PIPE CLAMP

- Designed to support pipe or rigid conduit perpendicular to the edge of a beam or angle iron
- Hardware included
- Material: Malleable Iron
- Standard finish: HDG

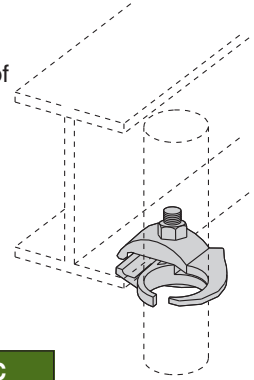

Part Number	Pipe or Conduit Size		Wt./C	
			Lbs.	kg
B671-1/2	1/2"	(15)	67	(30.4)
B671-3/4	3/4"	(20)	71	(32.2)
B671-1	1"	(25)	85	(38.5)
B671-1 1/4	1 1/4"	(32)	91	(41.3)
B671-1 1/2	1 1/2"	(40)	115	(52.1)
B671-2	2"	(50)	135	(61.2)
B671-2 1/2	2 1/2"	(65)	183	(83.0)
B671-3	3"	(80)	230	(104.3)

B422 SERIES RIGHT ANGLE CLAMP

- Safety Factor of 5
- Material: 7 Gauge (4.5)
- Standard finishes: ZN, SS4

Part No.	Conduit Size		A	Design Load Vertical Pull		Wt./C		
				Lbs.	kg	Lbs.	kg	
B422-1/2	1/2"	(15)	2 3/8"	(60.3)	250	(1.11)	38	(17.2)
B422-3/4	3/4"	(20)	2 3/8"	(60.3)	300	(1.33)	39	(17.7)
B422-1	1"	(25)	2 7/8"	(73.0)	400	(1.78)	48	(21.8)
B422-1 1/4	1 1/4"	(32)	2 7/8"	(73.0)	400	(1.78)	50	(22.7)
B422-1 1/2	1 1/2"	(40)	3 1/4"	(82.5)	500	(2.22)	59	(26.7)
B422-2	2"	(50)	3 11/16"	(93.7)	600	(2.67)	75	(34.0)
B422-2 1/2	2 1/2"	(65)	4 1/4"	(107.9)	700	(3.11)	98	(44.4)
B422-3	3"	(80)	4 7/8"	(123.8)	800	(3.56)	111	(50.3)
B422-3 1/2	3 1/2"	(90)	5 7/16"	(138.1)	900	(4.00)	123	(55.8)
B422-4	4"	(100)	6"	(152.4)	1000	(4.45)	135	(61.2)

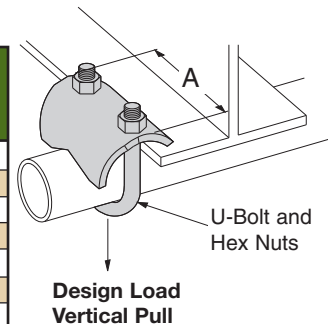

B3367S RETAINING STRAP

- Available in 'L' lengths of 6" (152.4), 8" (203.2), 9" (228.6), 10" (254.0), 12" (304.8), 14" (355.6), 16" (406.4), 18" (457.2)
- Material: Steel
- Standard finishes: ZN, PLN

Part No.	Hole Dia. D	For Use With	Wt./C**	
			Lbs.	kg
B3367S-1-L	7/16"	(30.1)	B422-1/2 & 3/4	33.4 (5.8)
B3367S-2-L	9/16"	(30.1)	B422-1, 1 1/4 & 1 1/2	12.8 (15.1)

** Wt./C based on 6" (152.4) length. For each additional inch in strap length add the following to the Wt./C.
 For B3367S-1 add 5.7 Lbs (2.6 kg)
 For B3367S-2 add 2.2 Lbs (1.0 kg)

Note: Use B3367-3/8 retaining strap (page 102) for B422-2 thru 4

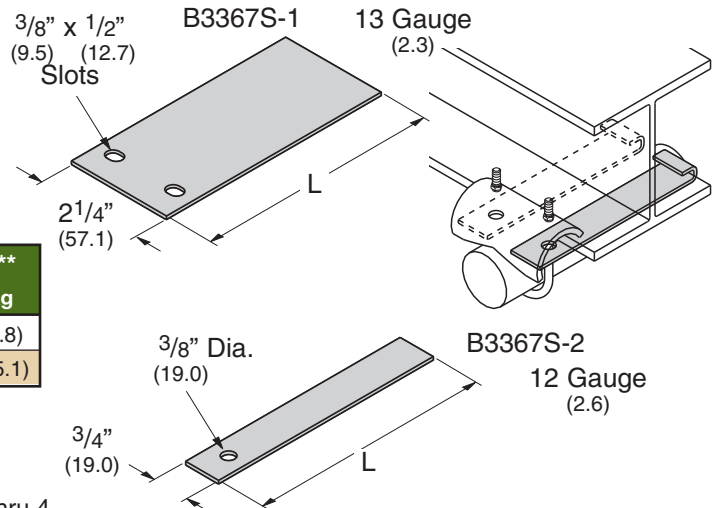

Reference page 126 for general fitting and standard finish specifications.

B2301 SERIES ONE HOLE EMT STRAP

- Standard finish: ZN

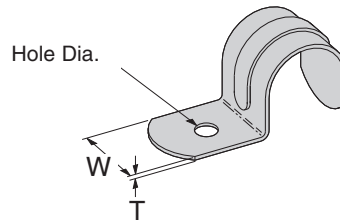

Part No.	Conduit Size		T		W		Hole Dia.		Wt./C	
									Lbs.	kg
B2301-1/2	1/2"	(15)	.050	(1.3)	3/4"	(19.0)	9/32"	(7.1)	2.4	(1.1)
B2301-3/4	3/4"	(20)	.050	(1.3)	7/8"	(22.2)	9/32"	(7.1)	4.2	(1.9)
B2301-1	1"	(25)	.050	(1.3)	1"	(25.4)	9/32"	(7.1)	8.3	(3.7)
B2301-1 1/4	1 1/4"	(32)	.065	(1.6)	1 1/4"	(31.7)	9/32"	(7.1)	11.0	(5.0)
B2301-1 1/2	1 1/2"	(40)	.090	(2.3)	1"	(25.4)	11/32"	(8.7)	14.8	(6.7)
B2301-2	2"	(50)	.090	(2.3)	1 1/4"	(31.7)	13/32"	(10.3)	21.6	(9.8)

B2302 SERIES ONE HOLE RIGID CONDUIT/PIPE STRAP

- Standard finish: ZN

Part No.	Conduit/Pipe Size		T		W		Hole Dia.		Wt./C	
									Lbs.	kg
B2302-1/4	1/4"	(6)	.045	(1.1)	5/8"	(15.9)	13/64"	(5.1)	1.4	(.6)
B2302-3/8	3/8"	(10)	.050	(1.3)	3/4"	(19.0)	9/32"	(7.1)	2.4	(1.1)
B2302-1/2	1/2"	(15)	.050	(1.3)	7/8"	(22.2)	9/32"	(7.1)	3.3	(1.5)
B2302-3/4	3/4"	(20)	.050	(1.3)	7/8"	(22.2)	9/32"	(7.1)	3.8	(1.7)
B2302-1	1"	(25)	.065	(1.6)	1"	(25.4)	9/32"	(7.1)	7.2	(3.2)
B2302-1 1/4	1 1/4"	(32)	.065	(1.6)	1 1/4"	(31.7)	21/64"	(8.3)	11.0	(5.0)
B2302-1 1/2	1 1/2"	(40)	11 Ga.	(3.0)	1"	(25.4)	.380	(9.6)	19.2	(8.7)
B2302-2	2"	(50)	11 Ga.	(3.0)	1 1/4"	(31.7)	.389	(9.9)	28.8	(13.0)
B2302-2 1/2	2 1/2"	(65)	7 Ga.	(4.5)	1 1/4"	(31.7)	.665	(16.9)	55.2	(25.0)
B2302-3	3"	(80)	7 Ga.	(4.5)	1 1/4"	(31.7)	.650	(16.5)	68.0	(30.8)
B2302-3 1/2	3 1/2"	(90)	1/4"	(6.3)	1 1/4"	(31.7)	.622	(15.8)	96.0	(43.5)
B2302-4	4"	(100)	1/4"	(6.3)	1 1/4"	(31.7)	.630	(16.0)	108.0	(49.0)

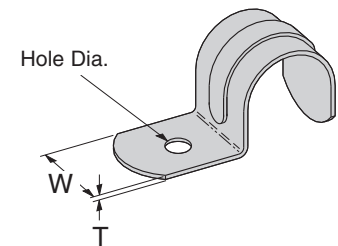

B2084 THRU B2091 ONE HOLE O.D. TUBING CLAMP

- Material: 14 Gauge (1.9) ASTM A1011 33,000 PSI min. yield
- Standard finish: ZN

Part No.	O.D. Size		A		Wt./C	
					Lbs.	kg
B2084	1/4"	(6.3)	7/8"	(22.2)	4.0	(1.8)
B2085	5/16"	(7.9)	29/32"	(23.0)	4.2	(1.9)
B2086	3/8"	(9.5)	31/32"	(24.6)	5.2	(2.3)
B2087	1/2"	(12.7)	1 1/16"	(25.9)	5.8	(2.6)
B2088	5/8"	(15.9)	1 3/32"	(27.8)	7.1	(3.2)
B2089	3/4"	(19.0)	1 5/32"	(29.1)	7.7	(3.5)
B2090	7/8"	(22.2)	1 7/32"	(30.7)	8.7	(3.9)
B2091	1"	(25.4)	1 9/32"	(32.2)	10.0	(4.5)

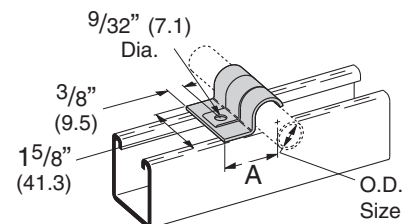

Reference page 126 for general fitting and standard finish specifications.

Pipe Clamps

BL1400 SERIES CONDUIT HANGER

- Safety Factor of 3
- Unless noted all sizes fit both rigid (R) and thinwall (EMT) conduit
- Hardware included
- Standard finishes: ZN, SS4

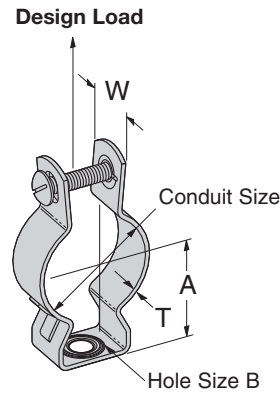

Part No	Conduit Size		A		B		T		W		Design Load		Wt./C	
											Lbs.	kN	Lbs.	kg
BL1400	1/2"	(15)	29/32"	(23.0)	9/32"	(7.1)	16 Ga.	(1.5)	3/4"	(19.0)	590	(2.62)	6	(2.7)
BL1410	3/4"	(20)	31/32"	(24.6)	9/32"	(7.1)	16 Ga.	(1.5)	3/4"	(19.0)	590	(2.62)	7	(3.2)
BL1420	1"	(25)	1 1/4"	(31.7)	9/32"	(7.1)	16 Ga.	(1.5)	3/4"	(19.0)	590	(2.62)	8	(3.6)
BL1425	1 1/4" EMT	(32)	1 1/4"	(31.7)	9/32"	(7.1)	18 Ga.	(1.2)	7/8"	(22.2)	590	(2.62)	10	(4.5)
BL1430	1 1/4" R, 1 1/2" EMT	(32)	1 13/32"	(35.7)	9/32"	(8.7)	18 Ga.	(1.2)	7/8"	(22.2)	590	(2.62)	10	(4.5)
BL1440	1 1/2" R	(40)	1 5/8"	(41.3)	11/32"	(8.7)	16 Ga.	(1.5)	1"	(25.4)	755	(3.36)	17	(7.7)
BL1450	2"	(50)	2 1/16"	(47.6)	11/32"	(8.7)	16 Ga.	(1.5)	1 1/4"	(31.7)	755	(3.36)	25	(11.3)
BL1460	2 1/2"	(65)	2 1/16"	(52.4)	11/32"	(8.7)	16 Ga.	(1.5)	1 1/4"	(31.7)	755	(3.36)	26	(11.8)
BL1470	3"	(80)	2 1/2"	(63.5)	11/32"	(8.7)	16 Ga.	(1.5)	1 1/4"	(31.7)	820	(3.65)	33	(14.9)
BL1480	3 1/2"	(90)	2 3/4"	(69.8)	11/32"	(8.7)	16 Ga.	(1.5)	1 1/4"	(31.7)	850	(3.78)	36	(16.3)
BL1490	4"	(100)	3 1/2"	(88.9)	11/32"	(8.7)	16 Ga.	(1.5)	1 1/4"	(31.7)	1410	(6.27)	40	(18.1)

B3373 SERIES RISER CLAMP

- Safety Factor of 3.5
- B3373-3/4 thru B3373-8 are UL listed
- Includes Hex Head Cap Screws and Hex Nuts
- Standard finishes: ZN, PLN

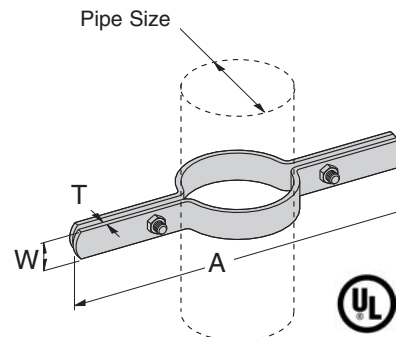

Part No.	Pipe Size		A		Design Load		Wt./C	
					Lbs.	kN	Lbs.	kg
B3373-1/2	1/2"	(15)	9"	(228.6)	255	(1.13)	101	(45.9)
B3373-3/4	3/4"	(20)	9 1/4"	(234.9)	255	(1.13)	105	(47.7)
B3373-1	1"	(25)	9 9/16"	(242.9)	255	(1.13)	109	(49.4)
B3373-1 1/4	1 1/4"	(32)	10"	(254.0)	255	(1.13)	112	(50.9)
B3373-1 1/2	1 1/2"	(32)	10 1/4"	(260.3)	255	(1.13)	113	(51.1)
B3373-2	2"	(40)	10 3/4"	(273.0)	255	(1.13)	165	(75.0)
B3373-2 1/2	2 1/2"	(50)	11 1/4"	(285.7)	390	(1.73)	180	(81.6)
B3373-3	3"	(65)	11 15/16"	(303.2)	530	(2.36)	195	(88.4)
B3373-3 1/2	3 1/2"	(80)	12 3/8"	(314.3)	670	(2.98)	217	(98.5)
B3373-4	4"	(90)	12 7/8"	(327.0)	810	(3.60)	228	(103.5)
B3373-5	5"	(100)	14"	(355.6)	1160	(5.16)	480	(217.7)
B3373-6	6"	(100)	15 3/16"	(385.8)	1570	(6.98)	526	(238.6)
B3373-8	8"	(100)	17 3/4"	(450.8)	2500	(11.12)	957	(434.1)

Reference page 126 for general fitting and standard finish specifications.

B3690 SERIES ADJUSTABLE J HANGER

- Safety Factor of 5
- Material:
 - 12 Ga. (2.6) ASTM A1011 33,000 PSI min. yield
 - 11 Ga. (3.0) ASTM A1011 HSLA Gr. 50 Class 1
 - 7 Ga. (4.5) ASTM A1011 33,000 PSI min. yield and 1/4" (6.3) ASTM A1018 33,000 PSI min. yield
- Standard finish: ZN

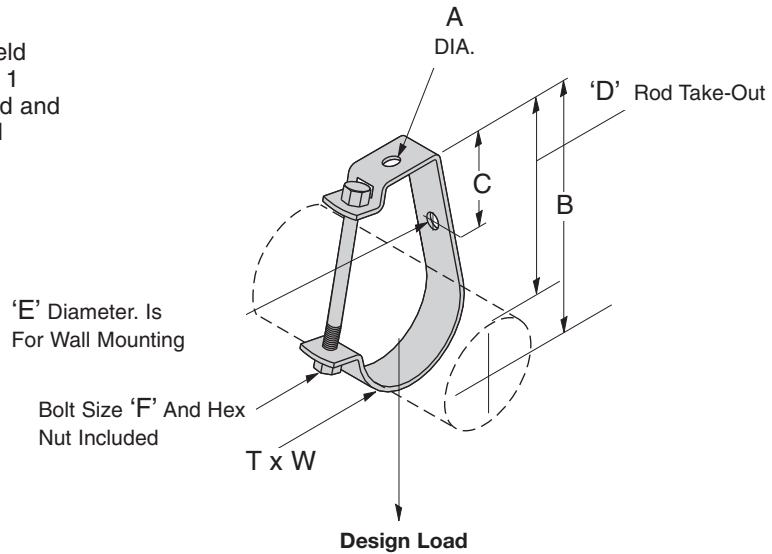
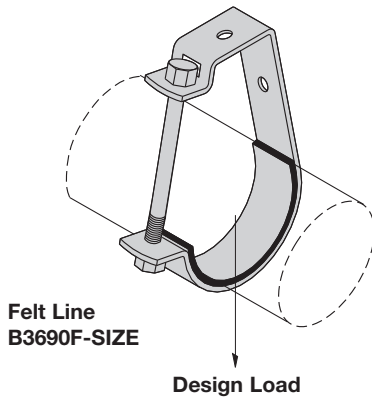

Part No.	Pipe or Conduit Size		A		B		C		D		E		F
B3690-1/2	1/2"	(15)	13/32"	(10.3)	23/32"	(53.2)	1"	(25.4)	1 11/16"	(42.5)	13/32"	(10.3)	1/4"-20 x 2 1/4"
B3690-3/4	3/4"	(20)	13/32"	(10.3)	2 11/32"	(59.5)	1"	(25.4)	1 13/16"	(46.2)	13/32"	(10.3)	1/4"-20 x 2 1/2"
B3690-1	1"	(25)	13/32"	(10.3)	2 19/32"	(65.9)	1"	(25.4)	1 15/16"	(49.2)	13/32"	(10.3)	1/4"-20 x 2 3/4"
B3690-1 1/4	1 1/4"	(32)	13/32"	(10.3)	2 13/16"	(71.4)	1"	(25.4)	2"	(50.4)	13/32"	(10.3)	1/4"-20 x 3"
B3690-1 1/2	1 1/2"	(40)	13/32"	(10.3)	3 1/16"	(77.8)	1"	(25.4)	2 1/8"	(53.7)	13/32"	(10.3)	1/4"-20 x 3 1/4"
B3690-2	2"	(50)	13/32"	(10.3)	3 1/2"	(88.9)	1"	(25.4)	2 5/16"	(58.7)	13/32"	(10.3)	1/4"-20 x 3 1/2"
B3690-2 1/2	2 1/2"	(65)	9/16"	(14.3)	4 7/16"	(112.7)	1"	(25.4)	3"	(76.2)	9/16"	(14.3)	3/8"-16 x 4 1/2"
B3690-3	3"	(80)	9/16"	(14.3)	4 7/8"	(123.8)	1"	(25.4)	3 1/8"	(79.4)	9/16"	(14.3)	3/8"-16 x 5"
B3690-3 1/2	3 1/2"	(90)	9/16"	(14.3)	5 3/16"	(131.8)	1"	(25.4)	3 3/16"	(81.0)	9/16"	(14.3)	3/8"-16 x 5 1/2"
B3690-4	4"	(100)	1 1/16"	(17.5)	6 1/8"	(155.6)	1 1/4"	(31.8)	3 7/8"	(98.4)	9/16"	(14.3)	3/8"-16 x 6 1/2"
B3690-5	5"	(125)	1 1/16"	(17.5)	6 3/4"	(171.4)	1 1/2"	(38.1)	4"	(100.8)	9/16"	(14.3)	3/8"-16 x 7 1/2"
B3690-6	6"	(150)	1 3/16"	(20.6)	7 3/4"	(196.8)	1 3/16"	(30.2)	4 7/16"	(112.7)	9/16"	(14.3)	3/8"-16 x 8 1/2"
B3690-8	8"	(200)	1 3/16"	(20.6)	9 1/4"	(235.0)	1"	(25.4)	4 15/16"	(125.4)	9/16"	(14.3)	3/8"-16 x 10 1/2"

Part No.	T	W	Design Load		Wt./C	
			Lbs.	kN	Lbs.	kg
B3690-1/2	12 Ga. (2.6)	3/4" (19.0)	400	(1.78)	20	(9.1)
B3690-3/4	12 Ga. (2.6)	3/4" (19.0)	400	(1.78)	23	(10.4)
B3690-1	12 Ga. (2.6)	3/4" (19.0)	400	(1.78)	24	(10.9)
B3690-1 1/4	12 Ga. (2.6)	3/4" (19.0)	400	(1.78)	27	(12.2)
B3690-1 1/2	12 Ga. (2.6)	3/4" (19.0)	400	(1.78)	29	(13.1)
B3690-2	12 Ga. (2.6)	3/4" (19.0)	400	(1.78)	32	(14.5)
B3690-2 1/2	11 Ga. (3.0)	1 1/4" (31.7)	800	(3.56)	71	(32.2)
B3690-3	11 Ga. (3.0)	1 1/4" (31.7)	800	(3.56)	77	(34.9)
B3690-3 1/2	11 Ga. (3.0)	1 1/4" (31.7)	800	(3.56)	84	(38.1)
B3690-4	7 Ga. (4.5)	1 1/4" (31.7)	800	(3.56)	139	(63.0)
B3690-5	7 Ga. (4.5)	1 1/4" (31.7)	800	(3.56)	166	(75.3)
B3690-6	1/4" (6.3)	1 1/4" (31.7)	1000	(4.45)	226	(102.5)
B3690-8	1/4" (6.3)	1 1/2" (38.1)	1200	(5.34)	332	(150.6)

Reference page 126 for general fitting and standard finish specifications.

Pipe Hangers

B386 SERIES SUSPENSION ROD PIPE STRAP

- Safety Factor of 3
- Includes Hex Head Cap Screws and Hex Nuts
- Standard finishes: ZN, GRN

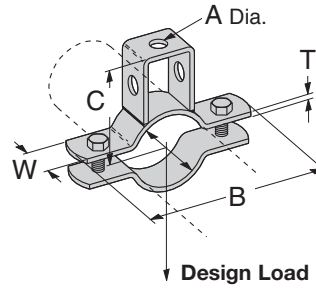

Part No.	Pipe Size		A		B		C		T		W		Design Load		Wt./C	
	in	(mm)	in	(mm)	in	(mm)	in	(mm)	in	(mm)	in	(mm)	Lbs.	kN	Lbs.	kg
B386-3/4	3/4"	(20)	7/16"	(11.1)	3 ⁵ / ₁₆ "	(84.1)	2 ³ / ₁₆ "	(55.6)	1/8"	(3.2)	1"	(25.4)	730	(3.25)	46	(20.8)
B386-1	1"	(25)	7/16"	(11.1)	3 ³ / ₄ "	(95.2)	2 ⁵ / ₁₆ "	(58.7)	1/8"	(3.2)	1"	(25.4)	730	(3.25)	51	(23.1)
B386-1 ¹ / ₄	1 ¹ / ₄ "	(32)	7/16"	(11.1)	4"	(101.6)	2 ¹⁷ / ₃₂ "	(64.3)	1/8"	(3.2)	1"	(25.4)	730	(3.25)	52	(23.6)
B386-1 ¹ / ₂	1 ¹ / ₂ "	(40)	7/16"	(11.1)	4 ⁵ / ₁₆ "	(109.5)	2 ¹¹ / ₁₆ "	(68.3)	1/8"	(3.2)	1"	(25.4)	730	(3.25)	54	(24.5)
B386-2	2"	(50)	7/16"	(11.1)	5 ¹ / ₂ "	(139.7)	3 ⁵ / ₁₆ "	(84.1)	1/4"	(6.3)	1"	(25.4)	730	(3.25)	134	(60.8)
B386-2 ¹ / ₂	2 ¹ / ₂ "	(65)	9/16"	(14.3)	6 ³ / ₈ "	(161.9)	3 ¹ / ₂ "	(88.9)	1/4"	(6.3)	1"	(25.4)	1350	(6.00)	157	(71.2)
B386-3	3"	(80)	9/16"	(14.3)	7"	(177.8)	3 ⁷ / ₈ "	(98.4)	1/4"	(6.3)	1"	(25.4)	1350	(6.00)	168	(76.2)
B386-3 ¹ / ₂	3 ¹ / ₂ "	(90)	9/16"	(14.3)	7 ⁹ / ₁₆ "	(192.1)	4 ¹ / ₈ "	(104.8)	1/4"	(6.3)	1"	(25.4)	1350	(6.00)	197	(89.3)
B386-4	4"	(100)	9/16"	(14.3)	8 ⁵ / ₈ "	(219.1)	4 ³ / ₈ "	(111.1)	1/4"	(6.3)	1 ¹ / ₄ "	(31.7)	1350	(6.00)	270	(122.4)
B386-5	5"	(125)	1 ¹ / ₁₆ "	(17.4)	9 ³ / ₄ "	(247.6)	5 ³ / ₁₆ "	(131.8)	1/4"	(6.3)	1 ¹ / ₄ "	(31.7)	2160	(9.61)	308	(139.7)
B386-6	6"	(150)	1 ¹ / ₁₆ "	(17.4)	11 ⁵ / ₈ "	(295.3)	6 ¹ / ₁₆ "	(154.0)	3/8"	(9.5)	1 ¹ / ₂ "	(38.1)	2160	(9.61)	609	(276.4)
B386-8	8"	(200)	1 ³ / ₁₆ "	(20.6)	13 ⁷ / ₈ "	(352.4)	7 ¹ / ₈ "	(181.0)	3/8"	(9.5)	1 ¹ / ₂ "	(38.1)	3230	(14.37)	713	(323.4)

B394 SERIES PIPE STRAP

- Safety Factor of 3
- Includes:
 - 1 Pair Pipe Clamps with Hex Head Cap Screws and Hex Nuts
 - 1 Hanger Strap
- Standard finishes: ZN

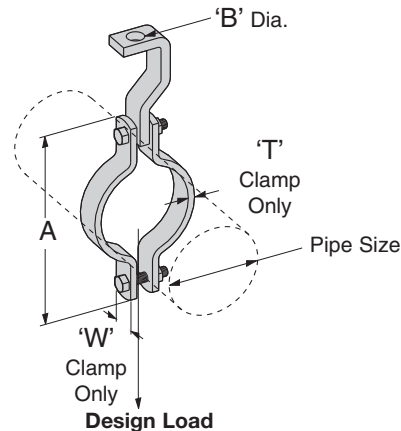

Part No.	Pipe Size		A		B		T		W		Design Load		Wt./C	
	in	(mm)	in	(mm)	in	(mm)	in	(mm)	in	(mm)	Lbs.	kN	Lbs.	kg
B394-3/4	3/4"	(20)	3 ⁵ / ₁₆ "	(84.1)	7/16"	(11.1)	1/8"	(3.2)	1"	(25.4)	500	(2.22)	71	(32.2)
B394-1	1"	(25)	3 ³ / ₄ "	(95.2)	7/16"	(11.1)	1/8"	(3.2)	1"	(25.4)	500	(2.22)	76	(34.5)
B394-1 ¹ / ₄	1 ¹ / ₄ "	(32)	4"	(101.6)	7/16"	(11.1)	1/8"	(3.2)	1"	(25.4)	500	(2.22)	77	(34.9)
B394-1 ¹ / ₂	1 ¹ / ₂ "	(40)	4 ⁵ / ₁₆ "	(109.5)	7/16"	(11.1)	1/8"	(3.2)	1"	(25.4)	800	(3.56)	79	(35.8)
B394-2	2"	(50)	5 ¹ / ₂ "	(139.7)	7/16"	(11.1)	1/4"	(6.3)	1"	(25.4)	1040	(4.62)	166	(75.3)
B394-2 ¹ / ₂	2 ¹ / ₂ "	(65)	6 ³ / ₈ "	(161.9)	9/16"	(14.3)	1/4"	(6.3)	1"	(25.4)	1040	(4.62)	179	(81.2)
B394-3	3"	(80)	7"	(177.8)	9/16"	(14.3)	1/4"	(6.3)	1"	(25.4)	1040	(4.62)	190	(86.2)
B394-3 ¹ / ₂	3 ¹ / ₂ "	(90)	7 ⁹ / ₁₆ "	(192.1)	9/16"	(14.3)	1/4"	(6.3)	1"	(25.4)	1040	(4.62)	203	(92.1)
B394-4	4"	(100)	8 ⁵ / ₈ "	(219.1)	1 ¹ / ₁₆ "	(17.4)	1/4"	(6.3)	1 ¹ / ₄ "	(31.7)	1040	(4.62)	320	(145.1)
B394-5	5"	(125)	9 ³ / ₄ "	(247.6)	1 ¹ / ₁₆ "	(17.4)	1/4"	(6.3)	1 ¹ / ₄ "	(31.7)	1040	(4.62)	353	(160.1)
B394-6	6"	(150)	11 ⁵ / ₈ "	(295.3)	1 ³ / ₁₆ "	(20.6)	3/8"	(9.5)	1 ¹ / ₂ "	(38.1)	1615	(7.18)	637	(288.9)
B394-8	8"	(200)	13 ⁷ / ₈ "	(352.4)	1 ³ / ₁₆ "	(20.6)	3/8"	(9.5)	1 ¹ / ₂ "	(38.1)	1615	(7.18)	837	(379.6)

Reference page 126 for general fitting and standard finish specifications.

B591 SERIES PIPE BRACKET SADDLE AND CLAMP

- Safety Factor of 3
- Inside brace not required on B591-2 and B591-2 1/2
- Includes:
 - 1 pc. Saddle bottom
 - 1 pc. Saddle top (clamp)
 - 2 pcs. Hex Head Cap Screws
 - 2 pcs. Hex Nuts
- Standard finish: ZN

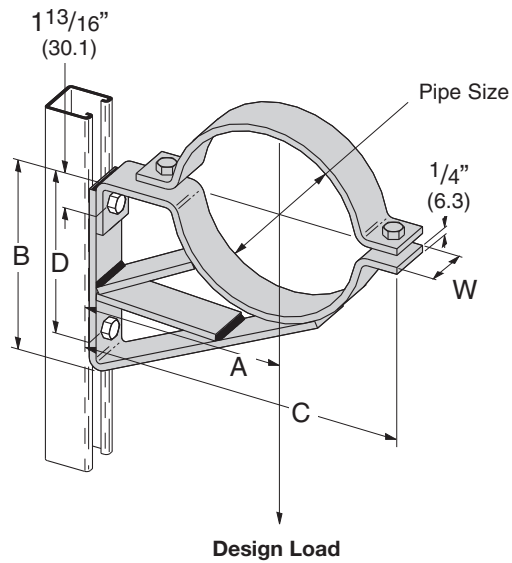

Part No.	Pipe Size		A		B		C		D		W		Design Load		Wt./C	
	in	(mm)	in	(mm)	in	(mm)	in	(mm)	in	(mm)	in	(mm)	Lbs.	kN	Lbs.	kg
B591-2	2"	(50)	4 1/2"	(114.3)	4 1/2"	(114.3)	7 3/16"	(182.6)	3 1/16"	(77.8)	1 5/8"	(41.3)	1235	(5.53)	290	(131.5)
B591-2 1/2	2 1/2"	(65)	5"	(127.0)	5"	(127.0)	7 15/16"	(201.6)	3 9/16"	(90.5)	1 5/8"	(41.3)	1180	(5.29)	330	(149.7)
B591-3	3"	(80)	5 1/2"	(139.7)	5 3/4"	(146.0)	8 3/4"	(222.2)	3 13/16"	(96.8)	1 5/8"	(41.3)	1125	(5.04)	439	(199.1)
B591-3 1/2	3 1/2"	(90)	6"	(152.4)	6 3/4"	(171.4)	9 1/2"	(241.3)	4 9/16"	(115.9)	1 5/8"	(41.3)	1070	(4.79)	490	(222.2)
B591-4	4"	(100)	6 1/2"	(165.1)	6 3/4"	(171.4)	10 1/4"	(260.3)	6 1/16"	(128.6)	1 5/8"	(41.3)	1015	(4.55)	545	(247.2)
B591-5	5"	(125)	7 1/2"	(190.5)	8"	(203.2)	12 1/8"	(308.0)	6 1/16"	(154.0)	1 5/8"	(41.3)	960	(4.30)	666	(302.1)
B591-6	6"	(150)	8"	(203.2)	8 3/4"	(222.2)	13 3/16"	(335.0)	6 13/16"	(173.0)	1 5/8"	(41.3)	905	(4.05)	724	(328.4)
B591-8	8"	(200)	9"	(228.6)	10 1/2"	(266.7)	15 9/16"	(395.3)	8 9/16"	(217.5)	2"	(50.8)	850	(3.81)	1087	(493.0)

Reference page 126 for general fitting and standard finish specifications.

Pipe Block

B356

PIPE BLOCK-2" (50) TO 8" (200) PIPE

- Required hardware not included:
 - 1 pc. $\frac{3}{8}$ "-16 x 1" Hex Head Cap Screw
 - 1 pc. $\frac{3}{8}$ "-16 Channel Nut
- Material: $\frac{1}{4}$ " (6.3) thick $1\frac{5}{8}$ " (41.3) wide
- ASTM A1018 33,000 PSI min. yield
- Standard finish: ZN
- Wt./C 42 Lbs. (19.0 kg) Per Pair

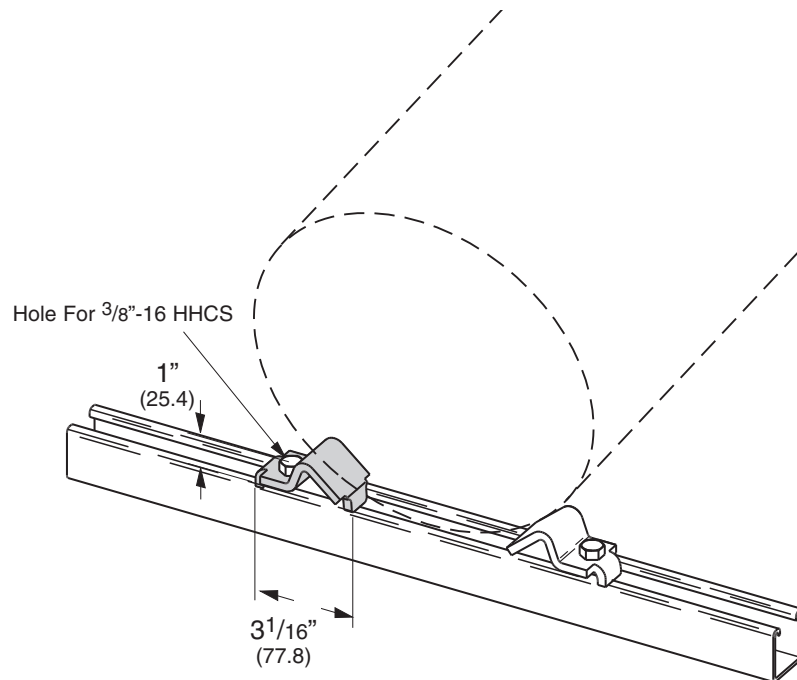

Reference page 126 for general fitting and standard finish specifications.

B218 PIPE ROLLERS-1/2" (15) TO 8" (200) PIPE

- Design Load 500 Lbs. (2.22 kN)
- Safety Factor of 5
- When used with B3160 thru B3165 Saddles
(See Pipe Hanger Catalog)
- Malleable Iron Rollers
- Sold in pairs
- Required hardware not included:
2 pcs. 1/2"-13 x 1 1/4" Hex Head Cap Screws
2 pcs. 1/2"-13 Channel Nuts
- Standard finish: ZN
- Wt./C 256 Lbs. (116.1 kg) Per Pair

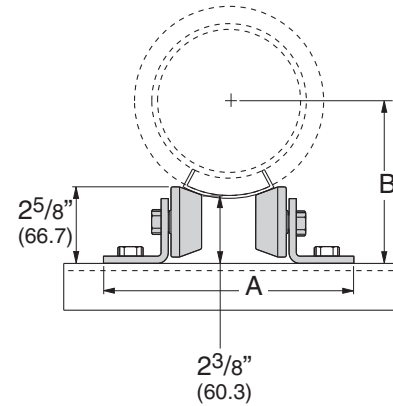
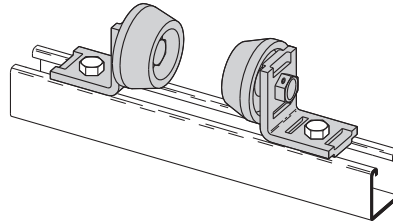

REFERENCE CHART - A DIMENSION

Pipe Size	Insulation Thickness in. (mm)													
	0" (0.0)		1" (25.4)		1 1/2" (38.1)		2" (50.8)		2 1/2" (63.5)		3" (76.2)		4" (101.6)	
1/2" (15)	7 1/4" (184.1)	(184.1)	-	-	-	-	-	-	-	-	-	-	-	-
3/4" (20)	7 1/4" (184.1)	(184.1)	7 1/4" (184.1)	(184.1)	7 5/8" (193.7)	(193.7)	8" (203.2)	(203.2)	-	-	-	-	-	-
1" (25)	7 1/4" (184.1)	(184.1)	7 1/4" (184.1)	(184.1)	7 5/8" (193.7)	(193.7)	8 1/4" (209.5)	(209.5)	-	-	-	-	-	-
1 1/4" (32)	7 1/4" (184.1)	(184.1)	7 1/4" (184.1)	(184.1)	8" (203.2)	(203.2)	8 1/4" (209.5)	(209.5)	-	-	-	-	-	-
1 1/2" (40)	7 1/4" (184.1)	(184.1)	7 5/8" (193.7)	(193.7)	8" (203.2)	(203.2)	8 1/2" (215.9)	(215.9)	9" (228.6)	(228.6)	-	-	-	-
2" (50)	7 1/4" (184.1)	(184.1)	7 5/8" (193.7)	(193.7)	8 1/2" (215.9)	(215.9)	8 1/2" (215.9)	(215.9)	9" (228.6)	(228.6)	-	-	-	-
2 1/2" (65)	7 1/4" (184.1)	(184.1)	8" (203.2)	(203.2)	8 1/2" (215.9)	(215.9)	9" (228.6)	(228.6)	10" (254.0)	(254.0)	-	-	-	-
3" (80)	7 1/4" (184.1)	(184.1)	8 1/2" (215.9)	(215.9)	9" (228.6)	(228.6)	9" (228.6)	(228.6)	10" (254.0)	(254.0)	10" (254.0)	(254.0)	-	-
3 1/2" (90)	7 1/4" (184.1)	(184.1)	8 1/2" (215.9)	(215.9)	9" (228.6)	(228.6)	10" (254.0)	(254.0)	10" (254.0)	(254.0)	10" (254.0)	(254.0)	-	-
4" (100)	7 5/8" (193.7)	(193.7)	9" (228.6)	(228.6)	9" (228.6)	(228.6)	10" (254.0)	(254.0)	10" (254.0)	(254.0)	11" (279.4)	(279.4)	-	-
5" (125)	8 1/2" (215.9)	(215.9)	9" (228.6)	(228.6)	10" (254.0)	(254.0)	10" (254.0)	(254.0)	11" (279.4)	(279.4)	11" (279.4)	(279.4)	12" (304.8)	(304.8)
6" (150)	9" (228.6)	(228.6)	10" (254.0)	(254.0)	10" (254.0)	(254.0)	11" (279.4)	(279.4)	11" (279.4)	(279.4)	11" (279.4)	(279.4)	12" (304.8)	(304.8)
8" (200)	10" (254.0)	(254.0)	11" (279.4)	(279.4)	11" (279.4)	(279.4)	11" (279.4)	(279.4)	12" (304.8)	(304.8)	-	-	-	-

REFERENCE CHART - B DIMENSION

Pipe Size	Insulation Thickness in. (mm)													
	0" (0.0)		1" (25.4)		1 1/2" (38.1)		2" (50.8)		2 1/2" (63.5)		3" (76.2)		4" (101.6)	
1/2" (15)	2 11/16" (68.3)	(68.3)	-	-	-	-	-	-	-	-	-	-	-	-
3/4" (20)	2 13/16" (71.4)	(71.4)	3 7/8" (98.4)	(98.4)	4 3/8" (111.1)	(111.1)	4 7/8" (123.8)	(123.8)	-	-	-	-	-	-
1" (25)	2 15/16" (74.6)	(74.6)	4 3/16" (106.4)	(106.4)	4 11/16" (119.1)	(119.1)	5 1/16" (128.6)	(128.6)	-	-	-	-	-	-
1 1/4" (32)	3 1/8" (79.4)	(79.4)	4 3/16" (106.4)	(106.4)	4 5/8" (117.5)	(117.5)	5 1/8" (130.2)	(130.2)	-	-	-	-	-	-
1 1/2" (40)	3 1/4" (82.5)	(82.5)	4 3/8" (111.1)	(111.1)	4 7/8" (123.8)	(123.8)	5 5/16" (134.9)	(134.9)	5 3/4" (146.0)	(146.0)	-	-	-	-
2" (50)	3 9/16" (90.5)	(90.5)	4 11/16" (119.1)	(119.1)	5 1/16" (128.6)	(128.6)	5 5/8" (142.9)	(142.9)	6 1/16" (154.0)	(154.0)	-	-	-	-
2 1/2" (65)	3 13/16" (96.8)	(96.8)	4 7/8" (123.8)	(123.8)	5 5/16" (134.9)	(134.9)	6" (152.4)	(152.4)	6 3/8" (161.9)	(161.9)	-	-	-	-
3" (80)	4 1/8" (104.8)	(104.8)	5 1/16" (128.6)	(128.6)	5 9/16" (141.3)	(141.3)	6 1/8" (155.6)	(155.6)	6 7/16" (163.5)	(163.5)	7" (177.8)	(177.8)	-	-
3 1/2" (90)	4 3/8" (111.1)	(111.1)	5 5/16" (134.9)	(134.9)	5 13/16" (147.6)	(147.6)	6 1/4" (158.7)	(158.7)	6 11/16" (169.9)	(169.9)	7 1/4" (184.1)	(184.1)	-	-
4" (100)	4 5/8" (117.5)	(117.5)	5 9/16" (141.3)	(141.3)	6 1/16" (154.0)	(154.0)	6 7/16" (163.5)	(163.5)	6 15/16" (176.2)	(176.2)	7 3/8" (187.3)	(187.3)	-	-
5" (125)	5" (127.0)	(127.0)	6 1/16" (154.0)	(154.0)	6 7/16" (163.5)	(163.5)	7" (177.8)	(177.8)	7 3/8" (187.3)	(187.3)	7 7/8" (200.0)	(200.0)	8 13/16" (223.8)	(223.8)
6" (150)	5 1/2" (139.7)	(139.7)	6 7/16" (163.5)	(163.5)	6 15/16" (176.2)	(176.2)	7 3/8" (187.3)	(187.3)	7 15/16" (201.6)	(201.6)	8 1/2" (215.9)	(215.9)	9 1/2" (241.3)	(241.3)
8" (200)	6 15/16" (160.3)	(160.3)	7 3/8" (187.3)	(187.3)	7 15/16" (201.6)	(201.6)	8 7/16" (214.3)	(214.3)	8 15/16" (227.0)	(227.0)	-	-	-	-

Reference page 126 for general fitting and standard finish specifications.

Pipe Rollers

B219

PIPE ROLLER SERIES - 3/4" (20) TO 12" (300) PIPE

- Design Load 750 Lbs. (3.33 kN)
- Safety Factor of 5
- Requires field assembly
- When used with B3160 thru B3165 Saddles
(See Pipe Hanger Catalog)
- Malleable Iron Rollers
- Sold in pairs
- Required hardware not included:
2 pcs. 1/2"-13 x 1 1/4" Hex Head Cap Screws
2 pcs. 1/2"-13 Channel Nuts
- Reference sizing chart on page 135
- Standard finish: ZN

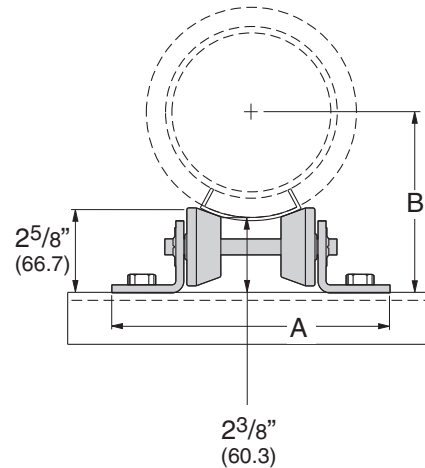
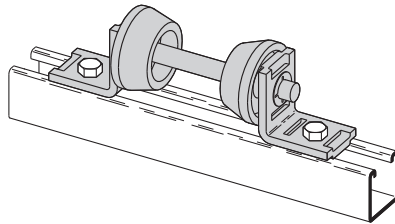

REFERENCE CHART - A DIMENSION

Part No.	A		Wt./C PR	
			Lbs.	kg
B219	7 1/4"	(184.1)	253	(114.7)
B219-1	8"	(203.2)	258	(117.0)
B219-2	9"	(228.6)	263	(119.3)
B219-3	10"	(254.0)	269	(122.0)
B219-4	10 7/8"	(276.2)	274	(124.8)
B219-5	11 5/8"	(295.3)	279	(126.5)

REFERENCE CHART - B DIMENSION

Pipe Size		Insulation Thickness in. (mm)													
		0" (0.0)		1" (25.4)		1 1/2" (38.1)		2" (50.8)		2 1/2" (63.5)		3" (76.2)		4" (101.6)	
1/2"	(15)	2 11/16"	(68.3)	-	-	-	-	-	-	-	-	-	-	-	-
3/4"	(20)	2 13/16"	(71.4)	3 7/8"	(98.4)	4 1/2"	(114.3)	4 7/8"	(123.8)	-	-	-	-	-	-
1"	(25)	2 15/16"	(74.6)	4 3/16"	(106.4)	4 5/8"	(117.5)	5 1/16"	(128.6)	-	-	-	-	-	-
1 1/4"	(32)	3 1/8"	(79.4)	4 3/16"	(106.4)	4 5/8"	(117.5)	5 1/8"	(130.2)	-	-	-	-	-	-
1 1/2"	(40)	3 1/4"	(82.5)	4 7/16"	(112.7)	4 7/8"	(123.8)	5 1/4"	(133.3)	5 3/4"	(146.0)	-	-	-	-
2"	(50)	3 9/16"	(90.5)	4 5/8"	(117.5)	5 3/16"	(131.8)	5 1/2"	(139.7)	6 1/16"	(154.0)	-	-	-	-
2 1/2"	(65)	3 3/4"	(95.2)	4 7/8"	(123.8)	5 1/4"	(133.3)	6"	(152.4)	6 3/8"	(161.9)	-	-	-	-
3"	(80)	4 1/8"	(104.8)	5 1/8"	(130.2)	5 9/16"	(141.3)	6 1/16"	(154.0)	6 7/16"	(163.5)	6 15/16"	(176.2)	-	-
3 1/2"	(90)	4 1/4"	(107.9)	5 1/4"	(133.3)	5 13/16"	(147.6)	6 1/4"	(158.7)	6 11/16"	(169.9)	7 1/16"	(179.4)	-	-
4"	(100)	4 9/16"	(115.9)	5 1/2"	(139.7)	6 1/16"	(154.0)	6 7/16"	(163.5)	6 15/16"	(176.2)	7 3/8"	(187.3)	-	-
5"	(125)	5 1/16"	(128.6)	6 1/16"	(154.0)	6 7/16"	(163.5)	7"	(177.8)	7 3/8"	(187.3)	7 7/8"	(200.0)	8 15/16"	(227.0)
6"	(150)	5 7/16"	(138.1)	6 7/16"	(163.5)	6 15/16"	(176.2)	7 3/8"	(187.3)	7 7/8"	(200.0)	8 15/16"	(211.1)	9 9/16"	(242.9)
8"	(200)	6 3/8"	(161.9)	7 7/16"	(188.9)	7 15/16"	(201.6)	8 3/8"	(212.7)	9"	(228.6)	-	-	-	-
10"	(250)	7 5/16"	(185.7)	8 3/16"	(208.0)	-	-	-	-	-	-	-	-	-	-
12"	(300)	8 1/4"	(209.5)	-	-	-	-	-	-	-	-	-	-	-	-

Reference B219 sizing chart on page 149

Reference page 126 for general fitting and standard finish specifications.

B219 SIZING CHART

Pipe Size		Insulation Thickness in. (mm)						
		0" (0.0)	1" (25.4)	1 1/2" (38.1)	2" (50.8)	2 1/2" (63.5)	3" (76.2)	4" (101.6)
1/2"	(15)	B219	–	–	–	–	–	–
3/4"	(20)	B219	B219	B219	B219-1	–	–	–
1"	(25)	B219	B219	B219-1	B219-1	–	–	–
1 1/4"	(32)	B219	B219	B219-1	B219-1	–	–	–
1 1/2"	(40)	B219	B219	B219-1	B219-2	B219-2	–	–
2"	(50)	B219	B219-1	B219-1	B219-2	B219-2	–	–
2 1/2"	(65)	B219	B219-1	B219-2	B219-2	B219-3	–	–
3"	(80)	B219	B219-1	B219-2	B219-2	B219-3	B219-3	–
3 1/2"	(90)	B219-1	B219-2	B219-2	B219-3	B219-3	B219-4	–
4"	(100)	B219-1	B219-2	B219-2	B219-3	B219-3	B219-4	–
5"	(125)	B219-1	B219-2	B219-3	B219-3	B219-4	B219-4	B219-5
6"	(150)	B219-2	B219-3	B219-3	B219-4	B219-4	B219-5	B219-5
8"	(200)	B219-3	B219-4	B219-4	B219-5	B219-5	–	–
10"	(250)	B219-4	B219-5	–	–	–	–	–
12"	(300)	B219-5	–	–	–	–	–	–

Reference page 126 for general fitting and standard finish specifications.

Pipe Rollers

B379

PIPE ROLLERS-6" (150) TO 18" (450) PIPE

- Design Load 1500 Lbs. (6.67 kN)
- Safety Factor of 5
- Requires field assembly
- When used with B3160 thru B3165 Saddles
(See Pipe Hanger Catalog)
- Malleable Iron Rollers
- Sold in pairs
- Required hardware not included:
2 pcs. 1/2"-13 x 1 1/4" Hex Head Cap Screws
2 pcs. 1/2"-13 Channel Nuts
- Standard finish: ZN
- Wt./C 889 Lbs. (403.2 kg)

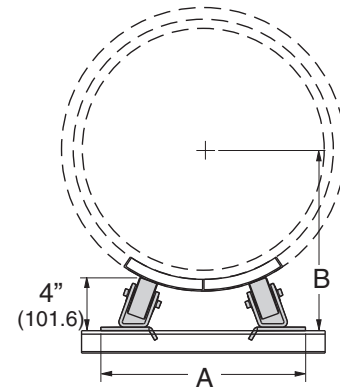
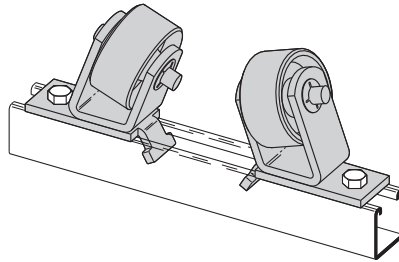

REFERENCE CHART - A DIMENSION

Pipe Size	Insulation Thickness in. (mm)													
	0" (0.0)		1" (25.4)		1 1/2" (38.1)		2" (50.8)		2 1/2" (63.5)		3" (76.2)		4" (101.6)	
6" (150)	9 9/16"	(242.9)	10 3/16"	(258.8)	10 5/8"	(269.9)	11"	(279.4)	11 3/8"	(288.9)	11 3/4"	(298.4)	12 1/2"	(317.5)
8" (200)	10 1/4"	(260.3)	11 1/16"	(281.0)	11 3/8"	(288.9)	11 3/4"	(298.4)	12 3/16"	(309.6)	12 1/2"	(317.5)	13 1/4"	(336.5)
10" (250)	11"	(279.4)	11 3/4"	(298.4)	12 1/8"	(308.0)	12 1/2"	(317.5)	12 13/16"	(325.4)	13 1/8"	(333.4)	13 7/8"	(352.4)
12" (300)	11 11/16"	(296.9)	12 9/16"	(319.1)	12 7/8"	(327.0)	13 1/4"	(336.5)	13 9/16"	(344.5)	13 7/8"	(352.4)	14 5/8"	(371.5)
14" (350)	12 1/16"	(306.4)	12 7/8"	(327.0)	13 3/16"	(335.0)	13 9/16"	(344.5)	13 7/8"	(352.4)	14 1/4"	(361.9)	14 7/8"	(377.8)
16" (400)	12 3/4"	(323.8)	13 1/2"	(342.9)	13 7/8"	(352.4)	14 13/16"	(360.4)	14 1/2"	(368.3)	14 7/8"	(377.8)	15 1/2"	(393.7)
18" (450)	13 1/2"	(342.9)	14 1/4"	(361.9)	14 5/8"	(371.5)	15"	(381.0)	15 5/16"	(388.9)	15 5/8"	(396.9)	16 5/16"	(414.3)

REFERENCE CHART - B DIMENSION

Pipe Size	Insulation Thickness in. (mm)													
	0" (0.0)		1" (25.4)		1 1/2" (38.1)		2" (50.8)		2 1/2" (63.5)		3" (76.2)		4" (101.6)	
6" (150)	6 7/8"	(174.6)	7 7/8"	(200.0)	8 3/8"	(212.7)	8 7/8"	(225.4)	9 3/8"	(238.1)	9 7/8"	(250.8)	10 15/16"	(277.8)
8" (200)	7 13/16"	(198.4)	8 7/8"	(225.4)	9 3/8"	(238.1)	9 7/8"	(250.8)	10 7/16"	(265.1)	10 15/16"	(277.8)	11 7/8"	(301.6)
10" (250)	8 13/16"	(223.8)	9 7/8"	(250.8)	10 7/16"	(265.1)	10 15/16"	(277.8)	11 3/8"	(288.9)	11 7/8"	(301.6)	12 13/16"	(325.4)
12" (300)	9 3/4"	(247.6)	10 15/16"	(277.8)	11 3/8"	(288.9)	11 7/8"	(301.6)	12 5/16"	(312.7)	12 13/16"	(325.4)	13 3/4"	(349.2)
14" (350)	10 5/16"	(261.9)	11 3/8"	(288.9)	11 7/8"	(301.6)	12 5/16"	(312.7)	12 13/16"	(325.4)	13 1/4"	(336.5)	14 1/4"	(361.9)
16" (400)	11 5/16"	(287.3)	12 5/16"	(312.7)	12 13/16"	(325.4)	13 1/4"	(336.5)	13 3/4"	(349.2)	14 1/4"	(361.9)	15 1/8"	(384.2)
18" (450)	12 1/4"	(311.1)	13 1/4"	(336.5)	13 3/4"	(349.2)	14 3/16"	(360.4)	14 11/16"	(373.1)	15 1/8"	(384.2)	16 1/16"	(408.0)

Reference page 126 for general fitting and standard finish specifications.

B479

PIPE ROLLERS-16" (400) TO 30" (750) PIPE

- Design Load 2000 Lbs. (8.89 kN)
- Safety Factor of 5
- Requires field assembly
- When used with B3160 thru B3165 Saddles
(See Pipe Hanger Catalog)
- Malleable Iron Rollers
- Sold in pieces
- Required hardware not included:
4 pcs. 1/2"-13 x 1 1/4" Hex Head Cap Screws
4 pcs. 1/2"-13 Channel Nuts
- Standard finish: ZN
- Wt./C 889 Lbs. (403.2 kg)

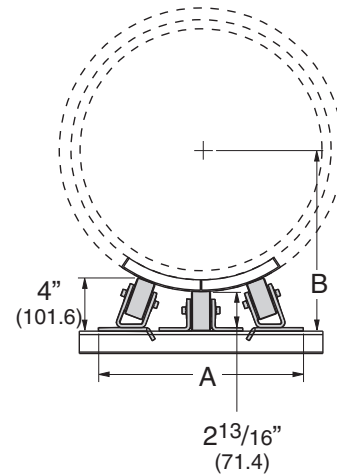
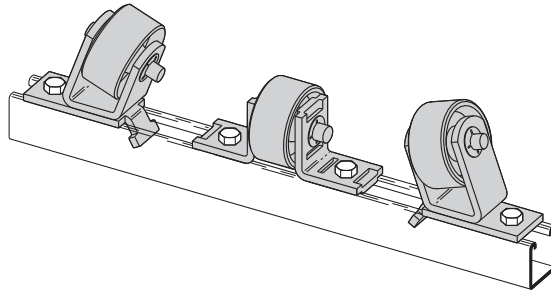

REFERENCE CHART - A DIMENSION

Pipe Size	Insulation Thickness in. (mm)													
	0" (0.0)		1" (25.4)		1 1/2" (38.1)		2" (50.8)		2 1/2" (63.5)		3" (76.2)		4" (101.6)	
16" (400)	15 3/16"	(385.8)	15 5/8"	(396.9)	15 7/8"	(403.2)	16"	(406.4)	16 1/4"	(412.7)	16 1/2"	(419.1)	17"	(431.8)
18" (450)	15 1/2"	(393.7)	16"	(406.4)	16 3/16"	(411.2)	16 3/8"	(415.9)	16 9/16"	(420.7)	16 3/4"	(425.4)	17 3/16"	(436.6)
20" (500)	16"	(406.4)	16 3/8"	(415.9)	16 9/16"	(420.7)	16 7/8"	(428.6)	16 15/16"	(430.2)	17 3/16"	(436.6)	17 1/2"	(444.5)
24" (600)	16 13/16"	(427.0)	17 5/16"	(439.7)	17 1/2"	(444.5)	17 1/2"	(444.5)	17 11/16"	(449.3)	17 7/8"	(454.0)	18 1/8"	(460.4)
30" (750)	17 13/16"	(452.4)	18 1/4"	(463.5)	18 3/8"	(466.7)	18 9/16"	(471.5)	18 7/8"	(476.2)	18 7/8"	(479.4)	19 1/4"	(488.9)

REFERENCE CHART - B DIMENSION

Pipe Size	Insulation Thickness in. (mm)													
	0" (0.0)		1" (25.4)		1 1/2" (38.1)		2" (50.8)		2 1/2" (63.5)		3" (76.2)		4" (101.6)	
16" (400)	10 13/16"	(274.6)	11 15/16"	(303.2)	12 3/8"	(314.3)	12 15/16"	(328.6)	13 3/8"	(339.7)	13 15/16"	(354.0)	14 15/16"	(379.4)
18" (450)	11 7/8"	(301.6)	12 15/16"	(328.6)	13 7/16"	(341.3)	13 15/16"	(354.0)	14 7/16"	(366.7)	14 15/16"	(379.4)	15 15/16"	(404.8)
20" (500)	12 3/16"	(325.4)	13 15/16"	(354.0)	14 7/16"	(366.7)	14 7/8"	(377.8)	15 7/16"	(392.1)	15 7/8"	(403.2)	16 15/16"	(430.2)
24" (600)	14 13/16"	(376.2)	15 7/8"	(403.2)	16 3/8"	(415.9)	16 7/8"	(428.6)	17 3/8"	(441.3)	17 7/8"	(454.0)	18 7/8"	(479.4)
30" (750)	17 13/16"	(452.4)	18 7/8"	(479.4)	19 3/8"	(492.1)	19 7/8"	(504.8)	20 3/8"	(517.5)	20 5/16"	(531.8)	21 15/16"	(557.2)

Reference page 126 for general fitting and standard finish specifications.