

FLEXTRAY® Wall Support Methods

Shelf Brackets

- Heavy-duty support bracket
- For use with 6" (150mm) to 24" (600mm) wide trays
- Built-in tab for hold down
- Accepts 1/4" through 1 1/2" conduit sizes for additional support options
- Optional hardware sold separately
- Finishes __: **GLV**, HDG, SS6

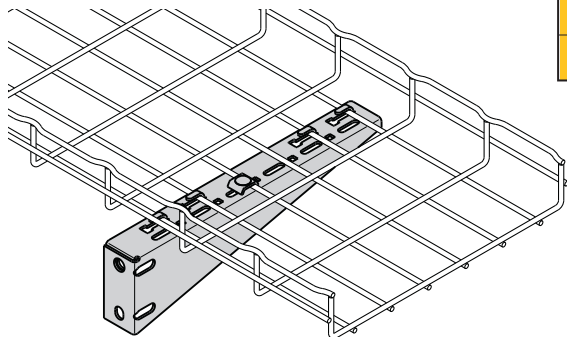

Part Number	Use With Tray Width	Qty./Box	Wt./Box	
			lbs.	kg
FTB6CS __	6" (150mm)	1	0.5	0.22
FTB8CS __	8" (200mm)	1	0.6	0.27
FTB12CS __	12" (300mm)	1	1.2	0.54
FTB16CS __	16" (400mm)	1	1.7	0.77
FTB18CS __	18" (450mm)	1	1.9	0.86
FTB20CS __	20" (500mm)	1	2.6	1.18
FTB24CS __	24" (600mm)	1	3.2	1.45



L Brackets

- Installs tray to wall cleanly
- Built-in tab for hold down (not available in stainless steel)
- For use with 4" (100mm) to 24" (600mm) wide trays
- Use with pedestal clamp in raised floor applications
- Hardware sold separately
- Finishes __: **EG**, HD, BLE, SPC

Part Number	Use With Tray Width	Qty./Box	Wt./Box	
			lbs.	kg
4 L BRKT __	4" (150mm)	1	0.6	0.27
8 L BRKT __	6" (150mm) & 8" (200mm)	1	0.8	0.36
12 L BRKT __	12" (300mm)	1	1.3	0.59
16 L BRKT __	16" (400mm)	1	1.4	0.63
20 L BRKT __	20" (500mm)	1	2.0	0.91
24 L BRKT __	24" (600mm)	1	2.3	1.04

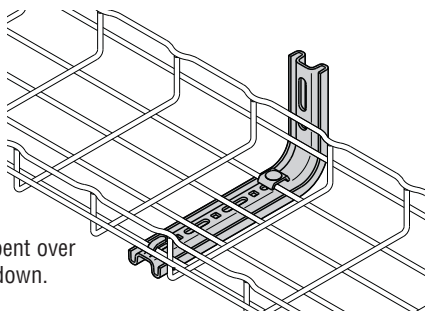

Tab can be bent over for hold down.



See page 5 for finish information