

FLEXTRAY® Raised Floor System

Pedestal Clamps

- Clamps to existing raised-access floor stanchion
- Use L BRKT (see page 24) or full pedestal kit to support trays under the raised access floor (sold separately)
- For tray widths 2" (50mm) to 20" (500mm)
- *Pedestal Clamp Kit includes two (2) pedestal clamps, 28" (711mm) profile section, bolts & nuts
- Kits include hardware
- Finishes __: **EG**

| Part Number | Description | Qty./Box | Wt./Box | |
|-------------------------|--------------------|----------|---------|------|
| | | | lbs. | kg |
| PEDESTAL CLAMP__ | Pedestal Clamp | 1 | 0.6 | 0.27 |
| PEDESTAL KIT__ | Pedestal Clamp Kit | 1* | 3.3 | 1.49 |

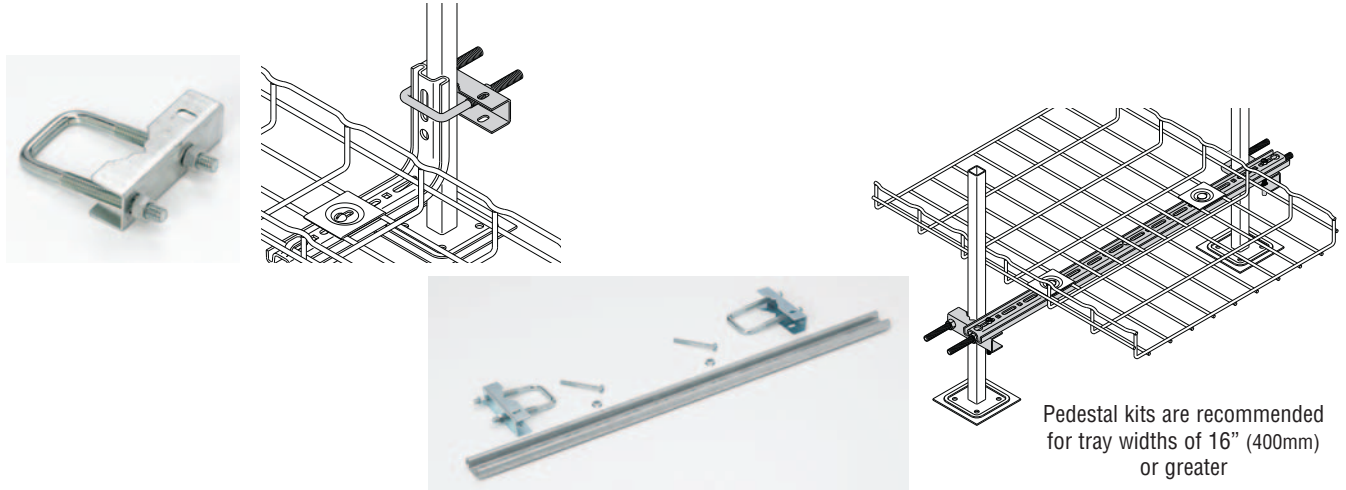

Floor Pans

- Raises trays off the floor
- For use with 4" (100mm) to 20" (500mm) wide trays
- Use toolless clip to hold down tray to support
- Multiple pans may be needed for wider trays
- Finishes __: **GS**, BLE, SPC

| Part Number | Description | Qty./Box | Wt./Box | |
|----------------------|---------------------------|----------|---------|------|
| | | | lbs. | kg |
| FLOOR PAN 4__ | 4" (100mm) High Floor Pan | 1 | 2.6 | 1.18 |
| FLOOR PAN 6__ | 6" (150mm) High Floor Pan | 1 | 3.3 | 1.49 |

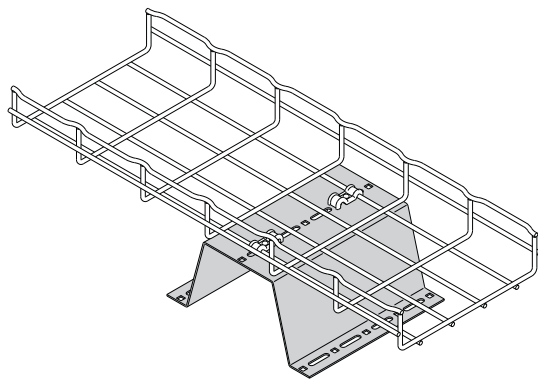

FLOOR PAN 4



See page 5 for finish information